



# Development of an Integrated Approach to Reliability Management and Operation

In One Volume  
Marisa Ocon B.Tech  
January 2001

Submitted for the Degree of  
Master in Science



Submitted to : Galway Mayo Institute of Technology, Ireland  
Research carried out at : Galway Mayo Institute of Technology, Ireland  
Research Supervisor : Dr. Thomas Roche

# Acknowledgements

There is a long list of people that I sincerely need to thank for a valuable and beautiful two-year experience in Ireland. For what I've learned, what I've lived and what I've received from all of them.

First of all, thank you Tom, my supervisor, for always having faith in my work, for the support, the guidance and the criticism. In the good days, and in the bad ones, I have always appreciated your advice in both professional and personal matters. Thank you for the opportunity that you gave me and for everything I have learned.

Second, my working colleague and friend, Padraig. We have spent a lot of time together, day after day for the last two years, and what can I say? It has been great. You've helped me a lot in every sense. So thanks for that help, and for the chitchats, and for the laughs and all the rest. I hope you make it to Spain sometime. Go Raibh mile maith agat.

To everybody in the R&D department in ThermoKing. For a wonderful professional and personal experience. For always making me feel integrated and at ease, for being such a nice people, and for everything I've learned. Special thanks to John Gough and Gareth Bennet that were my mentors and guidance during that period.

Thanks to the staff in GMIT for their support, especially everybody in the engineering department. To all the research crowd: Valerie, Radu, Anders, Elena, Ovidio, Camilia, Vlad... all the best in your futures.

To Anita, Uli and Ciara, the constants in my life. Good friends, good support and good fun. Thanks Anita for everything. You have been amazing to me.

To Trina, Christoph, and most specially Patricia and Aitana. They were a wonderful family, and since they left, life has not been full of those little moments of happiness that we used to have.

To my friends at home that even from the distance have helped me through some of the bad moments and have become such a special part of my life.

To Nic for making my life a bit more complicated, a bit more intense and always a better place to be in.

And finally, the most difficult thanks to express. My family: my father, my mother, my brother and my sister. I have no words to thank you for all that you have given me or for telling you how important you are to me. Gracias.

# Prologue

The research described in this thesis has been developed as a part of the Reliability and Field Data Management for Multi-component Products (REFIDAM) Project. This project was founded under the Applied Research Grants Scheme administered by Enterprise Ireland. The project was a partnership between Galway-Mayo Institute of Technology and Thermo King Europe. The project aimed to develop a system in order to manage the information required for reliability assessment and improvement of multi-component products, by establishing information flows within the company and information exchange with fleet users.

# Table of Contents

<b>Chapter 1 Introduction</b> .....	<b>1</b>
1.1 Thesis Motivation.....	1
1.2 Objectives of the Thesis.....	2
1.3 Approach to Work.....	2
1.4 Thesis Structure.....	3
<b>Chapter 2 Reliability Program Plan</b> .....	<b>5</b>
2.1 Introduction.....	5
2.2 Definition of Reliability.....	6
2.3 The Process of Reliability.....	7
2.4 Program Management and Control.....	9
2.5 Program Initiatives.....	13
2.6 Supplier Reliability and Quality Assurance.....	14
2.7 Design for Reliability.....	17
2.8 Statistical Methods and Models in Reliability.....	22
2.9 Reliability Testing.....	28
2.10 Reliability in Manufacture.....	32
2.11 Maintenance Strategies.....	33
2.12 Failure Analysis, Root Cause and Corrective Action.....	35
2.13 Structure for the Reliability Program.....	36
2.14 Summary.....	39
<b>Chapter 3 Information Systems for the Reliability Program</b> .....	<b>40</b>
3.1 Introduction.....	40
3.2 Requirements for the Reliability management Information system.....	40
3.3 Benchmarking of Reliability Software Tools.....	43
3.4 Product Data Management Systems.....	50
3.5 Summary.....	56

<b>Chapter 4 Case Study: Prototype of a Reliability Management System for a Specific Application.....</b>	<b>57</b>
4.1 Introduction.....	57
4.2 Company Overview and Requirements.....	58
4.3 Overall Structure of the RFDM System.....	59
4.3 Design Specification and Functional Specification of the RFDM Prototype.....	63
4.4 Summary.....	74
<b>Chapter 5 Prototyped Reliability and Field Data Management System (RFDM).....</b>	<b>75</b>
5.1 Introduction.....	75
5.2 RFDM Overview.....	76
5.3 Performing Field Data Analysis.....	85
5.4 Failure Report and Corrective Action System.....	92
5.4 Critical Item Reliability.....	100
5.5 FMEA Analysis.....	103
5.6 Suppliers and Parts Qualification Process.....	105
5.7 Reliability Predictions, Specifications and Requirements.....	111
5.8 Summary.....	115
<b>Chapter 6. Conclusions and Further Work.....</b>	<b>116</b>
6.1 Thesis Summary.....	116
6.2 Results and Conclusions.....	118
6.3 Further Development.....	122

**References**

**Appendices**

# List of Figures

## Chapter 1

Figure 1.1 Structure of the thesis.

## Chapter 2

Figure 2.1 The Process of Reliability.

Figure 2.2 FTA of a Cooling system.

Figure 2.3 Reliability models: Series and Parallel System.

Figure 2.4 Structure of the Reliability Program Plan.

## Chapter 3

Figure 3.1 Product Data Management in the Organization.

## Chapter 4

Figure 4.1 Reliability Management System: Overall Structure.

Figure 4.2 Support Information Management Structure.

Figure 4.3 Level 0 Information Structure.

Figure 4.4 Level 1 Reliability Processes.

Figure 4.5 Process 1.1 Failure Report and Corrective Action System.

Figure 4.6 Process 1.2 Critical Item Reliability.

Figure 4.7 Process 1.3 FMEA documentation.

Figure 4.8 Process 1.4 Suppliers and Parts Reliability Assurance.

Figure 4.9 Process 1.5 Field Data Reliability Analyser.

Figure 4.10 Process 1.6 Costing Analysis.

Figure 4.11 Process 1.10 Reliability Predictions.

Figure 4.12 Level 2 Workflow structure.

Figure 4.13 Workflow 2.1 Failure Reporting Process.

Figure 4.14 Workflow 2.2 Corrective Action Implementation.

Figure 4.15 Workflow 2.3 Supplier qualification process.

Figure 4.16 Workflow 2.4 Component qualification process.

## Chapter 5

Figure 5.1 RFDM Front Screen.

Figure 5.2 User login to the Information Manager.

Figure 5.3 Class Buttons Toolbar.

Figure 5.4 User Interface of the Information Manager.

Figure 5.5 User workflow mailbox.

Figure 5.6 Database selection for the failure data analyser.

Figure 5.7 Failure Data Analyzer.

Figure 5.8 Parameters calculated.

Figure 5.9 Parts Failure Analyser.

Figure 5.10 Failure Modes Manager.

Figure 5.11 RFDM system launches reliability prediction software.

Figure 5.12 Steps to perform field data analysis.

Figure 5.13 Searching Parameters for Failure Analysis.

Figure 5.14 Selecting different dates for search.

Figure 5.15 Search for units SL 100, with failures.

Figure 5.16 User adds failure report to the information manager.

Figure 5.17 Field Failure Report information pages in the system.

Figure 5.18 Product type selection feature.

Figure 5.19 Failure report search parameters and conclusions.

Figure 5.20 Failure Report file information, user information and revision information.

Figure 5.21 Searching for failure reports.

Figure 5.22 Viewer page for failure report.

Figure 5.23 Specifying a failure report on part type of report.

Figure 5.24 Template for failure report.

Figure 5.25 Initiation of failure report process.

Figure 5.26 Failure report process pages of information.

Figure 5.27 Flowchart for failure reporting process.

Figure 5.28 Tasks of the reliability engineer.

Figure 5.29 Initiation of a Corrective Action Process.

Figure 5.30 Corrective action process general information.

Figure 5.31 Corrective action specific information.

Figure 5.32 Adding an update on corrective actions to the service class.

Figure 5.33 Update on Corrective Actions.

Figure 5.34 Update on corrective action summarized information.

Figure 5.35 Feedback from the dealer through the notes page.

Figure 5.36 Steps in critical item reliability.

Figure 5.37 Critical Item Information Sheet.

Figure 5.38 Adding a critical item information sheet.

Figure 5.39 Critical Item Information Sheet in the information manager.

Figure 5.40 Component is marked as critical in its profile card.

Figure 5.41 Critical Items Listing.

Figure 5.42 FMEA Analysis profile card.

Figure 5.43 FMEA field in the components profile card.

Figure 5.45 FMEA template viewer.

Figure 5.46 Supplier Qualification Process steps.

Figure 5.47 Initiation of a Supplier Qualification Process.

Figure 5.48 Supplier Qualification Process.

Figure 5.49 Flowchart and tasks in the supplier qualification process.

Figure 5.50 Reliability Assessment Template.

Figure 5.51 Supplier qualification Information.

Figure 5.52 Component qualification steps.

Figure 5.53 Component qualification template within the information manager.

Figure 5.54 Reliability parameters documentation in the system.

Figure 5.55 Reliability Predictions.

Figure 5.56 Reliability Predictions Profile Card.

Figure 5.57 Reliability specifications for a component.

Figure 5.58 Information page for reliability requirements.

Figure 5.59 Template viewed for reliability requirements.

## **Chapter 6**

Figure 6.1 Integrated approach to reliability summary.

Figure 6.2 Layout of the Reliability and Field Data Management System.

Figure 6.3 Further developments for the RFDM System.



# List of Tables

## Chapter 2

Table 2.1 Cost of Unreliability Analysis.

Table 2.2 Goal Setting Check List.

Table 2.3 Reliability Specification.

Table 2.4 Reliability Initiatives and Methodologies .

Table 2.5 Load-Strength Analysis.

## Chapter 3

Table 3.1 Analytical requirements of the reliability information system.

Table 3.2 Efficiency/Integration requirements of the reliability information system.

Table 3.3 Comparison of analytical requirements for reliability software packages.

Table 3.4 Comparison of efficiency/integration requirements for the reliability software packages and product data management systems.

## Chapter 5

Table 5.1 Customized structure of data in the PDM System.

# Chapter 1

## Introduction

- 1.1 Thesis Motivation
- 1.2 Objectives of the Thesis
- 1.3 Approach to Work
- 1.4 Thesis Structure

### 1.1 Thesis Motivation

Reliability engineering is a rapidly growing activity in industry today. It originated as such during the 1950's as a response to the demanding pressures in companies and products. Considerations such as life cycle costs, cost of ownership, product safety, liability or product reputation means that a company needs to be able to predict, assess and guarantee the operation and use of the product well after the production release. Reliability is the attribute of a product that includes every step of the life cycle of the product, from concept to disposal. The reliability effort in a company needs to be addressed by the implementation of a reliability program that deals with all the different aspects of reliability in the life cycle, and establishes interaction and communication between them. Also in many cases, it involves developing specific paths for retrieval of support phase information, since this stage of the life cycle offers the best feed-back on product operation and performance.

However, improving reliability is not the only new challenge that the organization has to face. In the recent years there has been powerful worldwide changes that have altered the environment of business. Firstly, increased competition and market pressure have resulted in short release cycles. Teamwork has been greatly enhanced, and product development processes have been revolutionized with implementation of *Concurrent Engineering* techniques. As a result of this, new tools have been introduced in the engineering environment, e.g. *Computer Aided Engineering*, and networked systems have made virtual teamwork possible.

Secondly, the business environment has also become global, and companies need to collaborate and interact with customers and suppliers that can be in different countries or

continents. Finally managing information, and maximizing the knowledge resources has become more and more important as the economies in the developed countries move towards a knowledge and information based model. Information systems provide the communication and analytic power that firms need for conducting trade and managing business on a global scale, and support the organization in developing its activity and its knowledge building effort.

The reliability activity can also profit from the information technology resources and in order to achieve its goals in this global, and collaborative environment, it needs to be supported by efficient information structures and systems. Therefore it seems suitable to develop the reliability program through information management structures and to implement reliability initiatives based and supported by these structures.

The following thesis, describes and prototypes an integrated approach to reliability management and operation, supporting the reliability activity with information systems, as the means of managing data, procedures and methodologies.

## **1.2 Objectives of the Thesis**

The research, which this Masters thesis is based on, is embedded into an industrial research project, entitled Reliability and Field Data Management for Multi-Component Products. The main objective of this project is to develop a prototype of a system to manage reliability and field information, both in data and in processes. This system should provide the means for retrieving data, should integrate tools and methodologies in order to analyze it, and should be capable of storing the outputs of the analysis efficiently, in order to support knowledge building [Roc97].

The objective of this thesis is to develop a model for the reliability program operation, by approaching reliability as a process integrated with the life cycle of the product. It is also the purpose of this thesis to select, based on the requirements of the reliability model, a system that will support the operation of this program.

A prototype of this system will be developed in order to prove these concepts and to illustrate the different models and structures proposed in the research.

## **1.3 Approach to Work**

The research started with a study of different reliability methodologies and initiatives, both through literature reviews, and through a close relationship with the industrial partners, and their reliability engineering operations. Based on the experience gained through these

means, a model of reliability process was created in order to give structure to the reliability program. The requirements and needs of the program were outlined. This was followed by close research into the different information tools available for reliability work, which included the use of different software packages, and the evaluation of their features and functionality. As a result of this evaluation, Product Data Management Systems (PDM) proved to be the most suitable technology framework for reliability management, and therefore research into different PDM solutions and packages was carried out. SmarTeam PDM has been selected because of its flexibility, its integration with CAD and Office packages and its ease of implementation. The suitability of PDM systems to support reliability management has been tested through the customisation of the SmarTeam Software, and the integration of the software with some other specifically developed tools. The overall system has been tested with ThermoKing Europe, and their operations. All along the process of implementing the system, continuous contact and feedback from the company helped in assessment and improvement of the different aspects of its operation.

## 1.4 Thesis Structure

The thesis structure is as follows:

**Chapter One** presents the motivation, the objectives, the approach to work and the layout of the thesis.

**Chapter Two** deals with reliability concepts, by presenting the model of the process of reliability, and by describing the methodologies and initiatives involved in this process.

**Chapter Three** describes the information requirements arising from the reliability program operation. A benchmarking exercise of different solutions is presented and a review of the selected tool, i.e. PDM is given.

**Chapter Four** describes the customisation requirements and overall structure of the prototype of the Reliability and Field Data Management System that has been developed. A number of reliability initiatives will be specified.

**Chapter Five** presents the prototyped Reliability and Field Data Management System, its information structure and interface. It will also show the way in which, within the system, the reliability processes are carried out, and the automation of some processes.

**Chapter 6** will review conclusions and recommendations from the research and the development of the software.

This structure is illustrated in figure 1.1.

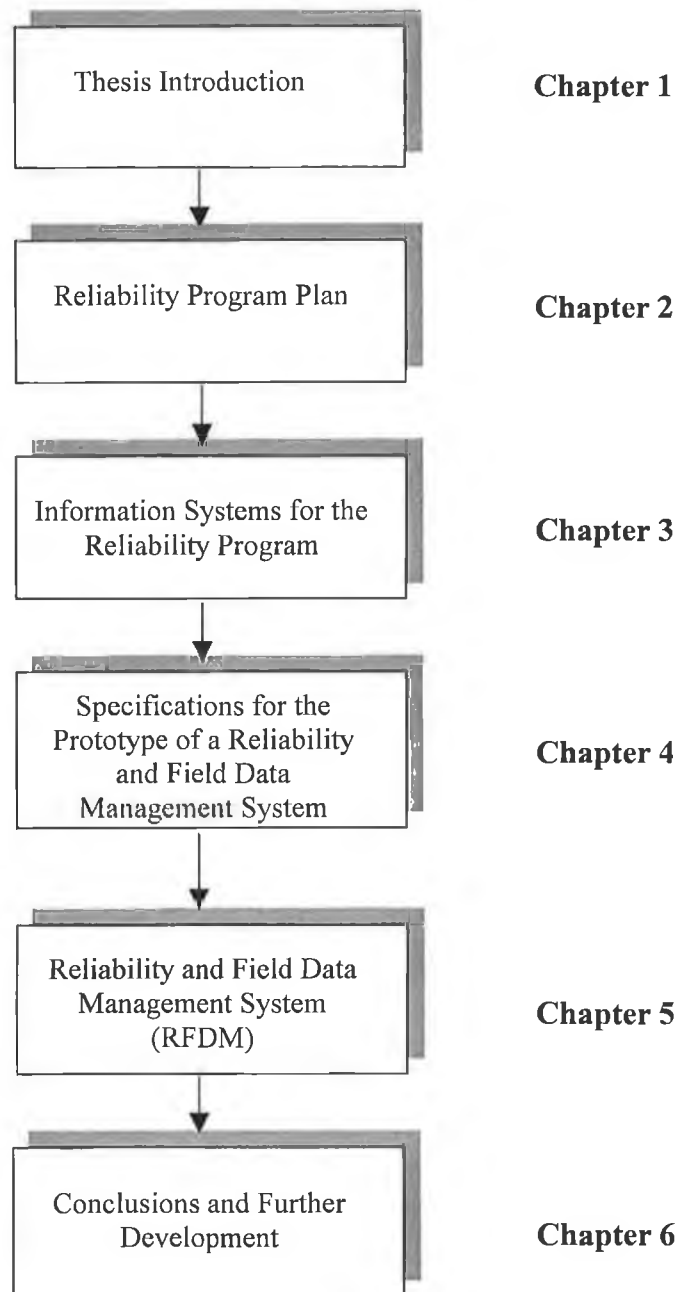

Figure 1.1 Structure of the thesis

# Chapter 2

## Reliability Program Plan

- 2.1 Introduction
- 2.2 Definition of Reliability
- 2.3 The Process of Reliability
- 2.4 Program Management and Control
- 2.5 Program Initiatives
- 2.6 Supplier Reliability and Quality Assurance
- 2.7 Design for Reliability
- 2.8 Statistical Methods and Models in Reliability
- 2.9 Reliability Testing
- 2.10 Reliability in Manufacture
- 2.11 Maintenance Strategies
- 2.12 Failure Analysis, Root Cause and Corrective Action
- 2.13 Structure for the Reliability Program
- 2.14 Summary

### 2.1 Introduction

Reliability engineering is a very extensive area of engineering that covers many different aspects. It shares some contents with various other topics, such as quality, statistics, mechanical engineering or management. A comprehensive approach needs to combine the relevant aspects of each of the concerned areas into a reliability structure. Developing reliability structures in a practical way is strongly influenced by the product, the type and size of the organization and its market position. Depending on these factors certain approaches would prove to be more efficient, than others. Reliability needs to be customized to the needs of the organization.

The aim of this chapter is to specify clearly the components of the structure that supports an integrated approach to reliability management. The chapter will begin with a definition of reliability and related concepts. Then, a model for the process of implementing reliability will be shown. The different methodologies and concepts involved in this model will be reviewed next. Is the purpose of the author to integrate this methodologies and

concepts into a supporting structure. The review carried out in this chapter will outline the requirements for this structure which will be specified at the end of the chapter.

## 2.2 Definition of Reliability

Reliability has been defined as '*the probability that a component, device or system, will perform its prescribed duty without failure for a given time when operated correctly in a specific environment*' [Dav94]. This definition introduces the major aspects that need to be understood when talking about the reliability of a product: *probability, operating conditions, failure and environment*. The concept of probability is going to be the tool to overcome variation problems. The engineer's task is to design and maintain the product so that it does not fail. In these tasks he/she faces the problem inherent in the variability of engineering materials, processes and applications. *Probability laws* and statistical distributions are a mathematical tool that enables the engineer to deal with these variable parameters. Understanding what the *prescribed duty* for the product is, involves the knowledge of the production and performance specifications. *Failure* must be defined precisely, as it can take different form, i.e. a damaged, non-operating or incorrectly operating component. Finally, the influence of *environmental conditions* is also important. Products are used in very different environments, and these environments have a major influence in the possible modes of failure, e.g. corrosion or temperature brittleness.

The concept of reliability in industry goes beyond statistics and probability. In this context reliability is often used in a very general sense to include the whole of reliability-related activities: *reliability, availability and maintainability (RAM)*. *Availability* refers to the concept of whether an item will be ready, i.e. available, when is needed [Dav94]. *Statistical availability* is the fraction of time that a system is available. It is often used as a measure of system effectiveness for equipment that is used to perform a service, such as large computer or a fleet of aircraft. Availability is determined by the reliability, maintainability, logistics and administrative policy of the organization.

The word *maintainability* refers to the concept of being able to easily maintain an item, i.e. the ease and speed of proper maintenance. *Statistical maintainability* is the probability that an item will be maintained within a given period of time when the maintenance is performed by personnel having specified skill levels and using prescribed procedures and resources. Maintainability is strongly affected by logistics system, personnel skills, and design of the item [Eva99].

### 2.3 The Process of Reliability

Reliability is an approach taken by the organization towards the goal of satisfying the customer. An enterprise needs to have a holistic view of reliability as a process that relates to the life cycle of the product, i.e. from design to retirement. A process can be defined as “a collection of successive steps that takes inputs, and achieves a specified output” [Gra96]. In a business environment, value is added if actions result in a change that the customer wants, and if the desired action is done correctly fast and in a cost-efficient manner. Reliability can then be defined, from a more holistic perspective as process, i.e. a collection of successive actions linked to each of the product life cycle phases that achieve high values of reliability and quality in a timely and costly manner. A reliability program plan covers a large range of methodologies, and tactical activities throughout the product life cycle [Mor93].

Figure 2.1 shows a model of the process of reliability that the author proposes, as a high level view for reliability management within a company.

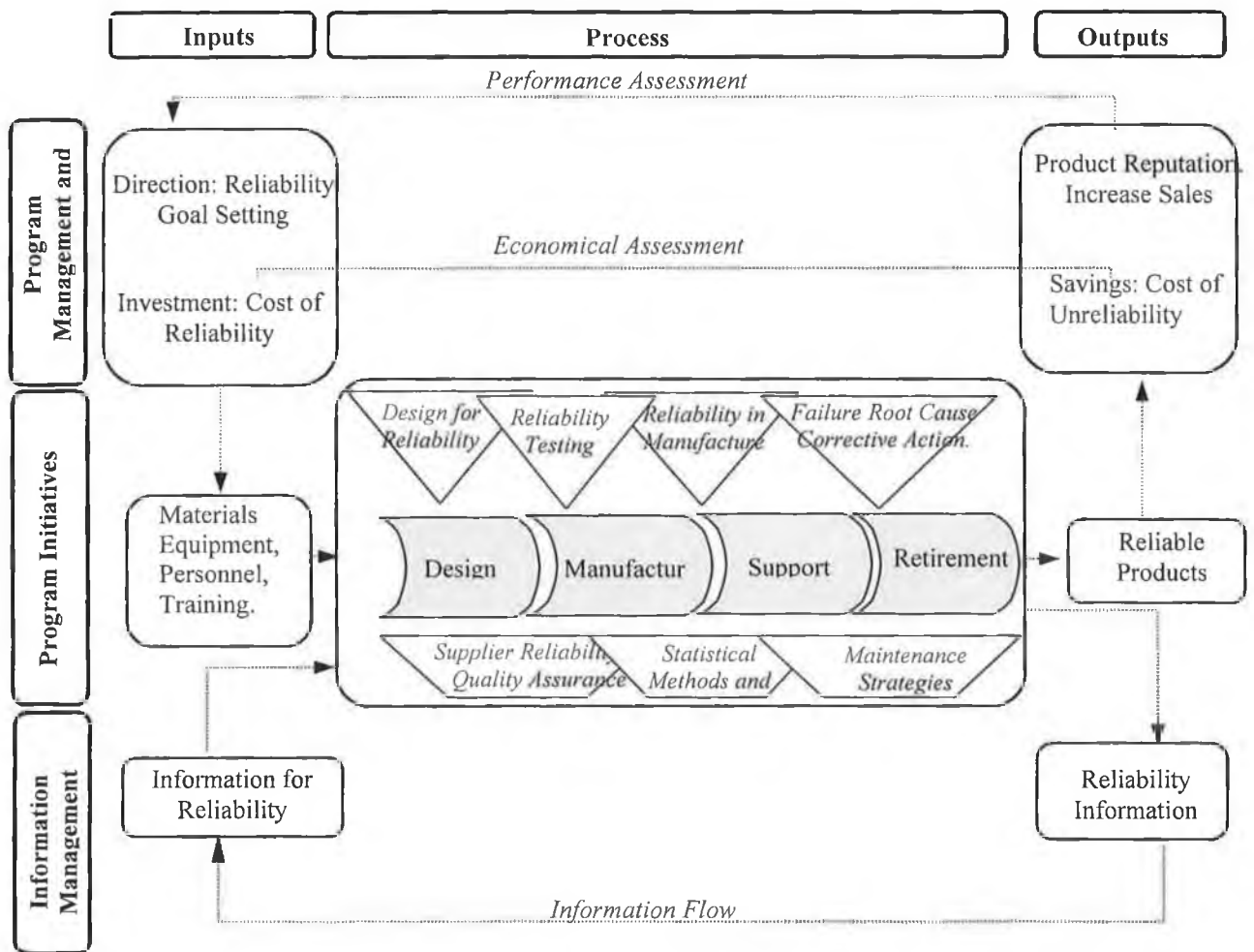

Figure 2.1 The Process of Reliability.



The model shows the process of reliability, with a set of inputs and outputs at three different levels, i.e. *program management and control*, *program initiatives* and *information management*, as shown in the vertical categories of the figure. The inputs for the *management and control level* are the goals and requirements that give direction to the program and the level of investment and resources allocated to the program and to the different initiatives. These are decided by managers and project leaders, helped in their decision by the process of *assessing performance* and *economical* improvements achieved by the program. Although at the start this assessment is based on past-experience and managerial expertise, as the program progresses, the process results in a set of outputs, such as cost savings, increase of product reputation and increase of sales, which will be parameters used for decision making. At an operational level, i.e. where the *program initiatives* carried out are shown, the inputs are obviously the equipment, materials, training and personnel dedicated to their implementation. These initiatives cover a set of methodologies all throughout the development process. The choice of methodologies used, and the emphasis in each of them will depend on the company, the product and the amount of investment. They will generally be grouped in different categories as shown in the figure, i.e. *supplier reliability and quality assurance*, *design for reliability*, *reliability in manufacture*, *statistical methods and models*, *reliability testing*, *Maintenance strategies* and finally *failure root cause and corrective action*. The output of the program initiatives has necessarily to be higher levels of reliability, better maintainability or better availability of the product. Finally the third perspective that needs to be looked at, deals with the *flow of information*. In any engineering activity having the right information at hand, is a key issue for ensuring success. This is particularly true for reliability, since it is an activity that expands throughout the life cycle of the product, and involves very different personnel and tools, at different phases. The exchange of information, the proper storage of data, and the building of knowledge and expertise through information management are essential for a successful reliability approach. Information management integrates the program in a framework for the operation of the different methodologies. It guarantees information flow and feedback, knowledge management/storage and provides convenient tools for analyzing and reporting, as to support the program, and the decision making processes.

The different issues involved in program management and control, and the program initiatives, will be shown next. The information management requirements will result from this review. Finally the possible information infrastructures for reliability management will be discussed in chapter three.

## 2.4 Program Management and Control

At a strategic level the key elements in implementing a successful reliability program are a continuous commitment of managerial level with the project and a well-defined and well-structured program, with clear objectives and tasks. It is up to the decision makers to understand and assess the need for reliability, to analyze the economics involved, to foresee the directions to take and to estimate and allocate the resources that are needed in order to do so [Oco91]. The program will have a set of outputs, in the form of parameters or reports that would help managers in their decision making process. The three major issues from a managerial perspective are the *economics of reliability*, the *reliability objectives and goal setting* and finally the *reliability activities allocation*.

### Reliability Economics

Achieving products with high reliability is a process that necessarily needs a certain level of investment and resources. It can sometimes be expensive, particularly for complex products involving state of the art technology. The benefits of effectively improving reliability of the product are sometimes difficult to measure. Apart from savings coming from warranties and liabilities, the value gained from a reliability program is to a large extent a subjective judgment, based on concepts like customer satisfaction and customer loyalty. Hence it is sometimes difficult to measure the profits that the reliability investment brings to the company.

The concept of product life cycle forms the basis of all current views of product costing and is applicable to reliability cost analysis. It involves the concept of life cycle cost, that is a holistic view of the different phases of the product, the different costs all through these phases, combined with the reliability information and evaluation of design alternatives. Costing reliability requires assessing two different categories: the cost of reliability, i.e. cost of producing a product of a certain level of reliability, and the cost of unreliability, i.e. the cost for the manufacturer if the product does not attain high reliability [Gra96].

### Cost of Reliability (COR)

The concept of cost of reliability, i.e. the total cost that the manufacturers incurs during the design, manufacture and warranty period of a product of a given reliability can be grouped in three categories, as follows [Gra96];

- Cost of failure. Yield losses caused by reliability screens and tests; cost of downtime in manufacturing equipment related to failure investigation; Scrap and

rework costs, including costs of related work in progress, space requirement for scrap and rework, associated documentation and related overheads. Cost of failure analysis in the support phase.

- Reliability Appraisal. Life testing, environmental testing, failure data reporting and analysis or reliability modeling.
- Prevention. Design for reliability, reliability standards and guidelines development, customer requirements research, product qualification, reliability screens, design review, reliability training and any other reliability activity related to the concept, design and production phases.

The cost information must be further restructured by product, process, segment or department to identify major contributors and therefore opportunities for improvement.

### Cost of Unreliability

The cost of unreliability can be viewed as the savings for the company if a reliable product is manufactured. An example of cost of unreliability is shown in the table below.

Cost of Unreliability Analysis		
Direct Costs		
1 Warranty repair costs	Number of warranted units * years of warranty contract * average cost per year	Number of warranted units from market projections. Average cost per year based on warranty analysis of product.
2 Spares production and inventory for warranty support. Spare costs	To be determined by analysis (e.g. Poisson Model, simulation)	Using inputs of call rate, proportion of calls requiring spares, spares costs, probability level of having spares in stock...
3 Net of profits on post-warranty repairs and spares	Annual profit on post-warranty spares and repair, analysis similar to warranty cost but related to post-warranty equipment utilization.	
Indirect Costs		
1 Service Organization	Training manuals, overheads during warranty period contribution	Estimate: 50% of annual warranty cost in first two years, 25% thereafter
2 Product reputation		Estimate: agreed function of call rate, or of warranty cost.

Table 2.1 Cost of Unreliability Analysis.

### Performance Parameters

The analysis of cost of unreliability can include outputs such as the cost of warranty for a single product per year, a list of frequent warranty failures or a list of top costly warranty failures. As a result of this outputs some analysis can be carried out such as comparison between different costs for ranges of products or list of critical items for a given product.

Generally the structure of the warranty, or cost of failure information is not specifically designed for doing reliability analysis. It can sometimes be necessary to redefine this

structure in order to make it more suitable, or to develop a separate entity for monitoring this cost of failures.

The service and staff character of the reliability engineering and assurance function justifies a closer look at its cost-effectiveness. Its contribution to cost savings and value creation is indirect, and therefore management metrics and goals are also indirect. The following list represents an example of a reasonable set of variables allowing performance assessment [Oco91].

- Cost of reliability engineering as a percentage of R&D cost, totals yearly and for each individual project
- Cost of reliability engineering as a percentage of cost of quality
- Cost of reliability engineering service hour, actual and compared to charges by external service companies and laboratories.
- Percentage of designers trained in design for reliability
- Percentage of service requests fulfilled on time
- Number and percentage of service requests not accepted
- Cost of reliability engineering as a percentage of warranty cost
- Product warranty failure rate
- Customer-perceived company product reliability rank relative to key competitive products.

### **Reliability Goal Setting**

For every process, program or plan in the organization, the first activity the needs to be carried out, is the establishment of a set of *goals* and *requirements* that give direction to the plan. Goals are used to focus organizational attention on desired results and to serve as standards against which achievements can be measured.

*Goals* must have a common direction, a higher purpose, but must always stay with what can realistically be supported. General procedures in order to establish goals in a reasonable manner can be developed. Table 2.2 shows a set of steps that helps establishing reliability goals and that ensures that they are ranked in an appropriate way.

<b>Goal Setting</b>	
1 Clarify what is needed or desired	
2 Review the organizational major unit purpose, establishing the goal, purposes and missions of the sub-units that conform the major one.	
3 Identify desired key result areas.	
4 Select goal candidates	
5 Determine where the highest payoffs are likely.	
6 Consider resources required to pursue each goal to a conclusion.	
7 Identify any impediments or risks to goal achievement and determine whether they can be overcome.	
8 Rank candidate goals according to ease of achievement in combination with degree of pay-off	
9 Consider goal interdependencies and adjust goal candidates for maximum coordination and mutual reinforcement.	
10 Examine goals for relevance, attainability, supportability, compatibility and acceptability.	
11 Make final selection of goals and establish deadlines for achievement	
12 Develop action plans for key goals. Translate them into requirements.	
14 Communicate goals in writing.	
15 Periodically review progress toward goal achievement and adjust.	

Table 2.2 Goal Setting Check List.

Some examples of goals set in the context of a reliability program plan would be as follows;

- Establish reliability requirements or values.
- Define the structure that has to be put in place for supporting reliability activities, with a time frame to have it efficiently operative.
- Specify the data collection procedures or systems; allocate responsibility and time frame to have it efficiently operative.
- Specify an information management system that links the different activities, and serves as foundation for the program. Time frame.
- Design the training program, personnel recruitment, and exterior services if necessary.

### **Reliability Requirements**

Translating goals into *requirements* is absolutely necessary for connecting the strategic perspective to the engineering activity. The requirements are the final measurable parameter that will allow project leaders, engineers, managers and customers to assess and decide whether value added by reliability is sufficient or not. Two common parameters used are MTBF when a constant failure rate is assumed, and a B-life, related to Weibull life distributions. Requirement should be integrated into a reliability specification that

includes a definition of the failure modes, a description of the environment, and finally the statement of the reliability requirement. An example of reliability specification is given in the table 2.3. range of other specifications.

Reliability Specifications	
Part Name	Engine 2.2 liters
Part Number	23-0798
Definition of Failure	Engine stops transmitting power. (1) Engine runs with high level of noise. (2) Engine runs with extra need of fuel. (3) Excessive Vibration. (4)
Environmental Specifications	Engine Speed; 2200 rpm Engine Load:
Reliability Requirements	Mean Time To Failure (1) 35.000 hours No failure before 25.000 hours Weibull distribution two parameters (SA 1001)*

Table 2.3 Reliability Specifications.

### Reliability Activities Allocation

The program surveillance and control tasks usually rely in managerial positions with the adequate feedback and inputs from reliability engineering activities.

The rest of the activities that are integrated in the product development process should be allocated among engineering personnel. It is important to understand that these tasks are not specific of the reliability engineers. In the same way that all the aspects of product development are involved in reliability improvement, an efficient reliability plan requires all the personnel involved in this process to collaborate in fulfilling these tasks, with the support of training, reliability engineers or reliability experts. Consultancy can be an option considered in certain situations, but if the organization has recognized the need for implementing the program it is always desirable to build in the expertise within the company. Some of the functions that are specifically assigned to reliability personnel are doing reliability estimation/prediction and growth plans, participating in all design reviews and maintaining reliability data systems

## 2.5 Program Initiatives

Reliability is ultimately a process related to the life cycle of the product. The life cycle of the product is the process of developing, manufacturing, commercializing and maintaining a product. Therefore reliability is a process with a set of steps that are heavily influenced

by the product life cycle. Creating a reliable product requires defining, assessing and maintaining reliability throughout the phases of the product life cycle [Wgra96].

Therefore the reliability activities and methodologies are usually structured in groups, and each of these groups is tied to a certain phase of the life cycle of the product. Table 2.4 shows the groups selected for the purpose of this research.

<b>Supplier Reliability and Quality Assurance</b>	Product Selection and Evaluation Supplier Qualification Process & Audits Incoming Inspection.
<b>Design for Reliability</b>	Environment Analysis Load-Strength Analysis Failure Mode Effect & Criticality Analysis Fault Tree Analysis Critical Items List Design reviews Thermal Design & Worst case Analysis
<b>Statistical methods and Models in Reliability</b>	Statistical Analysis of Data Life-Time Distributions Probabilistic Engineering Design Reliability Modeling and Prediction Reliability Allocation
<b>Reliability Testing</b>	Planning Reliability Testing Environmental Testing Accelerated Testing Endurance Testing
<b>Reliability in Manufacture</b>	Reliability in Manufacture Quality
<b>Maintenance Strategies</b>	Reliability Centered Maintenance Computer aided maintenance/troubleshooting
<b>Failure Analysis-Root Cause and Corrective Action</b>	Failure Analysis Structure Failure Analysis & Corrective Action Process

Table 2.4 Reliability Initiatives and Methodologies.

## 2.6 Supplier Reliability and Quality Assurance

It is very common in engineering companies that a substantial proportion of the finished product consists of components produced by suppliers. Therefore, if a successful reliability plan is to be implemented, it is necessary to monitor supplier quality and reliability and to find a way of assuring it meets the specifications set for the final product [POc92].

The three major issues to consider:

- Evaluation of products and suppliers;
- establishing the right communication and information paths with your chosen suppliers;
- carrying out a monitoring or control activity throughout production of products in order to maintain initial parameters.

## Product Selection and Evaluation

The most important task in product acquisition is selection of the correct product. This involves comparing alternatives, but even if there is seemingly no choice it is still necessary to evaluate whether the item that is, or will be, available will meet the intended application's requirements.

The facts involved in product evaluation fall into two groups: product effectiveness and product cost. Cost factors should not be included since the effectiveness of a product should be assessed versus the cost, using this term to mean Life Cycle Costs (LCC), and not just acquisition price. Effectiveness is best assessed in terms of a combination of the characteristics relevant to the system or product, these include capability, functional quality, legal factors, and of course reliability, durability and maintainability [Bla92].

Evaluating product's reliability can be difficult. Most supplier-written product specifications give only very limited, if any, reliability information and, even when some reliability figures are given, it is often uncertain just how dependable and how applicable to ongoing production they are. Some actions that permit reliability evaluation are:

- Verification that the product's operational and environmental requirements are within specification.
- Verification that the supplier has an adequate quality assurance system.
- An enquiry about which reliability assurance tasks were performed during design and development such as environmental stress analysis, parts stress analysis, FMECA, formal design reviews or reliability growth testing.
- Enquiry and evaluation concerning product qualification testing.
- Enquiry and evaluation as to the reliability screening, e.g. burn-in and environmental stress screening (ESS).
- Enquiry as to the production acceptance testing performed prior to release for delivery.
- Assessment of any quantitative reliability data supplied by the producer, either as part of the product data sheet or documentation or on request.
- Evaluation of failure detectability. This is important for functional modes

A common way of describing reliability requirements is through a reliability figure or merit, such as mean time between failures, failure rate, mean time between maintenance or availability. The customer will typically specify the desired figure or merit contractually in engineering documents, and will base it on system criticality or safety; reliability of available components; target cost; and repair, replacement, servicing and maintenance costs [Dav94].



### **Supplier Qualification Process & Audits**

The supplier's product is a result of its processes, from design to shipment. Determining which supplier has the best processes, or at least the willingness to continually improve its processes, is much better than exhaustively inspecting and testing the product, hoping to detect defects or process changes before they are installed in the product. Once the best supplier candidate is selected, the surest way to achieve high reliability is to work with that supplier, starting with the design process, and then continuing through manufacturing, test, and shipping. It is responsibility of the project leader and/or manager of the reliability activity to create and maintain this mutual

It is a good idea to set up continuing monitor of the supplier's processes. It is also interesting to track the factory and field failure rates and feed this information back to the supplier on a regular basis [Gra96]. The reliability specifications coming from the suppliers, their test procedures, their analysis of failures and every other document related to reliability, must be available for the project leader and personnel involved in the reliability activity.

### **Vendor Rating**

Vendor rating schemes have the purpose of providing a measure of vendor performance in the areas of quality and service in order to permit comparative assessment of competing suppliers, to draw attention to weaknesses, and to encourage vendor to improve their performance by making them aware that it is monitored [Bla92]. Rating schemes are usually based on quality and service measures. Quality indicators include possession of quality systems, percentage of product rejected, or failure rate. Service indicators can be punctuality of delivery, response time to enquiries or willingness and ability to respond to requests.

### **Incoming Inspection**

The incoming inspection of components and parts received from suppliers in a regular basis is a common practice in industry today, and it does not need further description. From the conventional random sampling techniques, to the statistical designed sampling methodologies, some of the issues to be considered are setting standards, calibration and testing methods, determining parameters to be judged, establishing sampling plans, and frequency of inspection, etc. Convenient reporting of this and of the results from inspection is absolutely necessary for making it an efficient process.

## 2.7 Design for Reliability

The reliability of a product is strongly influenced by decisions made during the design process. Deficiencies in design affect all items produced and are progressively more expensive to correct as development proceeds. It is often not economic or possible to change a design once production has started. Therefore it is essential to focus in disciplines at this stage, that minimize the possibility of failure and which allow design deficiencies to be detected and corrected as early as possible [Dun80].

Apart from the methodologies that will be shown next, the designer must be aware of the materials, processes, components, production methods, design rules and guidelines, costs and much else in order to create a good design.

### Environment Analysis

Environmental analysis consists on a careful review of the environments in which the product is expected to be stored, operated and maintained. The assessment must include all aspects that could affect the product's operation, safety and reliability. Physical factors include temperature, vibration, shock, humidity and pressure. Environmental aspects should be reviewed systematically, and the review should be properly documented [Car97]. The protective measures to be taken must be identified, as appropriate to storage, transport, handling, operation and maintenance. Environment analysis must be compulsory for critical components. It is also important that it takes a standard form to allow flexible exchange and proper interpretation of its results.

### Load-Strength Analysis

Load-Strength analysis is a procedure to ensure that all load and strength aspects have been considered in deriving the design, and if necessary in planning of tests [Kap77]. The table below is an example of a hypothetical load-strength analysis for an assembly. The example shows approaches that can be used for different aspects of the analysis.

Item (mat, func)	Worst case load/combined	Frequency/prob of occurrence	Data source	Combined effect	Strength	Remarks
Rivet (*4) (Aluminium, fixing bracket to plastic frame)	1. 50 N total, axial	Continuous	—	—	Plastic frame is weak link	Life test to confirm Thickness of plastic frame at bracket attachment may be critical feature
	2. 40 N, lateral impact	See load distribution annex 1	Operating Data	Combine with 1 Degradation		
	3. Temperature 0-35°C			NIL	NIL effect	
Solenoid Coil	1. 32 V (at 27°C)	1/10 <sup>4</sup> h	Data on power supply variation	72°C	Insulation limited to 70°C	Overvoltage protection or improved cooling needed
	2. 45 <sup>th</sup> ambient	1/10 <sup>2</sup> h				

Table 2.5 Load-Strength Analysis.

Event probabilities can be expressed as full distributions, or as the likelihood of a particular limiting case being exceeded [Car97]. The former is more appropriate when the load can cause degradation, or if a more detailed reliability assessment is required.

### **Load Strength Interference**

In conventional design, failure is prevented by assuring that the design's strength exceeds the applied load with an adequate safety factor. Load and strength have to be considered in the widest sense. Load might refer to mechanical stress, voltage or temperature and strength describes physical properties such as hardness, strength or melting point. In the real world, the values for strength and load depend on a set of conditions, and therefore vary with those, so that they may be more accurately represented by a statistical distribution [Car97]. This approach is called probabilistic engineering design, and will be described further in the section dedicated to statistical methods section.

### **Failure Modes, Effects and Criticality Analysis (FMECA)**

This methodology is probably the most widely used and most effective reliability analysis method. It is extremely relevant in the design process. It obliges the design team to review their developments and involves other engineers in this process so that an external source, with different perspective can also participate in this process. The principle of FMECA is to consider each mode of failure of every component of a system and to ascertain the effects on system operation of each failure mode in turn. Failure modes are then classified in relation to the severity of their effects [Gra96].

An FMECA intends to:

- Recognize and evaluate the potential failure of a product/process and its effects.
- Identify actions that could eliminate or reduce the chance of potential failure occurring.
- Document the process.

Ideally the best results are obtained when an appropriate team is gathered to perform the analysis. Using the collective knowledge of the team helps to assure the development of both a reliable product and a reliable process. The core FMECA team should be cross-functional in nature and include product engineers (component and system), manufacturing or assembly process engineers, reliability engineers and quality engineers

The FMECA requires a great input of information. Some of information that is usually required for an efficient analysis is [Sta97]:

- Past Experience. Historical documents describing similar products, materials and processes.
- Present Needs. Design specifications, checklists, guidelines and rules.
- Overall Requirements. Customer's requirements. Functional specifications. Usage environments. Requirements for shipping, handling and storage. Government and safety regulations. Standards including internal policies and/or objectives. Recyclability requirements.
- Other Information Sources. Process flow diagrams, control plans, manufacturing feasibility studies, previous data on reliability/warranty/field service/customer returns. Quality function deployments, competitive quality studies.
- Block diagrams. Hierarchy block diagrams, functional block diagrams or reliability block diagrams

The FMECA should be performed iteratively as the design evolves, so that the analysis can be used to influence the design and to provide documentation of the eventually completed design. Tests results should be used to update the analysis [Bow99].

### **Fault Tree Analysis (FTA)**

Fault tree analysis (FTA) is a reliability/safety design analysis technique, which starts from consideration of system failure effects, referred to as 'top events'. The analysis proceeds by determining how these can be caused by individual or combined lower level failures or events. It differs from FMECA in being strictly a top-down approach and in considering multiple failures as a matter of course. Different FTA have to be constructed for each defined top event which can be caused by different failure modes or different logical connections between failure events [Car97].

Quantitative Evaluation of the FTA can be carried out if probabilities of occurrence values are known. In most cases, it will be more convenient to use computer software to perform these calculations. The logical approach of the FTA is very useful for system safety analysis, to assess potential hazards. The FTA is also an excellent reference for troubleshooting techniques and maintenance manuals, because of the way it starts with atop-level fault and deductively determines the root causes. Finally the FTA can also be used throughout the designing team as a reference document for a number of other reliability activities, such as failure analysis, design-level FMEA, process-level FEMA and design reviews.

An example of a Fault Tree Analysis is given in the figure 2.4.

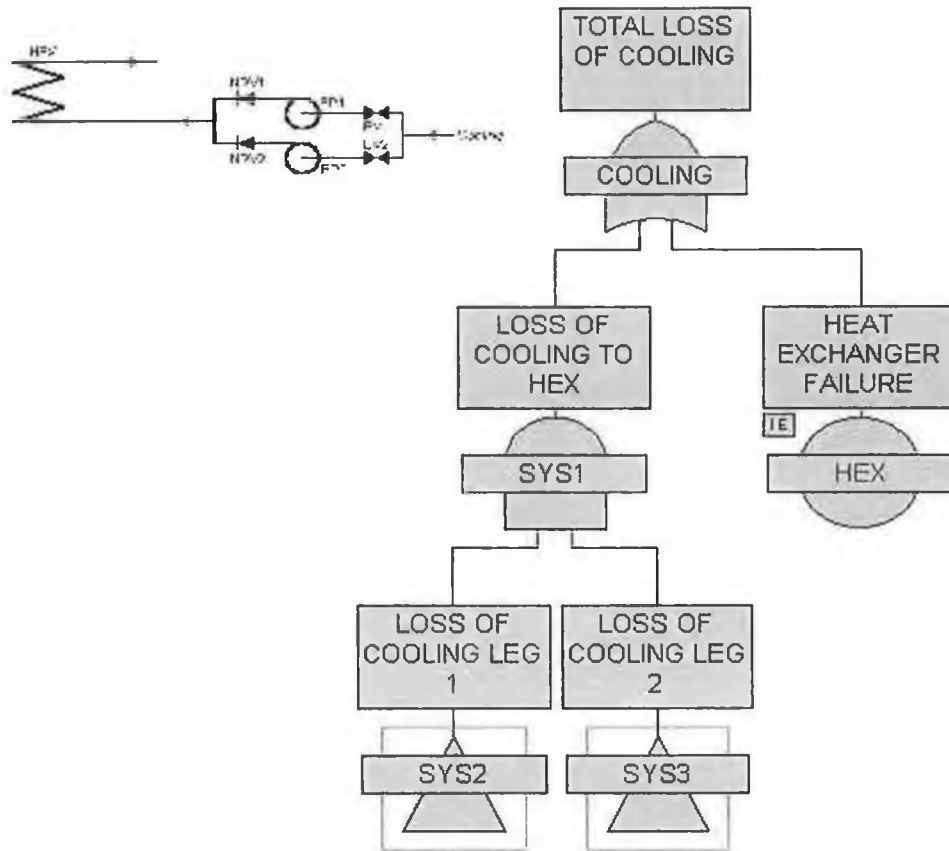

Figure 2.2 FTA of a Cooling system.

### Critical Item List

The critical items list is a summary of the items shown by the other analyses to be likely either to have an appreciable effect on the product's reliability or to involve uncertainty. Its purpose is to highlight these items and summarize the action being taken to reduce the risks. The initial list will be based upon the design analyses, but updated will take account of test results, design changes and service data as the project develops. The critical items list is a top document for management reporting and action as it summarizes the important reliability problems [Oco91]. Therefore, it should not usually include more than ten items and these should be ranked in order of criticality, so that management attention can be focused upon the few most important problems. The critical items list should provide only identification of the problems and a very brief description and status report, with references to other relevant reports.

### Design Reviews

During any design process it is highly desirable that occasional formal meetings, known as design reviews or milestone reviews are held. These sessions should ideally involve all

those concerned with the design, both to review progress and to ensure adequate communication. The number of reviews required depends on the size and importance of the project. In general about three major reviews are considered adequate, though additional minor reviews may be necessary [Car97]. To be of continuing value, the design analyses must be updated continually as design and development proceed. Each formal review must be based upon analyses of the design as it stands and supported by test data, parts assessments, etc. The analyses should be scheduled as part of the design program, with design reviews scheduled at suitable intervals. The reviews should be planned well in advance and the designer must be fully aware of the procedure. All people attending must also be briefed in advance, so they do not waste review time by trying to understand basic features. Therefore, all attendees must be provided with a copy of all formal analysis reports such as reliability objectives, predictions, load-strength analysis, critical items list, FMECA, FTA, and a description of the item with appropriate design data such as drawings [Oco91].

The design reviews should be major milestones in a project's evolution. They are not concerned solely with reliability, of course, but reliability engineers have considerably influenced the ways that modern design reviews are conducted, and design reviews are key event in reliability programs.

### **Thermal & Worst Case Design**

Thermal design is simply the practice of designing a product so that every component experiences the smallest possible temperature rise and never exceeds a reasonable percentage of its maximum temperature rating. Not only does this design approach increase the reliability of the product, but it also can improve performance when hot. Because the heat generated by one part can affect a neighboring one, thermal design is not an easy task. Also, heat is transferred by three mechanisms: conduction, convection and radiation. They are not linear and they are affected by ambient temperature, altitude, relative humidity and air velocity. Quite sophisticated thermal analysis and simulation software programs which can perform three-dimensional modeling rapidly and accurately are available [Kap77].

Worst case analysis obviously interacts with thermal design, since maximum input or output will generally result in maximum temperature rise. Other elements of worst-case analysis involve maximum variations in power supply voltage, timing or signal frequency, and component parameter tolerances.

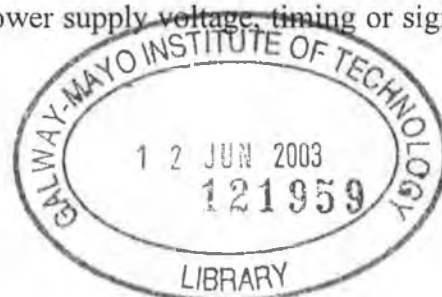

## 2.8 Statistical Methods and Models in Reliability

The traditional approach of engineering towards failure has always been deterministic. In this approach, there are a certain number of parameters, fixed values that describe the problem, or the causes of failure. However, when dealing with reliability, this approach is not valid anymore. An engineer cannot talk about the number of failure for a determined type of component, but to the probability of failure. Variation is inherent in all manufacturing processes, and designers must understand the nature and extent of possible variation in parts and processes used [Oco91]. Statistical methods provide the means for analyzing, understanding and controlling variation.

### Reliability Functions

The measure of reliability of an individual component is its lifetime, that is the time elapsing between its start of life and the time at which it fails. Although, the variable is usually refer as time, and represented as  $t$  it can represent any suitable measure of component usage, and it is a matter of engineering judgment to choose the right one. The symbol  $t$  may refer to elapsed time, operating time, distance covered, number of missions, or number of on/off operations [Dav94];

The value of  $t$  at which failure occurs, is, of course unknown in advance. It is a random variable, which needs a probabilistic rather than deterministic approach. The key to modeling the lifetimes of a series of components of the same type is the concept of lifetime probability distribution. The *Probability Density Function (pdf)*,  $f(t)$  represents the distribution over time of the probability of a components or part failing at a time  $t$

At any value of  $t$ , the probability that the component has failed at or before this time is the area under the curve to the left [Dav94]. This defines a new curve, called the *Cumulative Distribution Function*, and is denoted by  $F(t)$ . At any point  $t^*$ , the cumulative distribution function gives the value for the integral of the probability density function from  $t=0$  to  $t=t^*$ . So at every point  $t$ , the value given by  $F(t)$  is the probability that the component has failed at or before the time  $t$ , and this is generally referred to as the probability of failure at time  $t$ . Reliability has been defined as the probability that the component has survived to time  $t$ , and this is exactly the complement of the cumulative function, i.e. The fourth interesting function that is studied in the context of reliability statistics, is the *hazard rate function* or *failure rate function*,  $h(t)$ . At time  $t$ ,  $h(t)$  is the probability of failure, given survival to time  $t$ . A constant hazard rate means that the likelihood of a failure is independent of the age of the component. This is the case when failure is due to random

causes that are not dependent upon component age. Constant hazard rate is sometimes used because it is mathematically much simpler.

Increasing hazard rate implies that the component gets more likely to fail as time passes. This happens when the properties of the component wear out with the passage of time i.e. the components get old. This will occur in any situation where corrosion, wear or fatigue are present. Therefore it is the most common hazard rate behavior when dealing with mechanical components.

A decreasing hazard rate is found when the component gets less likely to fail, as it gets older. A common situation where this could happen is when the component is highly stressed due to misalignment and the stress is reduced as the component deforms elastically [Dav94].

### **Expected Life, Mean Time to Failure, MTTF and Mean time Between Failure, MTBF**

The expected life, or the expected time during which a component will perform successfully, is defined as the integral of the reliability function, i.e. an average of the survival time. When the system being tested is renewed through maintenance and repairs,  $E(t)$  is also known as the mean time between failures or mean time to failure. The mean time to failure, should be used when the failure distribution function is specified, because the reliability level implied by the  $MTTF$  depends on the underlying failure distribution. Two failure distributions can have the same  $MTTF$  and yet product different reliability levels [Kap77].

### **Life-Time Distribution Functions**

A statistical distribution is fully described by its *pdf* or probability density function<sup>1</sup>. All the other functions commonly used in reliability engineering, can be determined directly from the *pdf* definition. Once the shape of the *pdf* function is defined, all the other relevant functions, i.e. the reliability function, the failure rate function, and all the statistical parameters can be calculated [Rel97].

The *pdf* function can have different shapes, and there are a number of standard shapes, that can be found in any statistical book. These functions are called *lifetime distributions*, and are usually mathematical distributions with certain parameters, that have proven to represent pretty accurately probabilities of processes from the real life. This means that these distributions developed mathematically fit experimental data coming from real world processes, tests or data. Once a distribution is associated with a real life process, predictions and calculations can be made using the statistical model. This is the basis of

---

<sup>1</sup> More information and details on the distributions used in reliability work are given in appendix 1.



reliability assessment and reliability predictions. Some of the most common distributions used in engineering problems are the *Normal*, the *Lognormal*, the *Exponential*, the *Weibull*, and the *Gamma* distribution functions. Methodologies have been developed in order to assign the appropriate mathematical distribution to a real life behavior. The first step generally consists of designing and carrying out tests with a representative sample of population. The results of these tests are then plotted following certain directions (that depend upon the type of analysis). The remaining task is fitting a curve to these points that proves to simulate the real behavior with a certain degree of confidence. Choosing the right curve is a matter of experience and of having sufficient quality data. The use of software tools can speed up the process, and facilitate calculations and comparison of different options. There are a number of statistical methods and procedures to assess the process.

### **Probabilistic Engineering Design**

The basis of the concept of reliability is that a given component has a certain stress resisting capacity; if the stress caused by the operating conditions exceeds this capacity, failure occurs. The traditional design approach, which is based on arbitrary multipliers such as safety factors and safety margins, give no indication of the failure probability of the component. In some cases, using a safety factor above a certain preconceived magnitude can be the solution for a component failure, but in most of the cases, the failure probability may vary from a low to an intolerably high value for the same safety factor. Using a safety factor is justified only when its value is based on considerable experience with parts similar to the one under consideration [Kap77].

It seems then, that the conventional design approach is not adequate from a reliability perspective, and for a number of years, a new approach based on statistical analysis has been developed<sup>2</sup>. This methodology does consider the probabilistic nature of the design that is needed in component reliability. This is the so-called probabilistic design. In summary, this methodology identifies explicitly all the design variables and parameters, it determines the stress and the strength distributions, and then calculates the probability of failure of the component, by looking at the probability of interference of stress and strength distributions.

---

<sup>2</sup> A more detailed description on probabilistic engineering design is given in appendix 2.

## Reliability Modelling and Prediction

An accurate prediction of the reliability of a new product before it is manufactured or marketed is obviously highly desirable. Depending upon the product and its market, advance knowledge of reliability would allow accurate forecasts to be made of support costs, space requirements or warranty costs [Oco91]. Even for current products, finding reliability parameters, allow engineers to assess improvements, market personnel to use it as sales tools, and the business planers to asses the benefits of different maintenance and service contracting procedures.

### Reliability Block Diagrams

A reliability model is usually built in the same way as design block diagrams<sup>3</sup>. The system is represented trough a series of blocks, each of these block being a sub-system or component. The blocks are connected on a functional or logical way, and show redundancies, series operation or parallel configuration. Specially when dealing with mechanical components, reliability and availability prediction and modeling of systems can lead to complex problems even for the simplest products when items like repair times, testing and monitoring are taken into account. However they can be useful as a form of design review. The series configuration is probably the most commonly encountered model and, fortunately, is also the simplest to analyze. In a series system all subsystems must operate successfully if the system is to function. A parallel system is a system that is not considered to have failed unless all components have failed. In reality the standby redundant and share parallel arrangement are more often used, particularly in mechanical systems [Kap77]. Simple combinations of parallel and series subsystems are easily analyzed by successively collapsing subsystems into equivalent parallel or series components. An example would be the arrangement shown below.

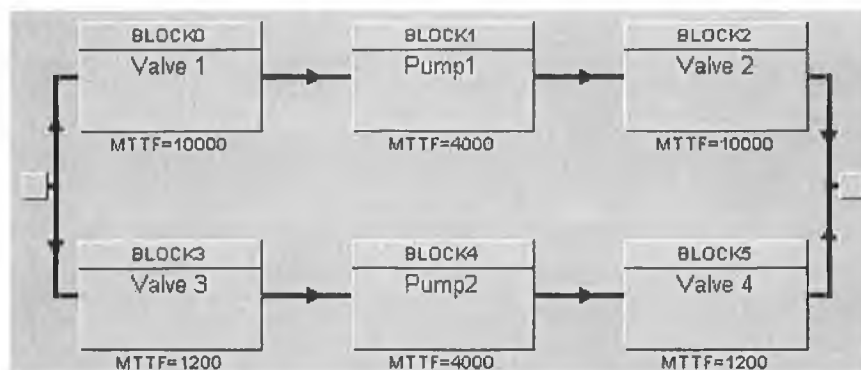

Figure 2.3 Reliability models: Series and Parallel System.

<sup>3</sup> Further details and information on reliability block diagrams simulation can be found in appendix 3.

## Reliability Prediction

The most interesting part of this section, as to mechanical reliability, and for the purpose of this project, is that of assigning parameters or values to these blocks that simulate somehow the behavior of the part or component.

This is the direct result from the statistical analysis that models the lifetime of the component with a lifetime distribution, from those covered earlier on in this section. The process of doing this consists of obtaining life time data, preparing the data for the analysis, finding the best-fit distribution for the data obtained and determining the parameters of the distribution for that particular component. Finally a decision is to be made on what parameters represent better the behavior of the component with time, and give more information on the reliability of the component [Bla92].

Some of the most commonly used parameters are listed below;

- **Failure Rate.** The failure rate of a component, as defined before, is the rate of failure of the component, i.e. the probability of failure given survival to that point. The fact that the failure rate is increasing, constant or decreasing gives a good first bit of information as to what is expected to happen, and what failure mode is relevant.
- **Mean Time to Failure (MTTF).** The mean time to failure is like an average of the number of hours that the component will last. It is applied to non-reparable components. It is an interesting parameter, and it must be always considered, but it can also be misunderstood. The fact that a component has a large mean time to failure, does not exclude the possibility of having a considerable number of components failing at early hours.
- **Mean Time Between Failures (MTBF).** This concept is generally applied to all sort of components, when in reality it can only be used in the case of repairable items. Whilst the sub-systems and parts will have a MTTF, the system as a whole, will have an MTBF, that is built from the different MTTF's of the components. However if a reliability block diagram has not been developed for the system, as it is usually the case in complex products, the MTTF is meaningless.
- **B life for Weibull distributions.** When a Weibull distribution is used to reproduce the reliability behavior of the component, a useful parameter to be given is the B life. B10, refers to the number of hours at which 10% of the components would have failed. Depending on the percentage of failure that the component has, one percentage or other is chosen for this parameter.
- **Risks numbers.** The risk number is the percentage of components that are likely to have failed for a given number of hours. It is somehow the opposite concept to the B

life, and together with the mean life, it can also give a good picture of what number of failures to expect from a component.

### **Monte Carlo Simulation**

In a Monte Carlo Simulation, a logical model of the system being analyzed is repeatedly evaluated, each run using different values of the distributed parameters. The selection of parameter values is made randomly, but with probabilities governed by the relevant distribution functions [Oco91].

Monte Carlo Simulation can be used for system reliability and availability modeling, using suitable computer programs. Since Monte Carlo simulation involves no complex mathematical analysis, it is an attractive approach. It is a relatively easy way to model complex systems, and the input algorithms are easy to understand. There are no constraints regarding the nature of input assumptions on parameters such as failure and repair rates, so non-constant values can be used.

### **Markov Analysis**

Markov Analysis is one of the so-called state-time analysis. This analysis is applied when the system or component can be in one of two states, e.g. failed, non-failed, and if the probabilities associated with these states are known. The Markov method can be applied to reliability predictions assuming constant hazard rates and assuming that the future states of the system are independent of the past states except the immediately preceding one. Computer programs have been developed to perform Markov analysis, and most of the reliability software packages include it as an option [Car97].

### **Reliability Allocation**

Reliability and design engineers must translate overall system performance, including reliability into component performance. Reliability allocation is the process of assigning reliability requirements to the individual parts of the system in order to achieve the overall reliability goal that has been specified. This process can be complex, especially when there is a lack of information concerning important issues such as the role of the component for the functioning of the system, the method of accomplishing this function or the complexity of the component [Kap77].

Most of the basic reliability allocation models are based on the assumption that component failures are independent, the failure of any component results in system failure and that the failure rates of the component are constant. There is a choice of allocation methods. The *equal apportionment technique* assigns equal reliabilities to all the subsystems in order to

achieve a specified level of reliability for the total system. The main drawback of this method is that the subsystem reliability goals are not assigned in accordance with the degree of difficulty associated with meeting them. In the *ARINC method* the assumption is that the subsystems are in series with constant failure rates and the failure rate assigned to each component is based on relative weighting factors that are functions of the past failure rates of the subsystems. *The AGREE allocation method* is more sophisticated than the previous methods. This method is based on component or subsystem complexity and explicitly considers the relationship between component and system failure. The AGREE formula is used to determine the minimum MTBF for each component required to meet the system reliability. It is usually applied in electronic equipment, and is based on assessing the complexity of a component based on the number of modules and circuitry of the component. These are some examples of allocation algorithms that can be used depending on the different circumstances. Reliability software packages usually include one or more of these methods<sup>4</sup>.

## 2.9 Reliability Testing

In modern industry, testing has become an integral part of the engineering product development process. It is the activity responsible for evaluating the design at the earliest stage possible, when failures can be corrected easily and at a minimum expense. Especially in some situations, when developments risks are high, having an integrated test program becomes critical in terms of time and resources. Testing, of course, requires a certain amount of investment, and in some cases, this effort may not pay back in useful results. It is the responsibility of the managerial level, to determine the amount of effort and capital expenditure in the area of testing.

Reliability testing, is the area of testing that concentrates on discovering causes of failure of the component or system, that have been left out in the design analysis. As well as that, reliability testing assesses the damage caused by the failure modes, and tries to determine the parameters or sources of failure. Reliability testing should be considered as a part of an integrated test program that should include statistical tests, functional tests, environmental tests, reliability tests, and when appropriate safety testing [Oco91]. These categories are not completely independent, and a good communication and interaction between them is necessary to minimize the effort and maximize the efficiency of the results.

The basic general requirements for any type of testing activity, and also for the reliability testing are:

---

<sup>4</sup> A brief description on each of the methods listed, is given in appendix 4.

- Complete set of specifications on component design, manufacturing processes, operating conditions, environmental conditions and handling and storage situations.
- Description and requirements for testing equipment and facilities.
- Standards or mandatory regulations on the performance and operation of the component/system. Standards on testing for quality assurance programs.
- Test and failure reporting system, common to all the design activities, and shared by all the product development team.
- Test schedule.

### Planning Reliability Testing

Planning reliability testing involves firstly reviewing all the design analysis techniques that have already been covered in this chapter. Documents and data coming from FMECAs, FTAs, design reviews, environment analysis, etc. must be considered. These should have highlighted the risks and uncertainties in the design and the reliability test program should specifically address these [Bla92].

Analyzing time effects involves looking at the pattern of the main failure modes with respect of time, and deciding whether is cycles, distances, time, on-offs, start-stops, voltage drops, etc. Once the measuring unit has been chosen, then a prediction of what the failure rate behavior is going to be should also be made. This means deciding whether the failure rate is constant, increasing, or decreasing with this time unit. If the failure modes have increasing hazard rates, testing must be directed towards assuring adequate reliability during the expected life. Therefore reliability tests must be of sufficient duration to demonstrate this, or else, they have to be accelerated as will be described later on. The first type of tests is the so-called *endurance tests*, and the second are called *accelerated tests*.

### Endurance Testing

In general all mechanical components and systems are subjected to wear and fatigue, i.e. increasing failure rates. Endurance testing of components or systems, requires running the component continuously, simulating the real operating and environmental conditions, and the purpose of the test is to determine whether the component survives the estimated life or reliability parameter given in the design analysis, or not. The testing parameters, such as environmental and operating conditions, would ideally be monitored, so in case of failure, they can be studied, in order to associate the failure with one of these parameters, and therefore be able to re-design to meet new requirements. Endurance testing is very useful, as it is a real life test, although it has some disadvantages. The main disadvantage being

that the component has to be tested for long periods of time, and it is unlikely that the component is not released for production before the end of the endurance test. Hence, although the failure might be identified, it is sometimes a bit too late. In this case, failure might be already happening on the field, with consequent customer dissatisfaction, and also the cost of re-designing has gone very high, since products are already in production. In summary, although endurance testing of the product is highly desirable to anticipate possible problems, it is not the most efficient type of reliability testing, specially when mean time of components is meant to be high (this is the case of most of the mechanical and electrical components in today's market) [Oco91].

### **Environmental Testing**

Reliability is strongly influenced by time effects, and also by environmental or operating conditions. Therefore the reliability test program must cover the range of environmental conditions, which the product is likely to have to endure. Some of the typical environmental factors affecting most products are temperature, vibration, shock, humidity, power input and output, dirt, people, and in the case of electronic equipment electromagnetic effects, and voltage transients, including static electrical discharge. Certain other environments, can affect reliability in special cases, such as radiation, lubricant age or contamination, high altitude, space vacuum, industrial pollution, electromagnetic pulse, salt-spray, fungus or high intensity noise. Standards have been developed that cover some of the specifications in environmental testing. However, these standards do not address reliability directly, since the objective is to show that the product will not fail or incur damage under the test conditions. Most of these tests do not require the equipment to be operating during the tests, an issue that is critical for reliability testing. As well as this, generally these specifications do not cover combined environmental situations, and are usually single-environment situations.

The environmental aspects of reliability testing must be determined by considering which environmental conditions, singly and in combination with others are likely to be the most critical from the reliability point of view. The best sources of information would be past experience, and literature, or codes or practice.

When past experience or the standard methods available are not appropriate because of the singularity of the product or environment, then the evaluation of the product environment must include the following information:

- For each condition, maximum and minimum values, as well as rate of change of conditions. For example a high rate of change of temperature can cause fracture or fatigue due to thermal mismatch or conductivity effects.
- Operating dormant conditions in relation to outside environments.
- Effect of combined environments might be much more severe than any one condition.
- Direction and modes of vibration and shock.

### **Accelerated Tests**

As discussed in the section of endurance testing, sometimes the products test time necessary to provide adequate reliability assurance under normal operating conditions might be inordinately long, and therefore very expensive. Reliability initiatives, should not hold up development, and should be as economical as practicable, so it is important to be able to accelerate reliability tests.

Accelerated testing should be employed during the development phases of a product, so that changes in design and manufacturing processes can be effected with minimum cost and delay.

Reliability tests can be accelerated by increasing the sample size in the cases where the life distribution does not show a wear out characteristic during the anticipated life. This is appropriate for small, cheap items, which can be produced in quantity such as electronic components or hydraulic seals. However the normal scenario in reliability testing is that components suffer from wearing out processes, and that small samples are preferred, because of economical and practical issues. In this case the accelerated test is provided by increasing the severity of the test. It is then necessary to evaluate the equivalent operating time under normal stress, and analyze whether failure induced under accelerated test conditions are the same as those that might occur under normal conditions.

Unfortunately, not every failure mechanism is accelerated by the same factor for a given stress. If sufficient data for each failure mechanism exist, then each mechanism's accelerating factor may be estimated. Otherwise, combining all the failures for the test process into one group and calculate an average acceleration factor, is the best that can be done.

## **2.10 Reliability In Manufacture**

Once the design is agreed, and released, and the product goes into production, the reliability concerns are dealing with the variability that is inherent in every production process. The major objectives of reliability in the manufacturing area are:



- Controlling and minimizing variability.
- Identifying and solving problems.

However, these initiatives are not exclusively the objectives of the reliability program, but are common to the reliability and quality departments. It is common scenario, that the reliability program is implemented in environments where quality control activities are already in operation and therefore, reliability in manufacture is not one of the newly introduced techniques, but something that is already carried out, and that has to be integrated into the program.

### **Reliability & Quality**

Integration of quality and reliability activities, does not only concern the manufacturing aspects of the life cycle, but all the other aspects, and it is necessary to make efficient use of resources, and to achieve efficiently the objective of delivering a quality product, that will attain high levels of reliability. The approach for this integration varies for different organizations. In some cases, quality departments are given responsibility, and reliability teams are part of QC. In some other situations, reliability is part of the design group, independent from quality, and they collaborate through exchange of information, equipment, resources, and in a teamwork environment [Gra96]. Whatever the situation is, there are a few issues that are important in the integration side:

- Being able to operate a common failure data system.
- Being able to share tools, expertise, and information on the statistical methods used for design of experiments, or analysis of developments.
- Being able to share test equipment and test facilities.

In summary good communication, and ideally a common information system, is the platform for an efficient integration of reliability and quality.

In this context, the techniques that are in charge of controlling production variations are usually carried out by the quality department. They are not initiatives included in the implementation of the reliability plan, and therefore they are out of the scope of this thesis. Some of these activities are as control of production variability, statistical process control, acceptance sampling or manufacturing defect tracking and correction report [Baj83].

## **2.11 Maintenance Strategies**

Most products are maintained during the support phase. Maintenance includes repair when failure occurs, as well as a certain amount of scheduled re-work that prevents failure. The latter is especially relevant in mechanical applications. The maintainability of a system is

clearly governed by the design, which determines features such as accessibility, ease of test and diagnosis and requirements for preventive maintenance actions. . Maintained systems may be subject to corrective and preventive maintenance. Corrective maintenance includes all action to return a system from a failed to an operating or available state. The amount of corrective maintenance is therefore determined by reliability [Oco91]. Corrective maintenance cannot be planned. Preventive maintenance seeks to retain the system in an operational or available state by preventing failures from occurring, through scheduled tasks such as inspection, servicing or lubrication. Preventive maintenance affects reliability directly.

### **Preventive Maintenance Strategies**

The effectiveness and economy of preventive maintenance can be maximized by taking account of the time-to-failure distributions of the maintained parts and the failure rate trend of the system. If a part has a decreasing hazard rate, any replacement will increase the probability of failure. If the hazard rate is constant, replacement will make no difference to the failure probability. If a part has an increasing hazard rate, then scheduled replacement at any time will in theory improve reliability of the system. Therefore in order to optimize preventive maintenance, it is necessary to know the following for each part:

- The time-to-failure distribution parameters for the main failure modes.
- The effects of all failure modes.
- The cost of failure.
- The cost of scheduled replacement.
- The likely effect of maintenance on reliability.

Therefore preventive maintenance is not a separate activity from the reliability program, despite the fact that it is usually carried out by resources external to the organization. Preventive maintenance requires integration with the program, in order to feed from the information required. It is responsibility of the organization, to assist in guidance of preventive maintenance strategies, with the documents, information and tools adequate.

Particularly FMECA and FTA are important sources of information for maintenance planning, maintainability analysis and for preparation of diagnostic procedures and checklists. FMECA documents can help in assessing failure modes, costs, safety implications and detectability. The likely causes of failure symptoms can be traced back using the FMECA results together with FTA documents [Oco91].

## **Design for Maintainability**

Focus on design is important when systems are to be maintained. Design must allow for ease of access and handling, for use of standard tools and equipment, and eliminate need for delicate adjustment, so that maintenance tasks are easily performed. In this case, reliability does not suffer from degradation through maintenance and repair, and the maintenance costs are not too high.

Design rules and checklists should include guidance, based on experience of the relevant systems, to aid design for maintainability and to guide design review teams. Apart from general best-practice knowledge on this issue, it is highly desirable to feed back as much information as possible from the maintenance operations, including costs, description of failure modes and symptoms, and any remarks or comments from the operator's in charge of maintenance.

## **Managing Maintenance through backlog**

Managing maintenance is necessary to manage reliability. Managing maintenance can be done in much the same way as managing production. The same way that operations uses manufacturing resource planners, maintenance can use a computerized system to assist in the process of maintenance and to capture and store all the information valuable for making decisions in present or future. This is what is called a backlog system.

The work management process consists of a number of key steps: work identification, work planning, work scheduling, work accomplishment, work documentation and work analysis and measurement. Reliability comes at two levels: equipment and human. Through an effective work management process, human reliability is achieved. That is to say that the process is defined and followed, the teamwork among departments exists, people are held accountable and there is a continuous effort to solve problems. Backlog management contributed to lowest-cost reliability ensuring the right work is getting done at the right time and the right resources. It also contributed to problem solving, and it captures lots of valuable information that is fed back to the organization in order to improve design, maintainability and costing tools.

## **2.12 Failure Analysis, Root Cause and Corrective Action**

Failure of the product, of assemblies or components, occurs all through the life cycle of the product. It occurs during testing, during production, and in the field, once the product has been marketed. It is extremely important to be aware of the existence of these failures, and to be able to have sufficient information as to determine the causes of failure, and the

probability of further problems due to the same causes. As it has been already pointed out in this thesis, the reliability effort should focus on the development and design stage, because it is then, when the changes in the product can be implemented with less waste of money and effort. However, it is not realistic to assume that the design effort is going to be in control of all the parameters, operating conditions and environments. There are always a number of aspects that have been missed in the design process, and that result in failures after design is released. Although this is not the ideal situation, it definitely is the real world, and the reliability program has to cater for this, providing a system of failure analysis, root cause and corrective action, that will quickly and efficiently deal with these failures, solve them, and extract as much information from them as possible for further reference.

The major aspects to be considered for a good failure analysis system are [Gra96]:

- Organization. Definition of the group of people/department or team that is taking responsibility of the failure analysis system. It needs to have authority and clear reporting team.
- Process of failure analysis/ root cause. Definition of a process and supporting structure for analyzing the failures, and discovering the root causes.
- Implementation of corrective actions. Definition of a process and supporting structure for taking effective corrective action to eliminate the root cause, and to check the efficiency of these actions. Good documentation is part of the corrective actions.

### **Failure Analysis Team**

A group of people, department or team, has to be appointed as the failure analysis team, as a part of the organization of the system. Generally this team has to be trained, together with other employees that might be involved in this activity, and has to be given the appropriate tools, meaning information structures, and also laboratories or equipment. Ideally, the failure analysis team should consist of a group of people coming from different areas, such as reliability, design, production and quality. After the necessary training, the team should have good knowledge and understanding of the physics of failure, specially those more related to the particular product. The team should also be given an information structure, so that they can easily retrieve specifications, documents, design analysis information and any other source of data that they need in their activity.

### **Failure Analysis-Corrective Action Process**

Generally, the failure analysis-corrective action process should consist of the following steps:

1. Information of failure is fed back to the team
2. Failures are prioritized and ranked. Criticality, and economically issues are considered.
3. Decision is taken to work in a certain failure.
4. The team performs a root-cause analysis, and suggests a corrective action.
5. The corrective actions are implemented.
6. Information of situation after corrective actions are implemented is fed back to the team to make sure that no further failure occurs.

### **2.13 Structure for the Reliability Program**

All the methodologies and techniques reviewed in this chapter are components of a structure that supports the reliability program. For efficient operation of this structure it is necessary to guarantee the three following requirements:

- The components are well specified, designed and implemented.
- The components are positioned appropriately in the overall structure.
- There is interaction and flow of information and resources between all the components.

All the methodologies and techniques described in this chapter need to be well understood, to be carried out through efficient systems and to be supported with training, reference material, software packages or any other tool that might help in the analytical processes described. The components need to have a well specified location in the overall structure. Because of the large time span of the reliability program plan, it is necessary to outline what is done and when for every methodology covered above. Because improving reliability is an iterative process, iterative loops must be specified and provided for. An outline of this general structure is given in figure 2.4. Interaction between the different methodologies must be supported, through available and exchangeable information. The reliability program expands on time, and different people are involved at different phases. This interaction is best supported with a unique reliability management structure, in the form of a computerized system that encompasses all methodologies, outputs and reports into a common working environment, as will be described in chapter three.



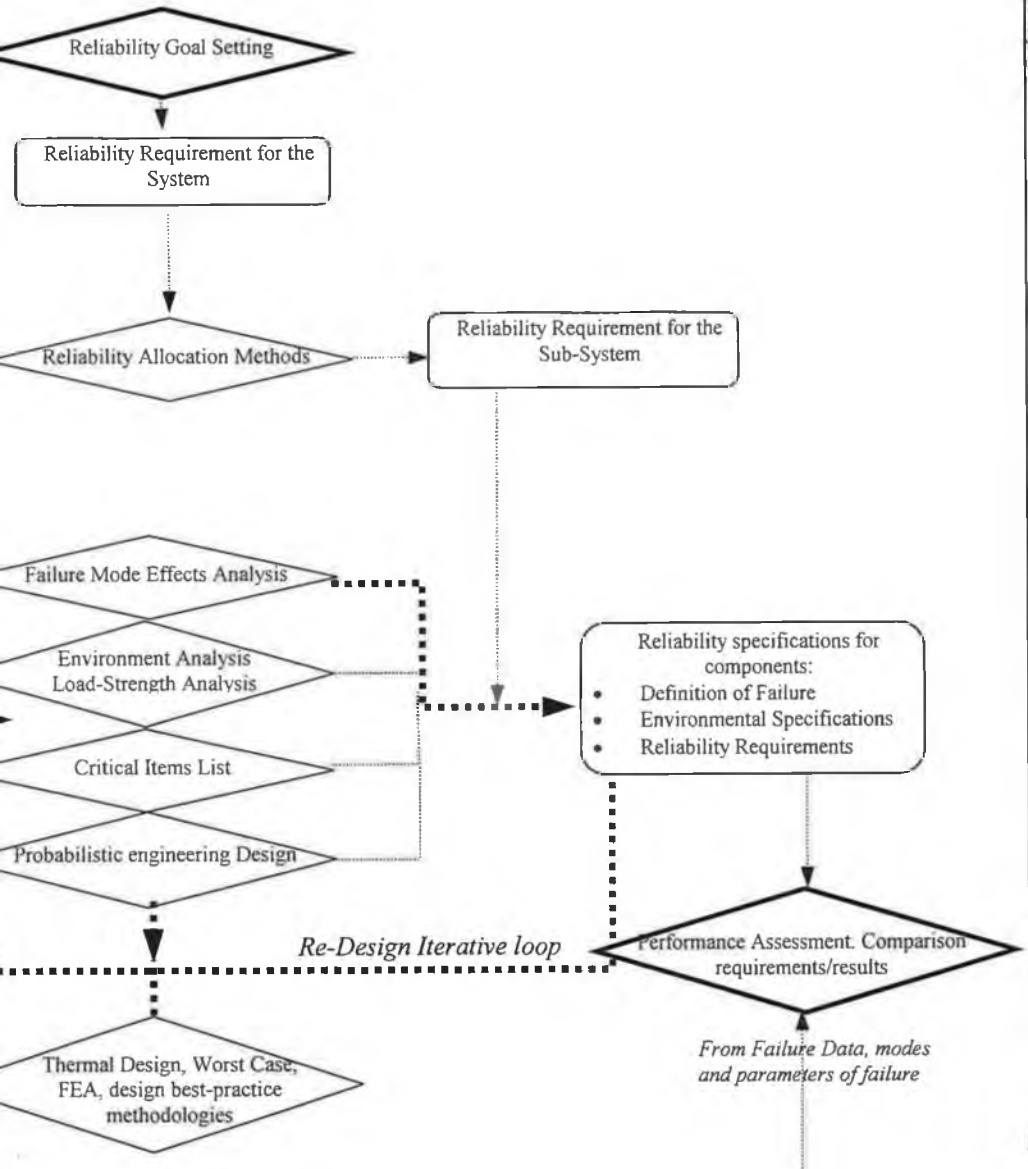

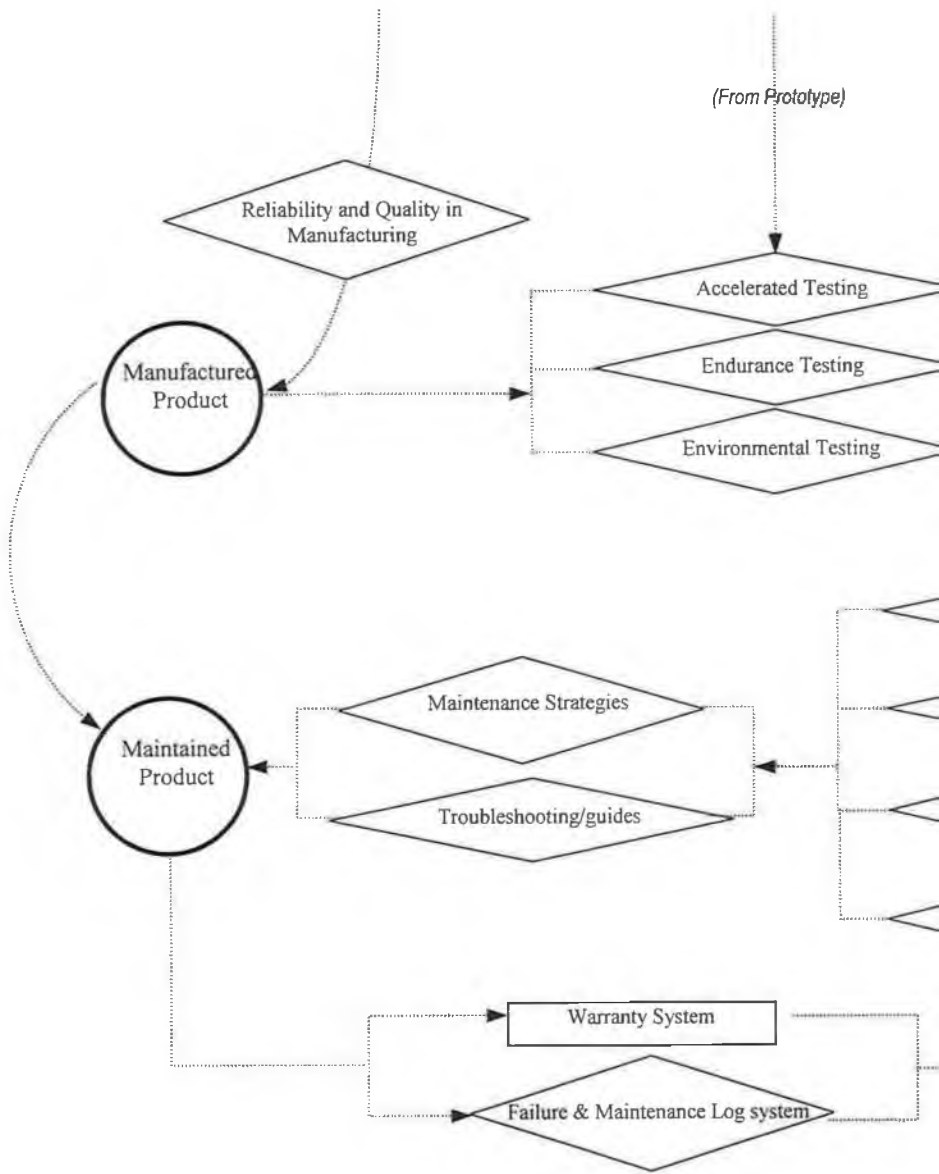
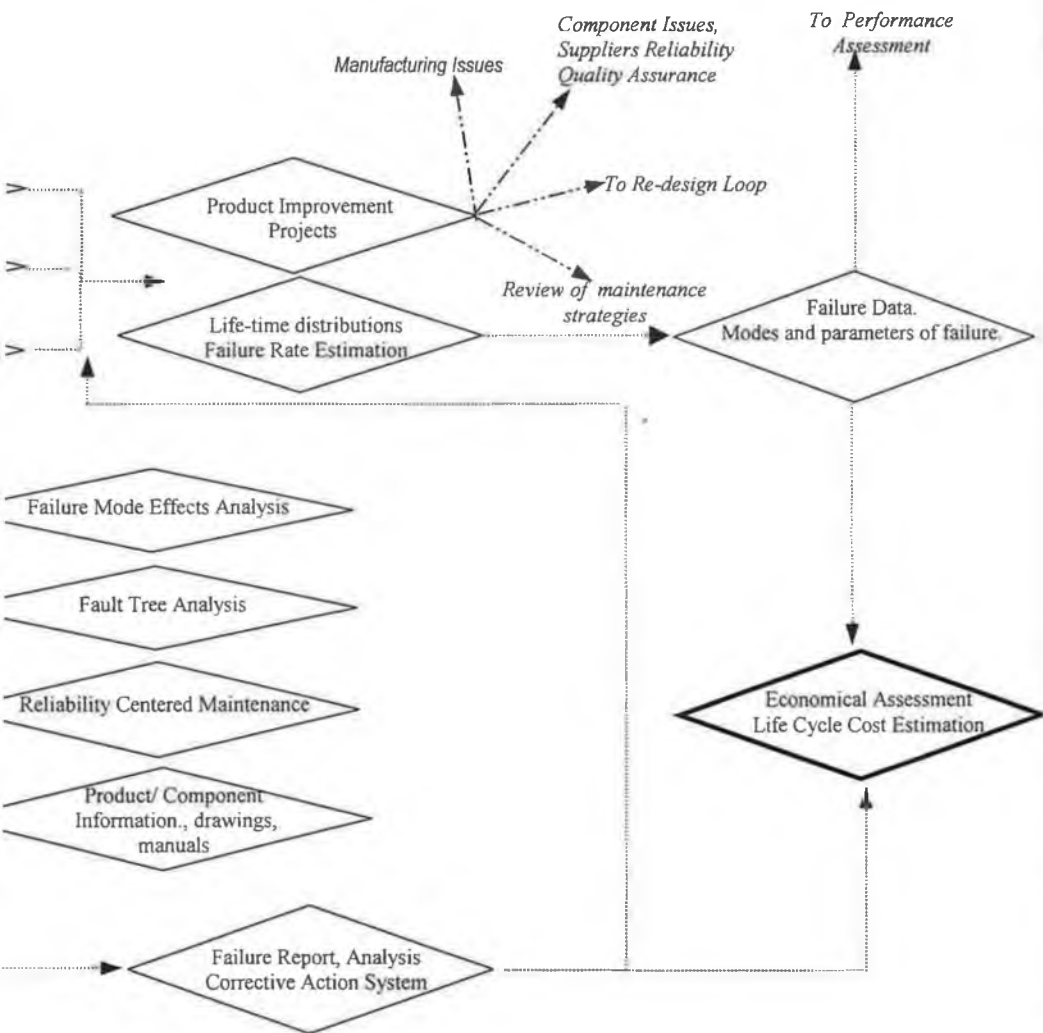

Figure 2.4 Structure of the Reliability Program Plan.





## 2.14 Summary

Producing reliable products has become a major competitive advantage in today's market environment. A reliable product will satisfy the customers, will cause low cost in warranty and repairs and will build product reputation. A model has been presented that implements a reliability approach in the form of a process, with a set of inputs and outputs, tied to the product development process, from design to retirement. This process includes three major aspects: *management issues, program initiatives, and information management*. Managing the program involves setting goals, assessing the economics of it, and allocating the reliability initiatives to the right personnel. Procedures for setting goals, and examples of reliability goals and requirements have been presented. The economics of the plan are assessed through costing reliability and cost unreliability.

The program initiatives have been structured in eight different areas: *Supplier Reliability and Quality Assurance, Design for Reliability, Statistical methods and models in Reliability, Reliability in Manufacture, Reliability Testing, Failure Analysis-Root Cause and Corrective Action Systems, and Maintenance Strategies*. Implementing these methodologies and procedures results in an approach that takes reliability considerations all throughout the life cycle of the product. Some of the most important methodologies have been reviewed.

An efficient reliability program requires a system that integrates all of these methodologies and that provides a framework for efficient operation of the program. This system takes the form of a computerized information system. A list of the requirements for the system, together with the review of some of the software packages available, and the selection of a solution, is given in chapter three.

# Chapter 3

## Information Systems for the Reliability Program

3.1 Introduction

3.2 Requirements for the Reliability Management Information System

3.3 Benchmarking of Reliability Software Tools

3.4 Product Data Management Systems

3.5 Summary

### 3.1. Introduction

Chapter two has reviewed the methodologies and initiatives that drive the organization towards delivering reliable products. In the context of a reliability program, the remaining issue is the implementation of an information system that supports the program and that encompasses the reliability activity with all the other aspects of the organization.

This chapter will start outlining the requirements of this system. A brief discussion of the different solutions available will then be presented including a review of some of the reliability software packages available in the market. *Product Data Management*, PDM, systems (which are being implemented successfully in other aspects of the engineering activity), will also be considered. The advantages, disadvantages, deficiencies and benefits from these packages will be examined in the form of a benchmarking exercise. As a result of this, PDM systems will be then presented as the most suitable framework for the reliability program. These systems will be described in detail. The need for completing these systems with other available tools will also be discussed at the end of this chapter.

### 3.2 Requirements for the Reliability Management Information System

Reliability is an engineering activity with a life cycle approach. It consists of methodologies applied at different stages by different people. An integrated approach towards reliability requires a system to support, communicate, exchange, analyse and store information.

The requirements for the system that would support most efficiently the reliability program previously presented, lie in two different categories, i.e. *analytical capabilities* and *efficiency/integration requirements*.

### Analytical Capabilities

An information system can be defined technically as a set of interrelated components that support and deal with the information that organizations need for making decisions, controlling operations, analysing problems and creating new products or services [Lau00]. For the purpose of the reliability program, the information system will have to deal with reliability issues and therefore provide the users with a set of appropriate tools. The analytical capabilities of the system refer to the functionality of these tools, i.e. a module for performing fault tree analysis, a package that automates life data analysis, or a template for convenient failure reporting. Ideally the information system should provide tools to support every aspect of the reliability program. In reality, the system will incorporate some of these capabilities, but will be flexible as to integrate others as the user decides it. Some of the methodologies and activities that the system should cater for are given in table 3.1.

<b>Analytical Requirements</b>
Establishing Reliability Requirements
Life Cycle Cost Estimation
Product & Supplier Evaluation
Incoming Inspection
Vendor Rating
Environmental Analysis
Load-Strength Analysis
Failure Modes and Effect Analysis
Fault Tree Analysis
Design Reviews
Critical Items List
Thermal Design
Worst-Case Analysis
Parameter Estimation
Probabilistic Engineering Design
Reliability Block Diagrams
Reliability predictions (mechanical models)
Pareto Analysis
Markov Analysis
Monte Carlo Simulation
Reliability Growth Tracking
Reliability Allocation Methods
Testing management
Failure Report and Corrective Action System
Maintenance Backlog
Reliability Centered Maintenance
Troubleshooting Support

Table 3.1 Analytical requirements of the reliability information system.

### Efficiency/Integration Requirements

Companies today operate in a global market, interacting with teams, customers and suppliers all over the world. Teamwork has been greatly enhanced, and product development processes have been revolutionized with concurrent engineering techniques. Managing information and maximizing the knowledge resources becomes critical in the era of information economy. In summary, while tool functionality is obviously important, if the system does not integrate in the engineering and organizational environment, it will never be fully used or cost effective. A list of requirements for the reliability information system that will guarantee its efficiency and integration is given in table 3.2.

Efficiency/Integration requirements	Features to comply with the specified requirements
Support well-designed and implemented methodologies.	Provide guidelines, checklists, and procedures for the different methodologies. Use and Integration of software tools that support the methodologies used. Provides standard data system, and templates User-friendly environment.
Support integration of methodologies within the system	Data storage. Single/common data reservoir that serves all the modules. Information sharing. Communication between tools being used. Possibility of data import/export.
System integrated in organizational information structure	Enterprise wide solution. Communicate/import/export data with other enterprise information systems. Integrate/communicate with other tools, specially standard tools used such as office automation, and Cad packages.
Supports exchange of information across supply chain, and direct interaction with customers	Web utilization Supplier's/customer's functionality considered in the data structure and involved in the analysis.
Supports engineering activity	Facilitate teamwork and concurrent engineering Facilitate research and consultancy, providing libraries, standards, and web integration. Provides right data at hand. Automates flows of information and data to relevant team members. Graphical and tabular reporting capabilities. Supports product tree, bill of materials structure..
Supports knowledge management	Stores information for further reference in a meaningful standard form. Knowledge builder capabilities.
Supports managerial activity	Project management and planning capabilities. Customized report structure, for decision making processes. Program assessment tools, both performance, and economical.
Supports security and consistency	Different levels of access to different levels of information Secured data reservoir. Automation of signed-offs, approvals and check-in processes. Facilitate information iteration, keeping track of changes made, by whom and when. Revision system.
Customization tools	Possibility to design new tools and operations within the system Integration with applications development packages. Possibility to design new processes and flow of information within the system
Searching and retrieving capabilities	Classification of data structure and documents, that supports querying systems by attribute, types, etc.

Table 3.2 Efficiency/Integration requirements of the reliability information system.

### 3.3 Benchmarking of Reliability Software Tools

The requirements for the information system that will manage and support the reliability program have been outlined in the last section. These requirements will decide upon the different solutions that initially, seem to support reliability activities in a company. Although a certain level of customisation will always be necessary for the software to comply with specifications, the following benchmarking exercise will try to determine the most suitable package i.e. the one that provides the required features in its most generic form, and requires therefore, fewer adjustments to operate.

#### Reliability Software Packages

There are a growing number of reliability software solutions designed to support reliability programs. The providers of these packages vary in their motivation and market focus. Firstly there are a number of consultancy firms that offer training and support in reliability program implementations, and have developed their own software packages to assist these implementations. These firms can offer off-the-shelf solutions or the possibility of fully developing and customizing a solution for the particular needs of their clients.

Secondly, software companies specialized in computer aided engineering issues, have designed different packages for reliability and maintainability analysis. They usually offer modular design, with tools that can be implemented separately but that fully integrate within the system. Finally a number of companies offer specialized solutions in a certain area of expertise, such as hazard studies, plant reliability, computerized maintenance and logistics systems, or safety and environmental assessments.

For the purpose of this thesis, a representative sample of packages that is not specific to one area has been selected. A review of these packages, together with a brief outline of its major characteristics is given next.

**Support system Corporation, SSTC.** This organization is focused on mechanical engineering applications. They offer a range of training and support literature in reliability, maintainability, troubleshooting, testing, etc. Their software package for reliability analysis is called *MechRel*. It is basically a model generator, which uses a range of libraries and standards, and reliability block diagrams to calculate life estimations for mechanical engineering components. They also offer the use of microchip tag applications for maintenance and troubleshooting assistance [SST00].

**Relex Software.** *Relex* provides a very complete set of modules for reliability and maintainability analysis. It focuses on the importance of providing component and part libraries and standards. It provides an *SQL* library browser and search engine. It offers

integration with software packages commonly used in an engineering environment, as well as with application development packages. It is a standard package that offers more than a well-designed suite of tools. It has a holistic view of the reliability process, and although it misses some of the integration/communication/teamwork requirements, it shows a further concern than just providing analytical solutions [Relex00].

**ReliaSoft.** *Reliasoft* corporation consists of four integrated business units, *Standard Software, Enterprise Solutions, Infrastructure Enabling Technologies* and *Consulting, Education, Research & Training*. The standard software packages are modules designed to carry out specific reliability tasks, mostly in the statistical domain. From developing these software packages, *ReliaSoft* has moved onto consultancy services in developing reliability systems customized to client. In this field *ReliaSoft* aims to automate the entire process of data acquisition, analysis and reporting in standard database architecture. For the purpose of this thesis, only the standard software packages have been benchmarked [Relia00].

**Meadep.** *Meadep* offers a four-module solution. The first module is called *data pre-processor*. Its purpose is getting data from files or databases through import/export utilities. The second module is the *editor-analyzer* and it consists of a parameter estimation tool that generates values to feed the third module, which is the *model generator*. The model generator is a reliability block diagram engine. The software seems to be orientated for engineers with an in depth knowledge on reliability simulation, especially for plant engineering and digital/electronic components. It is more a specific tool than an integrated solution for reliability engineers [SoH00].

**Item Software.** For years *Item Software*, was the official distributor of *IsoGraph* products, a modular set of tools that covered most of the well-used reliability techniques. However, this is not the case anymore, and *Item Software* offers now a new range of products, centralized in their *Item Toolkit*. This package includes the most popular tools in an integrated environment. Although *Item* stresses their user friendliness, demos are not available, and the software could not be properly evaluated [Ite00].

**IsoGraph Direct.** *Isograph* has offered for years a set of modules through their distributors *Item Software*. These included reliability centered maintenance, availability calculations, fault tree analysis and others. Traditionally they focused on the analytical capabilities, and only recently they are implementing solutions that would suit better the new engineering environment. This shows in their new product, the reliability workbench, with a more comprehensive view of the reliability process, and further integrations [Iso00].

**BQR Engineers, Care Software.** *CARE, Computer Aided Reliability Engineering* is a very complete package that has resulted from the consultancy experience of *BQR*

*Reliability Engineers*, over the years. The aim of *Care software* is integrating reliability software into the engineering CAE tools, to support reliability in an efficient manner. The tools purpose it to serve reliability engineers but also designers, managers and marketing personnel concurrently. It stresses the need for single database, data sharing and data communication. It also considers integration issues. It is one of the most comprehensive packages in the market [BQR00].

**Raytheon, ASENT, CARMA.** *Raytheon Systems Company* has worked for years in the development of computer aided engineering tools. Their *Computer Aided Reliability and Maintainability Applications toolkit*, CARMA, is designed to address the demanding needs of the reliability and maintainability engineering, not only as in tool functionality but also in computing/working environment. This toolkit a large offer of features, such as integration, tool development, data conversion, or web technologies for the six-module package, that covers most of the reliability related activities [Ray00].

**Fractal Solutions.** The focus of this company's software is reliability centered maintenance, and its application in plan engineering. However it offers a comprehensive and integrated package that provides functional tools, together with security, integration, knowledge builder, etc. It is a truly enterprise wide solution in its area of specialization [Frac00].

**AAC, Advance Reliability Technologies.** AAC is a re-seller of different software packages. Their offer includes quality tools, such as *Taguchi method*, and reliability analyses. The latest is a six-module package, that cover different aspects of the product life cycle, stressing functionality of the tools, over requirements such as integration with other software and systems, or data templates and structures. One unusual feature of this package is that it provides a security/access authorization system [Dre00].

**ABS Group, JBF Associates.** JBFA is the reliability & risk division of the ABS group. They are a consultancy group focused on carrying out hazard analysis and risk assessments based on a range of different methodologies. They also assist in program implementations, from reliability to maintenance and logistics. In the area of software they have developed a set of modules that assist their operations and program implementations. This software is therefore orientated towards safety and risk analysis methodologies. Although they have their own models and processes in reliability program implementations, they do not present any software framework supporting these implementations [ABS00].

**EngineeredSoftware.** This package, called *Reliability & Maintenance Analyst* is a simple, user friendly tool that performs data analysis, parameter calculation and maintenance



optimization. It is not intended to support other methodologies or to serve as any other purpose than the functionality of its features [Eng00].

**Reliability Analysis Center, PRISM Software.** The *Reliability Analysis Center* is an initiative from the *American Department of Defense*. RAC offers a complete product line of reliability, maintainability, quality and supportability publications, automated databases and software. *PRISM* is the new RAC software tool that ties together several tools into a comprehensive system reliability prediction methodology. This package stresses out the standards and libraries, where the department of Defense has extensive experience [RAC00].

**Product Data Management Systems.** A number of companies offer relational databases with different fronts to operate them, as a global solution for the reliability information issue. This concept is known commercially as product data management systems. These systems are relational databases that give structure to the meta-data, and can operate different data sources. Their features and capabilities comply with all the requirements listed above. The companies involved in reliability work, offer their own solution that is customized to the needs of the organization in the field of reliability. However, there is a huge range of product data management systems in the market that can be implemented and customized in-house, or as a part of a larger project that develops a system to support all the engineering activity, reliability being a part of this large implementation. Therefore product data management systems have been considered as candidates for building the reliability information system.

### **Assessment of the Reliability Software Packages**

The requirements for the information system that would support the reliability program, have been divided in two categories. Firstly, the capability of the system to support all the methodologies reviewed in chapter two, and to automate or facilitate the work of the engineers in performing them. Secondly, a number of other requirements that will result in an efficient system, which supports the actual engineering environment and integrates in the organizational overall system. In table 3.3 the software packages that have been presented are assessed as to support functional tools. In table 3.4, the assessment looks at the other requirements that have been listed before. In each table the packages are sorted from less suited to more suited to the requirements that are looked at.

Troubleshooting support		✓			✓				✓		✓	✓
Reliability Centered Maintenance	✓	✓		✓	✓	✓	✓	✓	✓	✓	✓	✓
Maintenance Backlog				✓					✓		✓	✓
FRACAS		✓		✓							✓	✓
Testing				✓						✓	✓	✓
Reliability Allocation Methods				✓		✓		✓			✓	✓
Reliability Growth Tracking				✓							✓	✓
Pareto Analysis							✓				✓	✓
Monte Carlo Simulation						✓		✓	✓		✓	✓
Markov Analysis			✓			✓	✓	✓			✓	✓
Reliability Block Diagrams			✓	✓		✓	✓	✓	✓	✓	✓	✓
Use of Relia Standards (Bellcore, Mil, ..)			✓		✓	✓	✓	✓	✓	✓	✓	✓
Reliability Prediction based in mech. models			✓			✓	✓		✓	✓	✓	✓
Probabilistic Engineering Design										✓		
Parameter Estimation	✓		✓	✓				✓	✓	✓	✓	✓
Worst-Case analysis									✓	✓		
Thermal Design									✓	✓		
Critical Items List											✓	
Design Reviews												
Fault Tree Analysis		✓				✓	✓	✓	✓		✓	✓
FMECA					✓		✓	✓	✓	✓	✓	✓
Load-Strength Analysis									✓	✓		✓
Environmental analysis									✓	✓		✓
Vendor Rating												
Incoming Inspection												
Product & Supplier Evaluation												
Life Cycle Costs								✓	✓		✓	✓
Reliability Requirements										✓		✓
	EngineeredSoftware											
	ABS, JBFA Group											
	Meadep											
	ReliaSoft											
	Fractal Solutions											
	RAC, PRISM											
	Item Software											
	IsoGraph											
	Relex Software											
	Support Systems Corporation MechRel											
	Raytheon, CARMA										✓	
	AAC										✓	
	BQR Care											✓

Table 3.3 Comparison of analytical requirements for reliability software packages.

Supports product tree structure and BOM	✓		✓	✓	✓	✓	✓		✓	✓	✓	✓	✓	✓
Knowledge builder capabilities (capture different information in the form of templates)														✓
Possibility of building up own libraries				✓		✓			✓	✓	✓	✓	✓	✓
Provides libraries, standards	✓	✓		✓		✓		✓	✓	✓	✓	✓	✓	✓
Flexible and efficient classification of data structure and documents														✓
Integration with application development packages									✓					✓
Possibility to design new tools and operations within the system														✓
Facilitates information iteration, keeping track of revisions													✓	✓
Supports security and consistency												✓	✓	✓
Graphical and tabular reporting	✓	✓	✓	✓	✓	✓	✓	✓	✓	✓	✓	✓	✓	✓
Customized report structure capabilities					✓	✓	✓	✓	✓	✓	✓	✓	✓	✓
Project planning /management capabilities											✓	✓	✓	✓
Automates flow of information														✓
Facilitate teamwork and concurrent engineering		✓									✓	✓	✓	✓
Supplier's/customer/s functionality considered in data structures														✓
Web enabling capabilities												✓		✓
Possibility of Import/Exp-ort Data		✓	✓		✓	✓	✓	✓	✓	✓	✓	✓	✓	✓
Possibility of integration with office packages (work, excel, access...)			✓				✓	✓	✓	✓	✓	✓	✓	✓
Possibility of integration with CAD/CAE packages								✓	✓	✓	✓	✓	✓	✓
Enterprise Wide Solution												?	✓	✓
Single/Common data reservoir for all modules	✓	✓	✓	✓	✓			✓	✓	✓	✓	✓	✓	✓
Modular design	✓	✓	✓	✓	✓	✓	✓	✓	✓	✓	✓	✓	✓	✓
User friendly environment		?		?	✓		✓		✓	✓	?	✓	✓	✓
	Support Systems Corporation MechRel	ABS, JBFA Group	Meadep	Item Software	EngineeredSoftware	AAC	ReliaSoft	IsoGraph	RAC, PRISM	Relex Software	BQR, CARE	Raytheon, CARMA	Fractal Solutions	Customized Product Data Management system

Table 3.4 Comparison of efficiency/integration requirements for the reliability software packages and product data management systems.

The results of the assessment can be summarized as follows:

- Traditionally, reliability software packages focused on providing tools for performing certain types of reliability and maintainability analysis, such as parameter estimation, or reliability centered maintenance. Their approach to reliability was simplistic and did not take into consideration the life cycle of the product. Although these packages can be useful tools for reliability engineers, they cannot serve as an information system for the reliability program, and do not support reliability planning and management.
- In recent years, some of these packages have been developed further. These days, reliability software packages tend to offer a modular design, offering a flexible structure that allows the engineer to choose from a broad range of tools. It has also been recognized the need to manage information, to integrate these packages in the CAE environment, and in the organizational structure.
- After the assessment of all the packages available, it is concluded that higher importance must be placed in providing integration, flexibility, communications, knowledge management and security. If the reliability system is configured to cater for those, and it is flexible enough, the functional tools can be built upon the system. On the contrary a system focused on providing analytical capabilities, will not allow for management of information, integration of the system, or further developments. In summary the information system must provide a foundation for the program to be built on, rather than blocks that cover bits and pieces, but do not form an overall structure.
- There is no off-the-shelf package that covers all the range of requirements that have been specified for the reliability program implementation, either in functional tools or in integration requirements. The solutions that come closer to the specified requirements are the customized pieces of software that the consultants in reliability offer to clients. These solutions take the form of relational databases, with tools developed to manage the data. Their principle is the same as the data management systems that have been implemented in other areas of the engineering activity.
- Product Data Management Systems offer full capabilities and features for building the information system. Although their structure has to be customized, and the templates and tools have to be developed, these systems offer the flexibility, and level of integration required.

### 3.4 Product Data Management Systems

Product Data Management Systems, have become very popular in the last four or five years. They have been developed to cover a gap in the information structure of an organization that left the engineering activity, isolated from manufacturing, from purchasing and from the general operation. Managing information has become critical, and supporting its exchange and flow is a key issue for the company's success. This section will describe PDM systems generically. It will outline their major characteristics and features, their components and their benefits to the organization. It will also discuss the situation of the PDM systems within the other major enterprise wide information systems, i.e. Enterprise Resource Planners, ERP and Material Resource Planners, MRP. Finally the implementation of a product data management system in the context of reliability program and management will be reviewed.

#### What is a PDM System?

A Product Data Management system is a tool that helps engineers, designers and product managers to manage the life cycle of the product, in both data and processes. It encompasses many different aspects, such as *engineering data management* (EDM), *product information management* (PIM), *technical information management* (TIM), *workflow/groupware* (WF) or *image management* into a unique system that tracks the data and information needed to design, manufacture, support and maintain a product. It is also cross-departmental since the potential users of a PDM system go from project management and manufacturing to quality assurance, sales or purchasing. The early systems were developed with a manufacturing focus. Key engineering process capabilities of these systems were *release management* and *change management*. In recent years other areas of the product life cycle have been targeted for improvement. Today a PDM system is a very valuable tool to support concurrent engineering practices, by allowing different teams to work in the same projects while assuring security, revision control, and consistency. They also deliver industry-business solutions that support compliance with industry and regulatory standards, and provide pre-defined standard reports, as well as fully integrated applications to support activities such as logistics and field service, software development and project management [Tsa93]. Figure 3.1 shows the position of the PDM in the context of the organization.

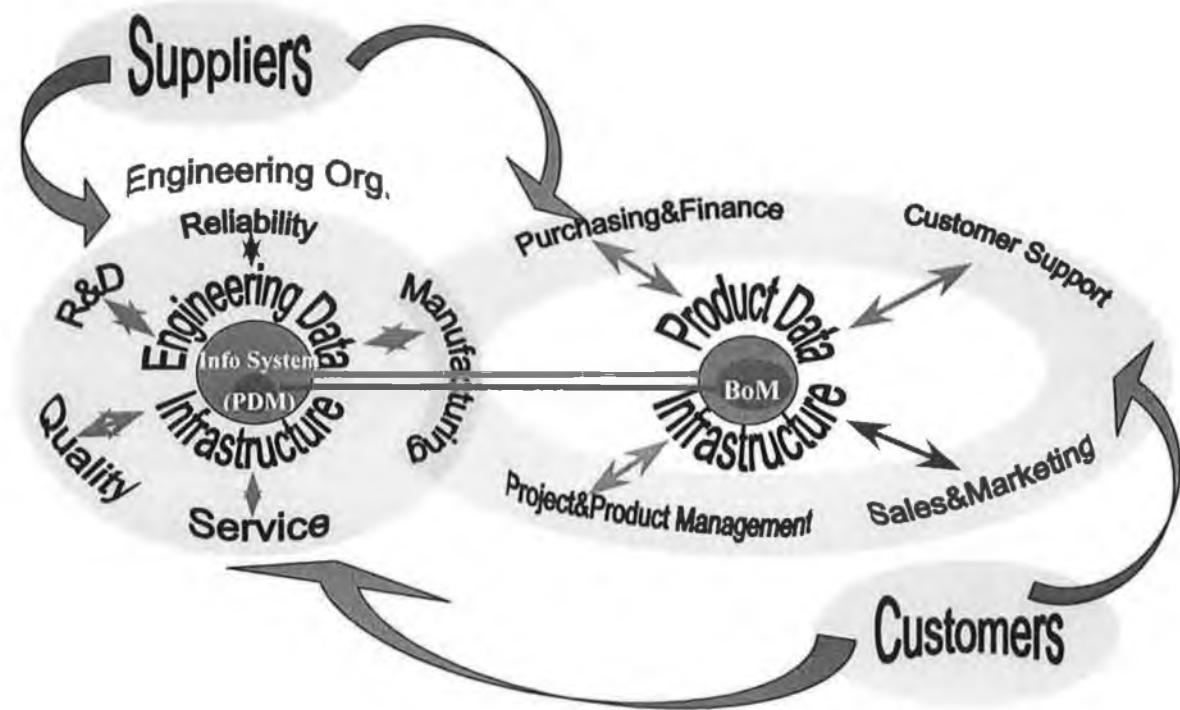

Figure 3.1 Product Data Management in the Organization.

### Product Data Management (PDM), Manufacturing Resource Planning (MRP) and Enterprise Resource Planner (ERP)

The three enterprise wide solutions for information management today are enterprise resource planner, ERP, manufacturing/materials resource planning, MRP and product data management, PDM. There is a certain degree of overlap between their scope, and a lot of discussion about the similarities and differences between them. Historically, MRP's were the first to be developed [Bou00]. This acronym originally stood for materials requirements planning, and it consisted on matching orders levels of raw materials with predicted final product shipments. These systems have evolved into today large suites of software which calculate resource-limited schedules, manage change control of product configuration, allow for future planned changes in product and resources as well as including full financial and stock control functions. Enterprise Resource Planners are systems that manage the entire spectrum of the enterprise operation, not only the manufacturing/inventory aspect that the MRP covers. The ERP includes contract management, production, procurement, cost accounting and finance. The flow of information concentrates on logistics data [Sar00].

Finally PDM's are systems to manage all forms of product related data throughout a product's life cycle. They serve mainly designers and engineers and concentrate on engineering data about the parts and the product.

Because there is a certain level of overlap between the functionality of these three systems large manufacturing companies today, implement them as modules of the unified information system. Integration and communication between them is a major issue. Each organization has to consider its needs for information, and for structures and implement a system that suits these needs.

### Components of a PDM System

As described before, the PDM system supports management of the product life cycle. In order to do so, a PDM system has the following features and capabilities [HP99]:

- Electronic data storage and management.
- Classification of component/documents and product structure.
- Flexible File organization, and support of multiple file formats.
- Querying and viewing capabilities.
- Document security and access levels to information.
- Timely controlled access to information.
- Workflow automation.
- Customisation tools and integrated solutions.

These features are met by the system through a number of elements in their architecture, i.e. *data vault and document management, product structure management, classification and retrieval, workflow and process management, program management and control, utility functions and integration functions.*

**Data vault and document Management.** This provides a physical storage system for the data and documents, with security levels and controlled access. It usually involves establishment of data inter-relationships and life cycle management of data, by defining states such as checked in, checked out, revision, etc.

**Product Structure Management.** Provides the capability of structuring the data as a part list or bill of materials, with part definitions, attributes and links. The querying capabilities of the PDM systems make different view of the data possible.

**Classification and Retrieval.** Information and data is not only efficiently stored, but it can also be efficiently retrieved. The system provides tools to search for parts, attributes, codes, structures, types of documents, free-text searches, etc.

**Workflow and process management.** Specifies process definition, revision and version relationships and control. It establishes automated workflow paths, and automated flow of

information along pre-defined nodes. It manages approval and signing of parts and documents, so that information stored is consistent and reliable.

**Program management and control.** By process management, and by creating breakdown structures and schedules.

**Utility Functions.** Communication and notification, that handles e-mail and notes. Data transport among users and systems. Image services, that provide viewing capability for documents, so that they can be viewed by users that do not have supporting software. Some systems also provide red-line markup capability in their viewing tools.

**Integration Functions.** Data translation, means that the system can have tools to translate data among different systems, CAD, CAM, ERP's etc. It also has administration set-up control, so that system can be customized and maintained.

All of these components are more or less common to every product data management solution that is available in the market

### **Benefits of Implementing a PDM System**

Some of the benefits of implementing a PDM System are:

- Reduced time to Market.

A PDM System can speed up tasks by making data instantly available as it is needed. It supports concurrent task management, and it allows authorized team member access to all relevant data with the assurance that it is always the latest version.

- Improved design productivity.

Historically a design engineer would spend as much as 25-30% of his time simply handling information, looking for it, retrieving it, waiting for copies or archiving new data. PDM removes this dead time almost entirely. It also avoids duplication of efforts, and saves the amount of time designers spend solving problems that have probably been solve before, but where the solution can not be found or retrieved.

- Improved Design and Manufacturing Accuracy.

The PDM assures that everyone in a project is operating on the same set of data which is always up to date. Overlapping or inconsistent designs are eliminated.

- Better Use of Creative Team Skills.

Designers are often conservative in their approach to problem solving for no other reason than the time penalties for exploring alternative solutions are so high. PDM helps by keeping track of all documents and test results relating to a given product change, minimizing design rework and potential design mistakes. It reduces the risk of failure by sharing the risk with others and by making the data available to the right people fast.



- Comfortable to Use.

Although PDM systems vary widely in their levels of user-friendliness, most set out to operate within the existing organizational structure of a product engineering operation, without major disruption.

- Data Integrity Safeguarded.

The single central vault concept ensures that, while data is immediately accessible to those who need it, all master documents and records of historical change remain absolutely accurate and secure.

- Better Control of Projects.

PDM systems enable you to retain control of the project by ensuring that the data on which it is based is firmly controlled. As well as this the change management, traceability and workflow capabilities, make scheduled tasks impossible to ignore, or to forget.

- Better Management of Engineering Change.

The system allows you to create and maintain multiple revisions and versions of any design in the database. This means that iterations on a design can be created without the worry that previous versions will be lost or accidentally erased.

- Total Quality Management Enhancer.

By introducing a coherent set of audited processes to the product development cycle, a PDM system should go a long way towards establishing an environment for ISO9000 compliance and total quality management (TQM). Many of the fundamental principles of TQM such as relying in individuals for identification and solution of problems, are inherent in the PDM structure.

### **Implementation of Product Data Management Systems**

Implementing a PDM system involves more than installing a software package. Even the most standard PDM packages, considered off the shelf solutions, require a level of customisation, of internal design and of adjustment to the organizational needs and structures. Because the PDM scope is to be an enterprise wide solution and to be integrated in the enterprise environment its implementation is more than a purchasing decision. This section will describe the general process of implementation of PDM systems first, and then will outline some specific issues, related to the subject of this thesis, i.e. implementing the system to support the reliability program [Man00].

#### **Analysing the needs and requirements**

The first step when implementing this type of systems is an in-depth analysis of the needs of the organization. This process has to identify and recognize problems, opportunities for

improvement and possible solutions. The current structure is assessed on practices and performance compared to potentials.

### **Selecting a PDM System**

Once the requirements for the possible improvements are outlined, the suitability of the PDM system has to be assessed. And once this is determined, then a PDM supplier needs to be selected. This can be a quite complicated choice. The functionality and capabilities of these systems are complex. The number of products offered is large and the market changes quickly. The size of the organization, and the level of expenditure assigned, will be relevant factors to consider.

### **Implementation of the system**

Once the solution has been selected, the real implementation process begins. For making full use of the benefits of the system, it is convenient to examine the current situation, and to try to re-engineer some of the processes within the company, that are sources of bottlenecks. The implementation of a PDM system is a great chance to introduce some changes in the engineering activities and operations. A deep understanding of the processes and products is needed to be able to implement and customize a PDM system. The key success of the implementation is a good cross-functional team, trained, and aware of the requirements and the capabilities of the system. It seems to be common practice, to implement first a prototype of the system. A selected subset of functionality is implemented in a particular part of the organisation. This process implies education and training, customisation of the package and structuring existing data.

### **Implementation of a PDM System for the reliability program**

In the case of the reliability program, the needs and requirements of the system have already been outlined, and PDM systems as suitable solutions have also been discussed. As to the issues of which PDM system to select, traditionally the business of PDM solutions had been divided into two distinct categories. High cost, feature heavy systems, versus low end, cheap systems, that were simply about document management. The high level solutions require long and expensive implementation processes, which often do not adapt to the dynamic business environment. They are also not suitable for mid-range or small size companies. The low-end systems, did not offer full capabilities, and they missed the integration and customisation tools that allow the company to make the most out of the system. The situation has changed considerably, and in recent years there has been a drift towards offering off the shelf solutions, that can be quickly implemented, and offer a configuration management capability, that allows the organization to customize the system to their needs. These mid-range systems have been looked at, as the most suitable type for

the reliability program implementation. An off-the-shelf package, that includes customisation and configuration tools, has been selected.

The process of customizing and implementing this software to serve the purposes of the reliability program will be described in the next chapters.

As discussed earlier one, the PDM system offers all the capabilities to serve as a good foundation for the reliability program. However, these systems are not specifically designed for reliability engineering, and the analytical capabilities are not supplied by the system. Therefore the customisation of the package will also look at the integration of reliability tools within the system, to cater for these requirements.

### **3.5 Summary**

An information system allows the organization to achieve efficiency and quality in most of its processes. The engineering activity is more and more concerned with having good information systems, to support concurrent engineering, and life cycle management. Since reliability engineering deals with every aspect of the product development, and requires information from every life cycle phase, it is necessary to have an information system that supports the reliability program.

After reviewing different types of tools that could serve the purpose of a reliability program plan, PDM systems have been selected as the solution that provides a better foundation for implementing the program and for further developing it. The fact that PDM systems manage the product information throughout its life cycle on an integrated and efficient manner is the summarized reason for their selection. The definition and concepts related to PDM systems have been covered, and the different components and features of these systems have been described.

Through the research carried out in chapter two, the different activities needed in the implementation of a reliability program plan have been identified. Implementing a PDM system to support the reliability program will have to provide data structures, procedures, methodologies and tools that support these activities. This process will be described in the next chapter.

# Chapter 4

## Case Study: Prototype of a Reliability and Field Data Management System (RFDM)

4.1 Introduction

4.2 Application Overview and Requirements

4.3 Overall Structure of the RFDM System

4.4 Design and Functional Specification of the RFDM Prototype

4.5 Summary

### 4.1. Introduction

The last two chapters have reviewed the analytical, functional and information requirements for planning, implementing and managing a reliability system within a company. Product data management systems have been selected as the most suitable information management tool for doing it.

This chapter will present the overall structure of a reliability management system based on the principles discussed. The author has developed and customized an application that operates reliability engineering in a specific company. Firstly, an overview of the company will be given. This will provide some general background information about the company and the specific requirements of their reliability engineering operation. Next the overall structure of the system will be outlined pointing out the different elements and how they interact within the system. Finally, detail specifications on the information structure, and the processes that need to be implemented to meet the requirements will be shown. The actual prototype developed based on these specifications will be presented in chapter five.

## **4.2 Company Overview and Requirements**

The company is a multinational organization that manufactures refrigeration units for transport. It is world leader in its business and committed to delivering quality products, with high performance, high efficiency, and low support and maintenance costs. As such, the reliability effort is the subject of continuous development and improvement. Because of the nature of their products and operations a few issues need to be considered for their reliability engineering strategies.

### **Company Environment**

Being a worldwide company with facilities in locations such as Europe, Asia or the States, it needs to guarantee that their operations are global and that communication and information sharing exists between different plants. Global teams and concurrent engineering across seas needs to be supported. The reliability engineering is no exception, and as such, reliability information needs to be shared across countries. As well as this, the reliability effort needs to be global and consistent across different engineering groups, with the common strategies procedures and methodologies.

### **Product**

Refrigeration units are multi-component products, based on mechanical engineering systems, e.g. compressors, engine, alternators, belt-drive systems, and also electronic parts in the form of sensors, transducers and a microprocessor that controls the operation of the unit. These units are subjected to a broad range of operating conditions, and extreme environments. The failure of the refrigeration unit can represent major financial losses for the owner.. For all of these reasons, reliability is a critical for a refrigeration unit performance. As well as reliability, maintainability is also important in supporting a product with a large time span. Since the application is transport, the unit travels all around the world, and maintenance effort needs to be assured and coordinated across many countries. It is also important to facilitate the possibility of diagnosing problems and repairing the unit in the field, to avoid major disturbances to the customer's operations.

### **Dealer Network**

The units are distributed through a dealer network, which has strong connections with the company. Dealers sell the units to the final customers and are generally in charge of maintenance and repair of the units. They are in fact the managers of the units during its operating life. The collaboration with dealers is very important, and it extends to engineering work, with dealers involved in product improvement, or new product development projects. Through their collaboration with dealers, the company has the

unique opportunity of accessing information on the product that would be generally lost in the hands of unknown customers. This information lies in very different areas, such as marketing and sales, quality and also reliability. Establishing appropriate communications paths, and collaborating with dealers is a major goal for the company.

Although the units and its components are heavily tested in-house, sometimes, as in many other applications, the only real testing scenario is the field. Information of the operation of the units, the types and modes of failure, and the environmental conditions and stresses, would be very valuable for the reliability engineering work. Providing the means for this information to be recorded in a meaningful format and accessible to the engineering personnel is one of the major purposes of the information system.

#### **Collaboration with Suppliers**

In manufacturing the company is mainly on assembly operation. There are very few parts and components produced in house, and most of them are bought from a large range of suppliers. Issues of reliability with components in the unit need to be addressed in collaborative programs with the suppliers of these products. The suppliers and their knowledge of the components and the company with their expertise in the application need to have an information exchange policy that should be facilitated by the system.

### **4.3 Overall Structure of the RFDM System**

The general structure of the RFDM software based system developed is shown in figure 4.1. The system has been developed to meet the requirements for reliability management in the context of the companies operations. The elements of the system are outlined next.

#### **Information Structure and Interface**

The core of the system will consist of the information structure and the managed databases. This information structure is built through the customization of the PDM system to the specific requirements of the reliability management program. The managed data will take the form of databases, which can have different locations and distribution. Meta-data refers to the data structure of the PDM system, i.e. attributes, fields, indexes or types. The PDM system will also provide security and access control, and additional features like revision control, consistency, data validation, and a convenient interface for the users to access this data. The interface of the system has the purpose of allowing the users to access the information in an efficient way, allowing them to retrieve the information that they want easily and quickly, and providing a user-friendly environment that can be customized to suit each users particular needs.

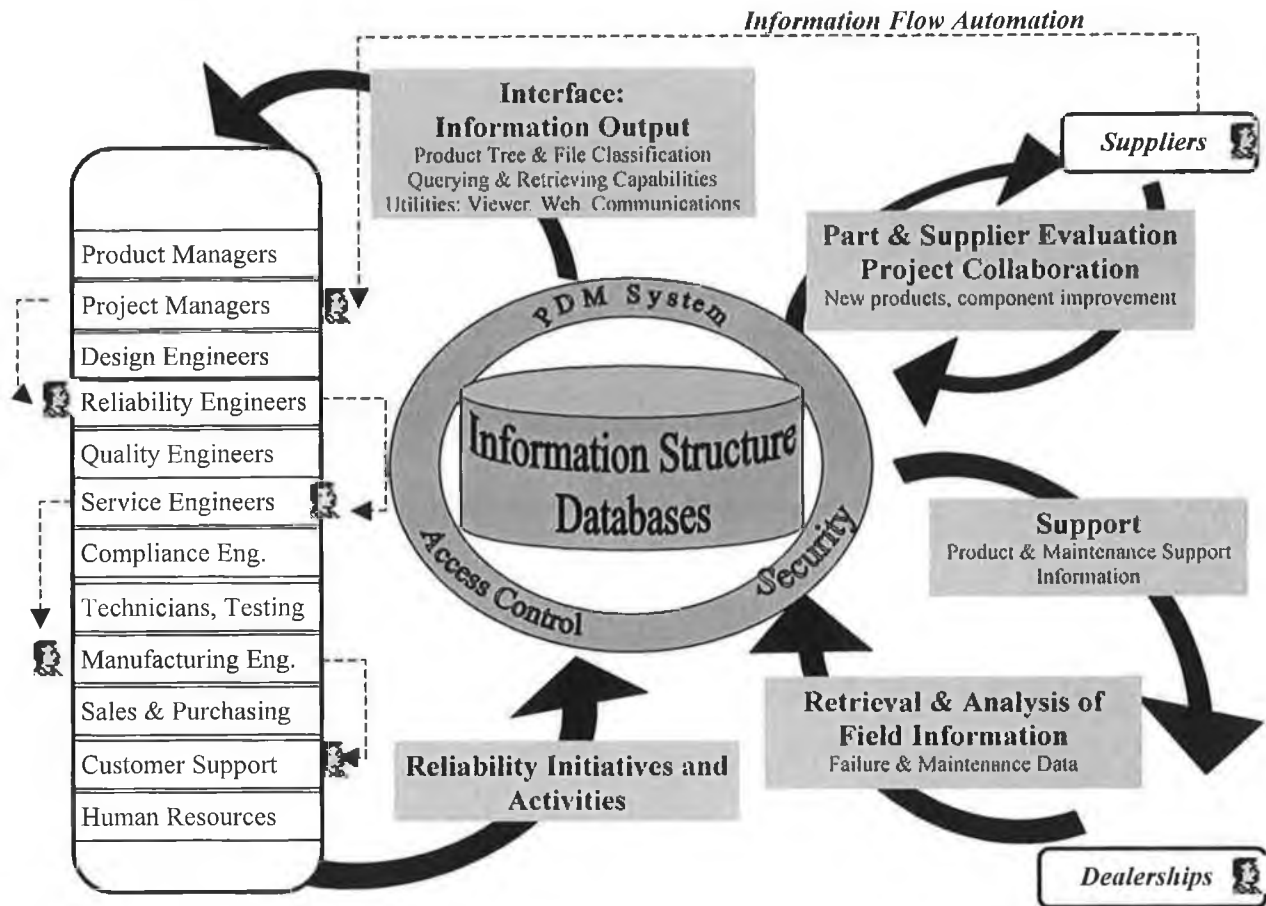

Figure 4.1 Reliability Management System: Overall Structure.

The PDM system provides output through tree structures, querying/retrieval capabilities, and utilities such as multi-language, data translation, or viewing options. Personnel from different areas, teams and locations will be able to access the data through this interface, given that they have access control. The system will be web-enabled so that users can have access to it if working away from their usual workplace.

#### Information Input. Reliability Processes

As well as giving users optimal access to information, the system has to support the analysis of information through different processes, and has to guarantee that the outputs from these analyses are fed-back into the system in an appropriate format. Therefore the system integrates procedures, guidelines, checklists and software tools that support reliability initiatives. The outputs of these processes, in the form of reports, data, or lists, must have defined locations in the system.

For the specific application that is being used as prototype example, the initiatives that have been selected are as follows;

1. Field Data Reliability and Costing Analysis
2. Failure Report and Corrective Action System
3. Critical Item Reliability
4. Parts and Supplier Evaluation
5. Reliability Prediction Methods
6. Failure Mode Effects Analysis (FMEA)

### **Field Information Management**

One of the most valuable sources of information for reliability work is very often the least accessible to engineers or organizations, i.e. information on products in their operational life. Accessing this support phase information has many different implications. It allows engineers to fully understand the issues concerning the life of the product, its performance and failure. It also provides valuable knowledge on economical aspects such as operational or maintenance costs. In a market situation where purchasing price is starting to be overlooked in favor of cost of ownership, and specially in applications with heavy maintenance demands, access to support information is critical to improve products, and to maintain sales. As well as this, the organization need to be more open with their customers, sharing with them information on products, components or engineering activity, and effectively converting the customer in an element of the organizational structure.

All of these can be achieved by information management and sharing. Because of all of the above, special attention is given in the RFDM system to the information exchange and feedback from the dealer network. A sub-system designed to retrieve and analyze this information needs to be designed, and its structure is outlined in figure 4.2. The requirements of this system are outlined next.

#### **1. Data Synthesis Tool**

In order to be able to retrieve and analyze the information a standard format needs to be agreed and implemented. Ideally the organization would supply dealers with a software tool that would store all the information in the appropriate format. As well as providing consistency, the tool would assist and facilitate the process of entering information, and could also be designed as to support dealers in internal management of their products and workshops. Specifications and descriptions on this tool can be found in reference [Her00].



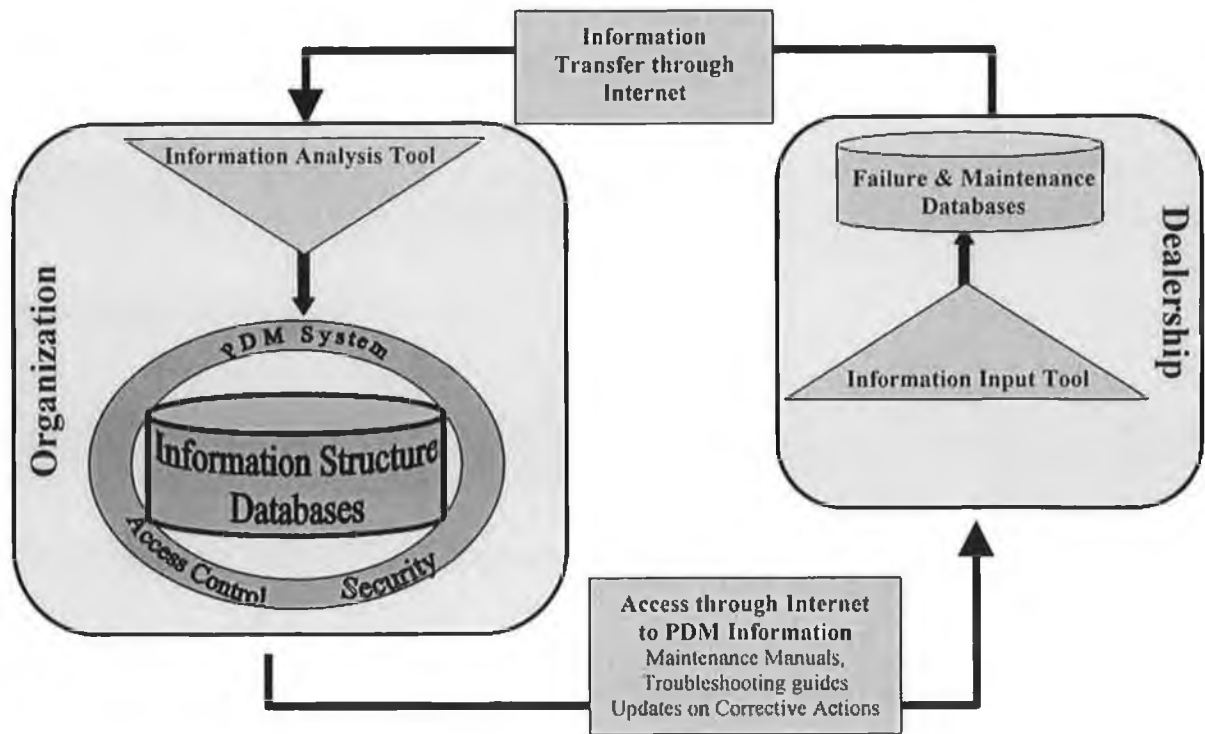

Figure 4.2 Support Information Management Structure.

## 2. Data Communication Tool

Because of physical location requirements, the structure should be able to connect organization and dealers through an internet connection. This would allow for the input of information to be possible at any time, from any given place (provided there is an internet connection), and it would also facilitate the retrieval of relevant information from a remote location. Specifications and description on this tool can be found in reference [Her00].

## 3. Evaluation and Storage

Information on failure and maintenance of products can represent a huge amount of data. All of these data cannot be stored permanently in the organization. Data needs to be transferred from dealer's sites into the organization at given intervals, then be analyzed with the aid of developed software, and finally be stored for a certain amount of time, and then deleted. The results of the analysis can be stored for further reference in the form of documents in the PDM system.

To support the product efficiently the organization needs to share with the dealer network information such as maintenance manuals, repair instructions or troubleshooting guides. The support information needs to be available on a reliable, fast and efficient manner. The

information shared with dealers needs to be up to date, and renewed as engineering work progresses. Since the PDM system is the location of all the progress of the engineering work, opening part of the information in the PDM to dealers seems to achieve this consistently. The PDM also provides great flexibility, because access levels can be controlled dynamically by the administrator to different people at different stages. In order to have full collaboration, dealers have to be given a way of feeding back information into the system, such as comments on certain documents, suggestions or complaints. This is also supported through the PDM system provided that it has read/write capabilities.

#### **Automation of Information Flow**

Some processes that are carried out in the context of reliability engineering involve documents and information being brought through a predetermined and standard workflow path, where different users perform different tasks sequentially. These processes are usually carried out periodically. Automating these processes through the workflow utility of the PDM system, means that information is passed on automatically and efficiently in pre-designed flow processes, and that full control over the processes is possible. This part of the RFDM system is referred to as information flow automation.

### **4.4 Design and Functional Specification of the RFDM System**

In order to implement the RFDM prototype system, based on the requirements outlined above, three different levels of the structure need to be specified as follows;

- Level 0: Information structure
- Level 1: Structure of reliability processes
- Level 2: Workflow automation structure

#### **Level 0 Information Structure**

The information structure needs to integrate all the information and data that will be used in the different processes. It also has to be designed so that it can store the results of these processes in a convenient format. The information structure will be implemented through the customisation of the PDM system and will serve as the base for the operations of the system. The layout of the structure that has been developed is shown in figure 4.3. This data structure is designed into an Interbase database. The structure consists of a number of classes that are conceptually linked as shown. However, logical links between any two objects can be established, as it will be described further on. In this way, information in the system becomes a network, where any relation between objects can be supported.

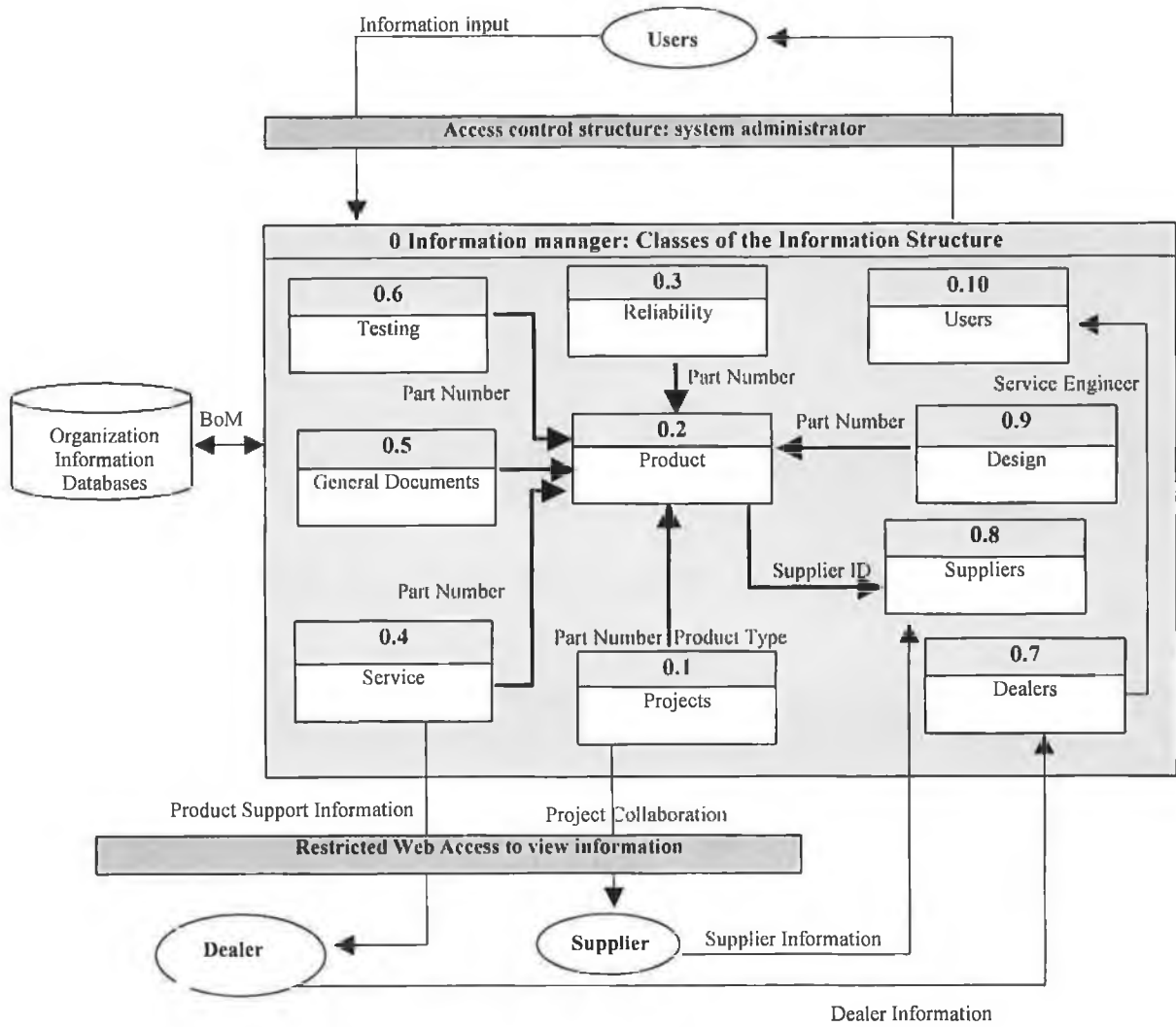

Figure 4.3 Level 0: Information Structure.

Further descriptions and details on the information structure and the user interface are given in chapter five.

### Level 1 Reliability Processes Structure

A number of reliability initiatives and processes have been selected based on the requirements of the application. Some of these initiatives are carried out through the use of software tools, and some others are implemented within the functionality of the PDM System. Figure 4.4 shows the overall structure of these processes. Each process will be then specified in detail.

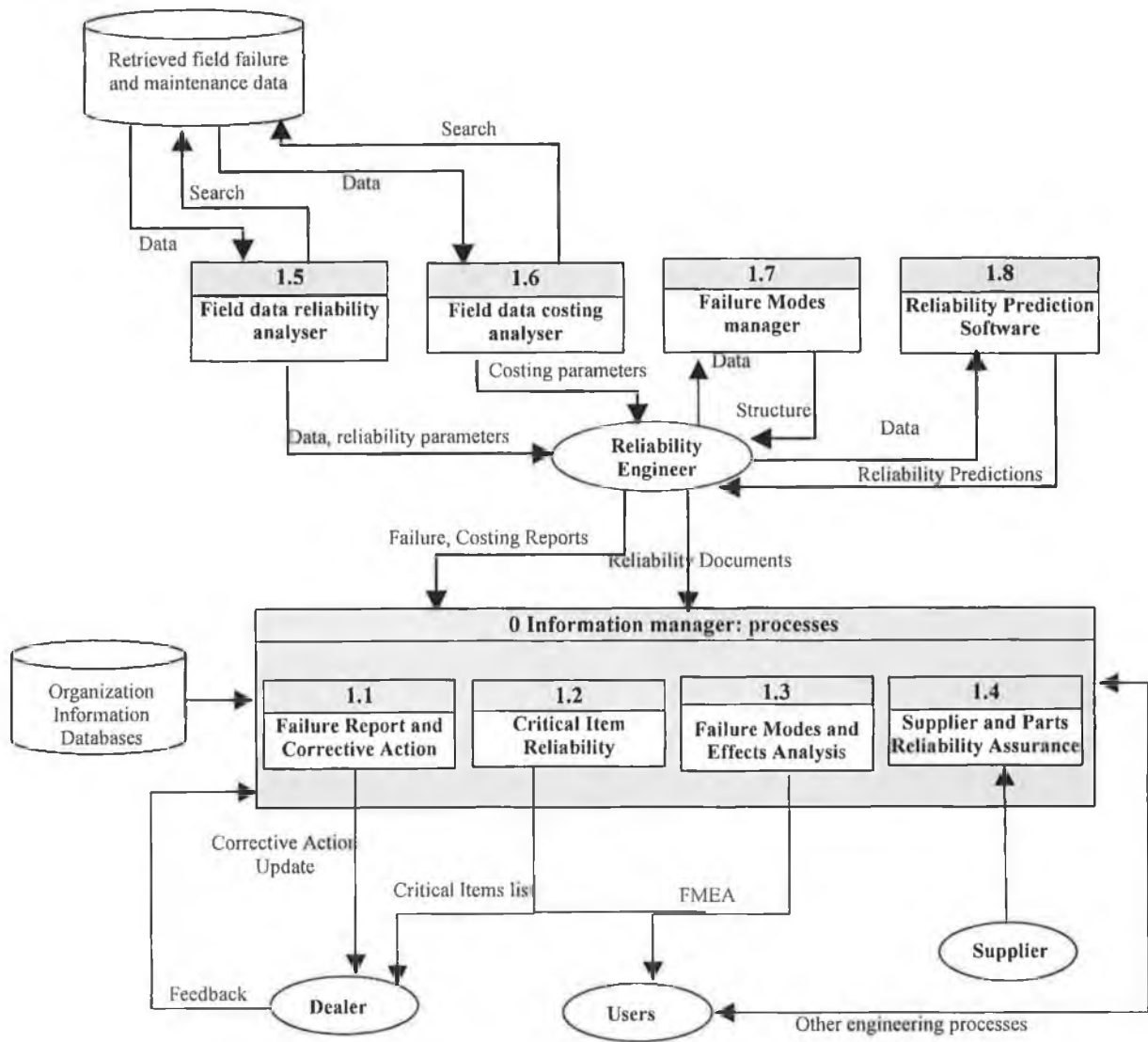

Figure 4.4 Level1. Reliability Processes.

### Process 1.1 Failure Report and Corrective Action System

The Failure Report and Corrective Action System has the purpose of supporting the identification of product failures, the development of corrective actions, and the implementation of these actions. This process is carried out within the information manager, or PDM, by using some of its functionality and data structures. The system structure is shown in figure 4.5.

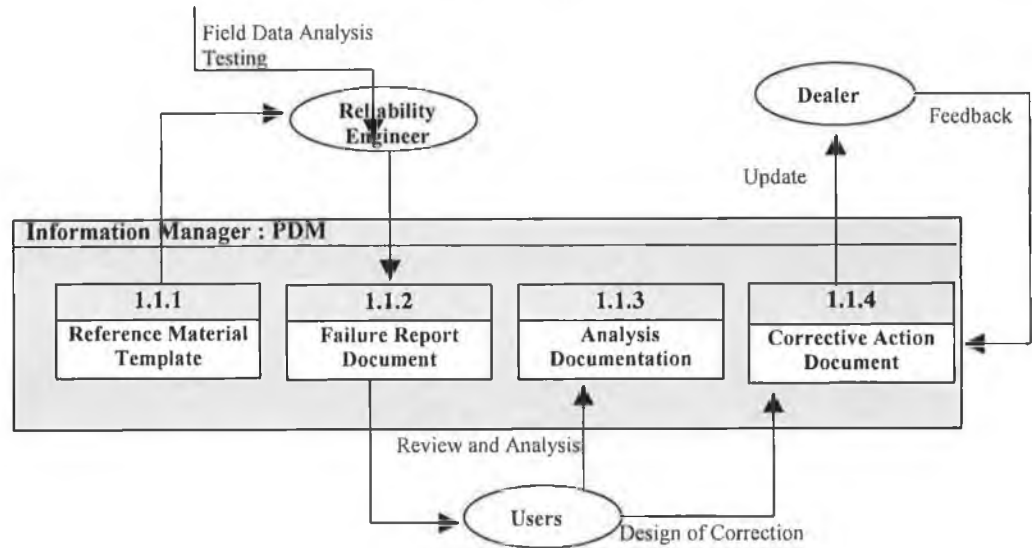

Figure 4.5 Process 1.1 Failure Report and Corrective Action System.

### Process 1.2 Critical Item Reliability

A critical item is a component whose failure can significantly affect reliability, safety or repair/replacement costs. Process 1.2, Critical Reliability supports the engineers in managing critical items, by providing the means for identifying critical items, ranking them, and by giving access to the list of critical items at any moment to both dealers and users. This information can be used in many ways, e.g. by intensifying maintenance, considering re-designs or implementing component improvement projects. The structure of this process is shown in figure 4.6

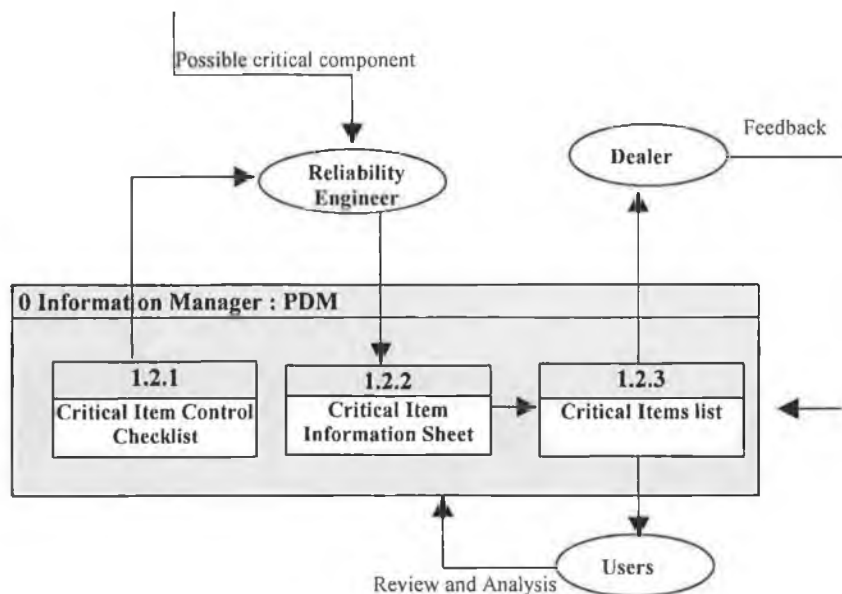

Figure 4.6 Process 1.2 Critical Item Reliability.

**Process 1.3 Failure Modes and Effects Analysis and 1.7 Failure Modes Analyzer**

Failure Mode and Effect Analysis is a methodology extendedly used in design for reliability. The system provides a template for the analysis, and a class that stores FMEA documents, so that users can access them. Making this information available is very beneficial since FMEA analysis can be relevant in issues as follows;

- Highlight areas needing corrective action.
- Identification of reliability and safety critical components.
- Visibility of system interface features and problems.
- A basis for location of performance monitoring and fault sensing test equipment or test points.
- Areas where fail-safe or fail-soft features are needed.

The results of the FMEA analysis are used by the reliability engineer to enter the relevant information on the Failure Modes Analyzer. This module can be used to feed this information back to the dealer in order to support maintenance operations. It can also be used to guide the dealer in identifying failure modes, in order to get more accurate information on the failures of parts and its causes.

The basic structure of the process is shown in figure 4.7

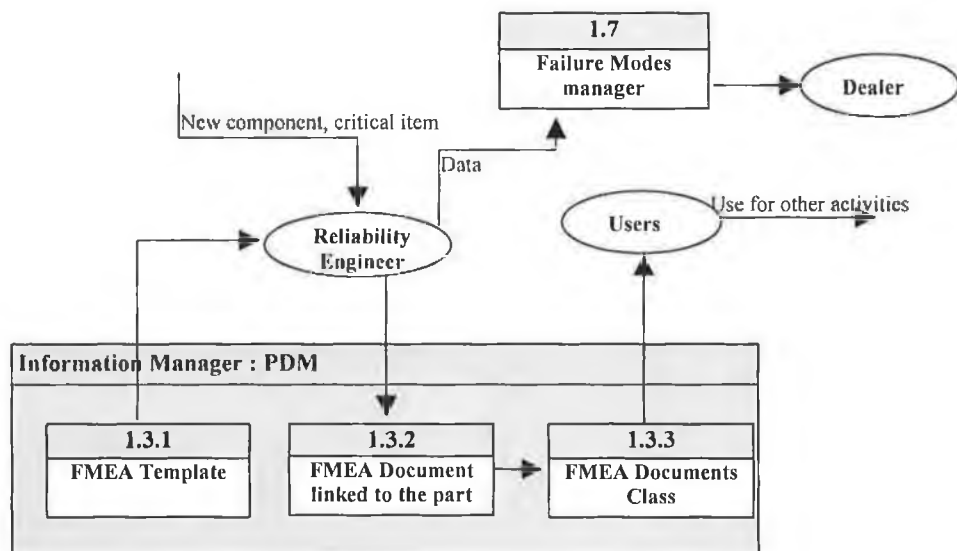

Figure 4.7 Process 1.3 FMEA documentation.

**Process 1.4 Suppliers and Parts Reliability Assurance**

The Suppliers and Parts Reliability Assurance process is designed to assure that suppliers and parts are systematically assessed, and that the outputs of the assessment are stored for further analysis and review.

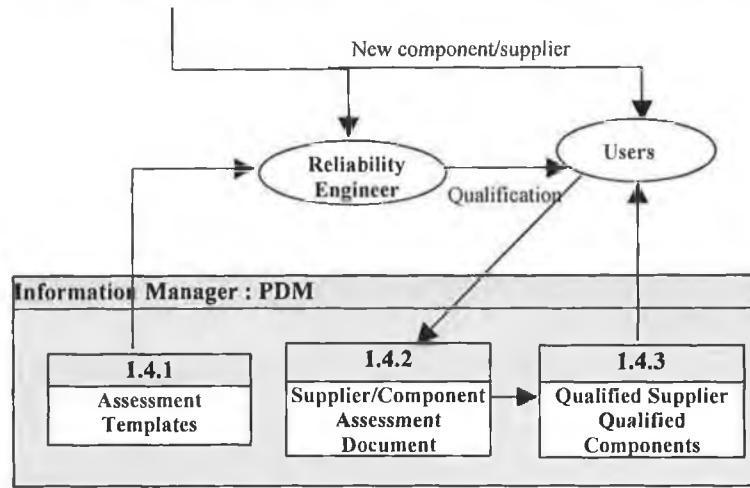

Figure 4.8 Process 1.4 Suppliers and Parts Reliability Assurance.

### Process 1.5 Field Data Reliability Analysis

The Field Data Reliability Analyser takes the form of a developed software tool, that has the purpose of searching the failure database based on a given criteria, retrieving the data, and performing some standard calculations that give an idea of reliability parameters in the data. Summaries of this analysis and produces, and are then stored in the information manager. Figure 4.9 shows the layout of this process.

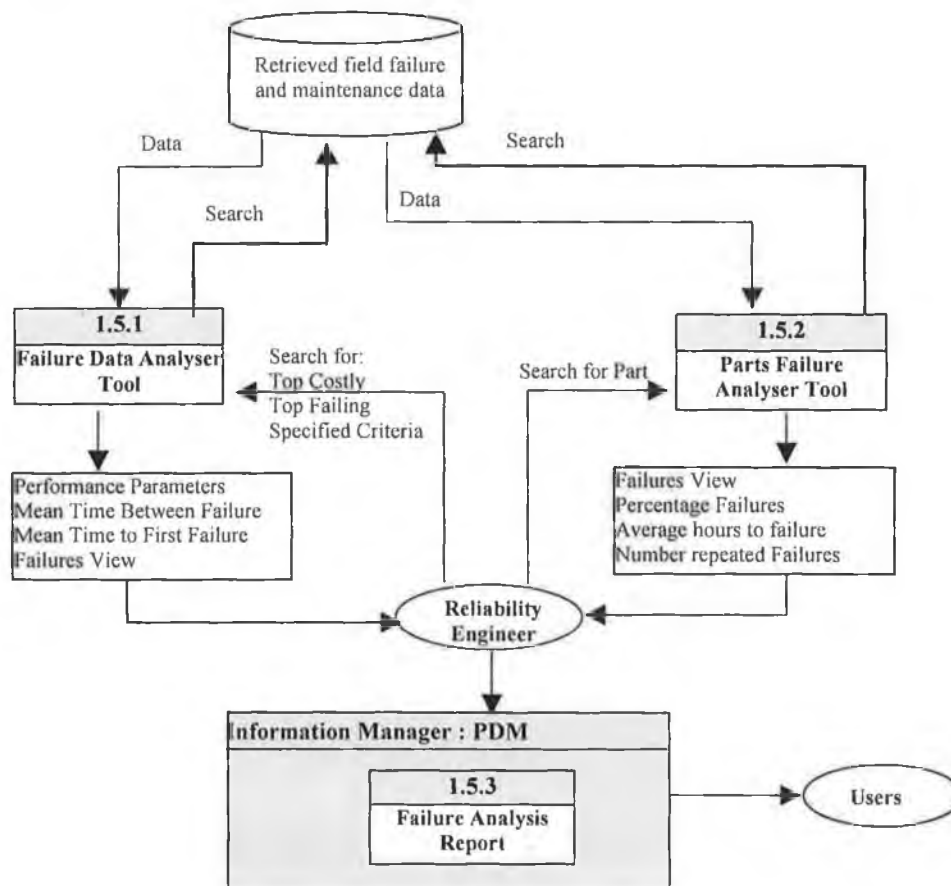

Figure 4.9 Process 1.5 Field Data Reliability Analyser.

### Process 1.6 Field Data Costing Analysis

Field data can also be used to calculate costing parameters of the operational phase of the product. This can be valuable information in calculating life cycle costs, and in planning maintenance and support strategies. Figure 4.10 shows the process of doing Field Data Costing Analysis.

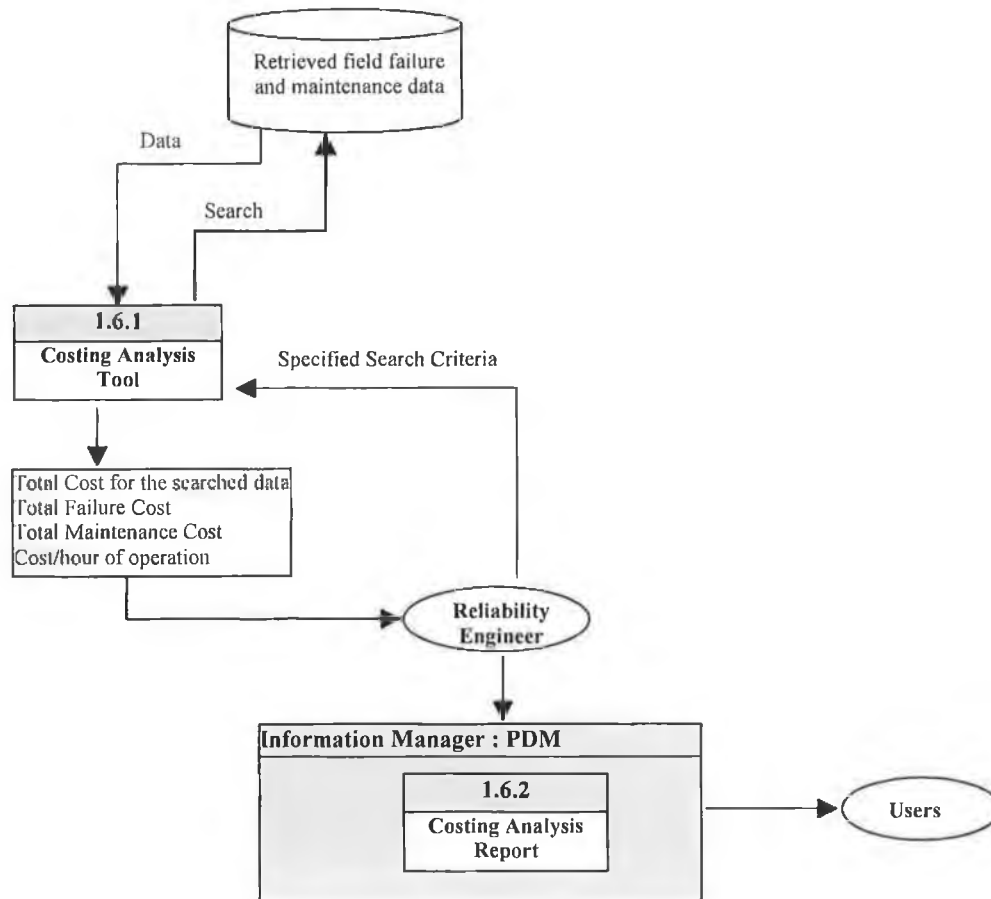

Figure 4.10 Process 1.6 Costing Analysis.

### Process 1.7 Reliability Predictions

Reliability predictions can be based on a number of different sources, as listed below;

- System Reliability Assessment. Combine predictions, process grading, operational profiles, software and test data to predict reliability parameters.
- Similar Item Data. Based on empirical reliability field failure rate data on similar products operating in similar environments.
- Translation. Translate a reliability prediction based on an empirical model to an estimated field reliability value
- Empirical. Uses observed failure data to quantify part-level empirical model variables.
- Physics of Failure. Models each failure mechanism for each component individually.



In most of the cases, different software tools are used for calculating reliability parameters. There is a range of different option, e.g. reliability block diagram engines, or lifetime analysis distribution packages. In any case it is the job of the reliability engineer to prepare and treat the data, in order to get good results. When making predictions based on field data, the Failure Analyser tool can be of great value in this process. Documenting reliability predictions is very important for reliability assessment and reliability growth tracking. The process of reliability predictions is described in figure 4.11.

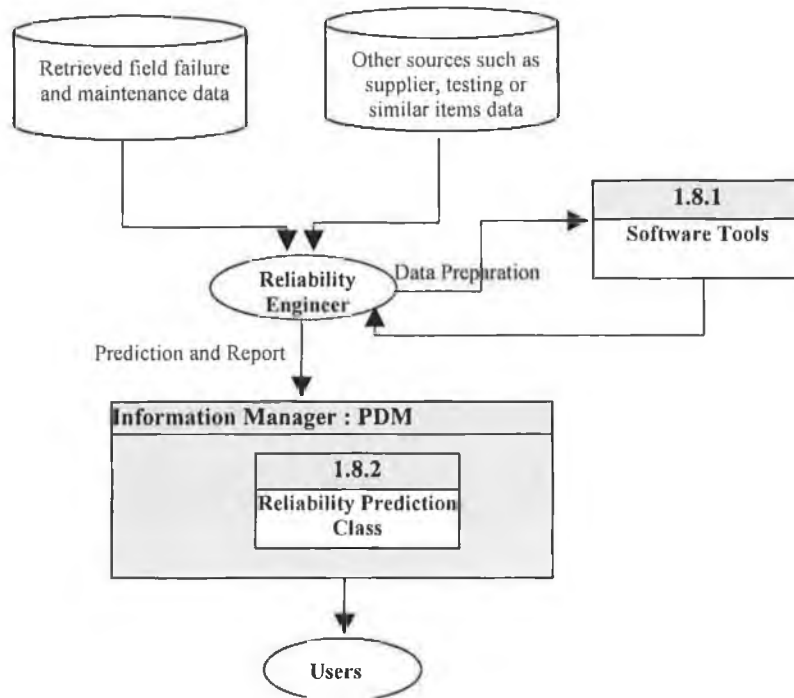

Figure 4.11 Process 1.10 Reliability Predictions.

### Level 2: Workflow Automation Structure

This layer of the structure shows the workflow paths have been designed to optimise the operation of the system, and to carry out some of the reliability initiatives. These workflow processes will be automated through the PDM system, so that information and documents will be brought through the designed paths automatically by the system. Figure 4.12 shows the overall layout of the workflow paths structure. Four flow processes have been designed. Users of the system, reliability engineers, dealer and suppliers interact throughout these processes. At each step of the process, a number of participating users are defined together with the tasks that have to be performed. The tasks will be normally automatically distributed to the users as indicated in the flow process.

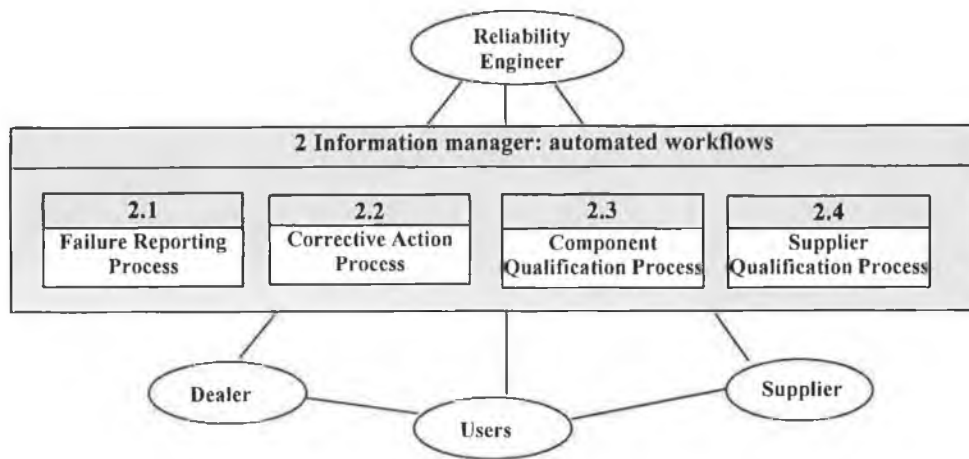

Figure 4.12 Level 2 Workflow structure.

Because failure feedback is a major issue to be considered, failure reporting needs to involve different users of the system. The purpose of this process is to inform of approved failure report documents to the relevant users, and gather the views and suggestions of these users for further reviews. Failure reports are therefore automatically distributed throughout the process. Users receive notification through their workflow mailbox. The failure reporting process is illustrated in figure 4.13. Each box represents a stage in the process. The users and tasks to perform at each stage are indicated in the diagram.

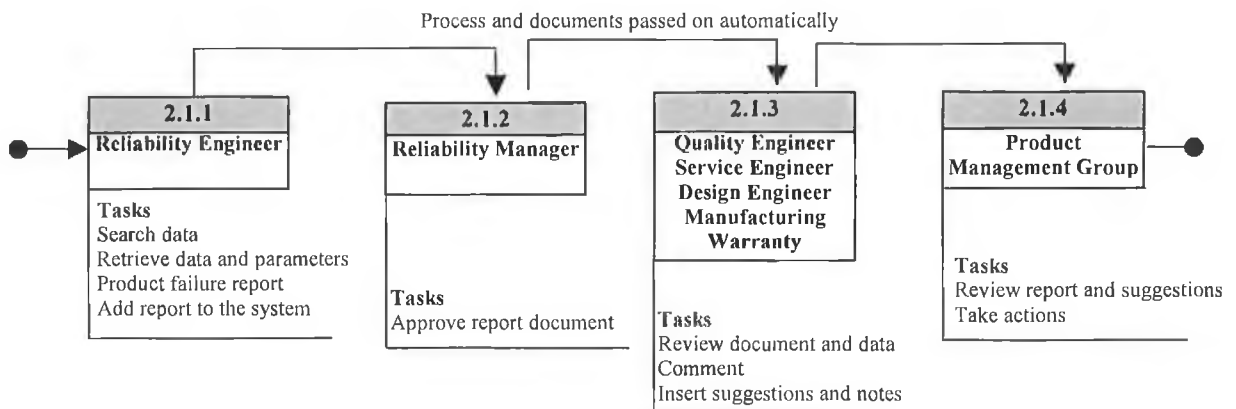

Figure 4.13 Workflow 2.1 Failure Reporting Process.

After reviewing failure reports, or customer’s feedback, corrective actions might be considered. In the process of design, many users are usually involved in reviewing and assessing the progress. However, when implementing corrective actions this interaction is not always the case, and sometimes actions might be implemented without the relevant

users review and assessment. The corrective action process has the purpose of bringing the suggested corrective action throughout the relevant users, to assess and approve the action. Also through the process logistics is organized, e.g. documentation, instructions, spare parts and kits. Figure 4.14 shows the workflow process for corrective action implementation, the users involved and the tasks that are performed by these users.

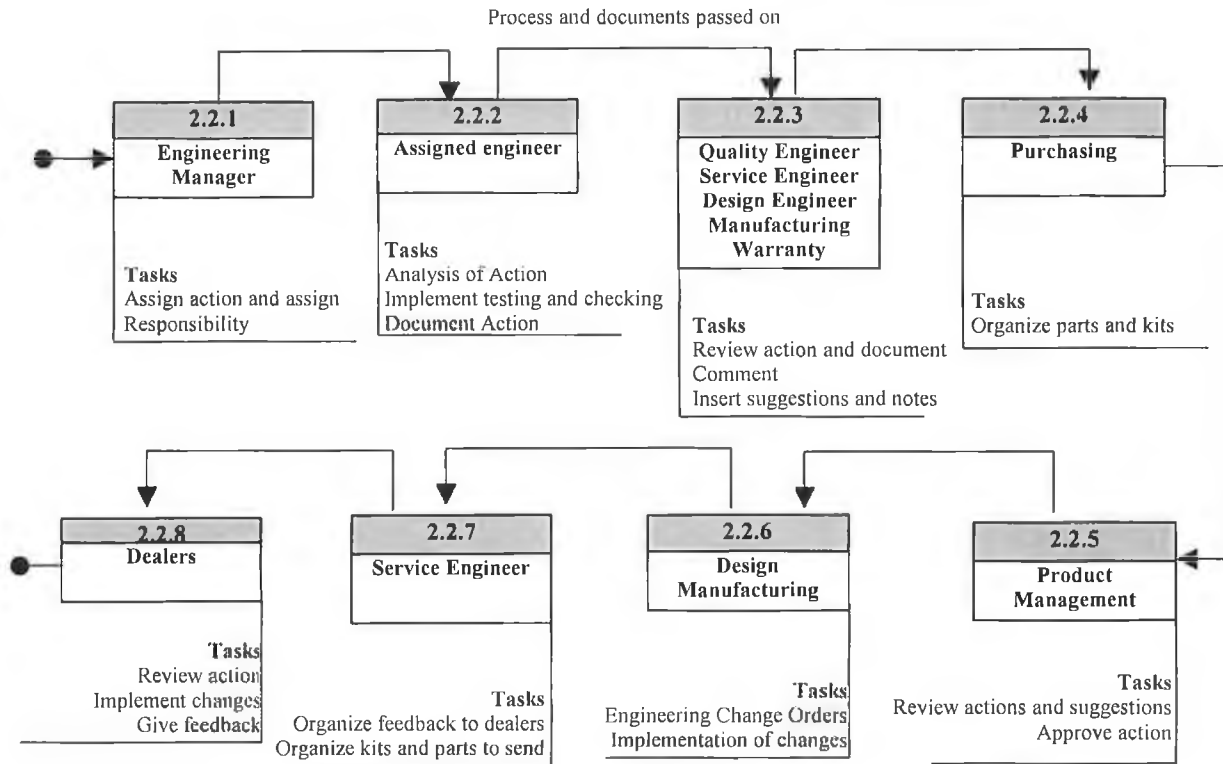

Figure 4.14 Workflow 2.2 Corrective Action Implementation.

Another case of information needing to pass through different users for review and interaction is the qualification of suppliers and parts. When a component or a supplier is to be qualified, different issues and perspectives need to be brought into consideration, i.e. logistics, reliability, quality or design specifications. In order to assure that all the specified users participate in these processes, a workflow has been designed. The process of supplier qualification, for supplier reliability assurance is shown in figure 4.15. This process also assures that documentation on the assessed aspects is produced and stored for further reference.

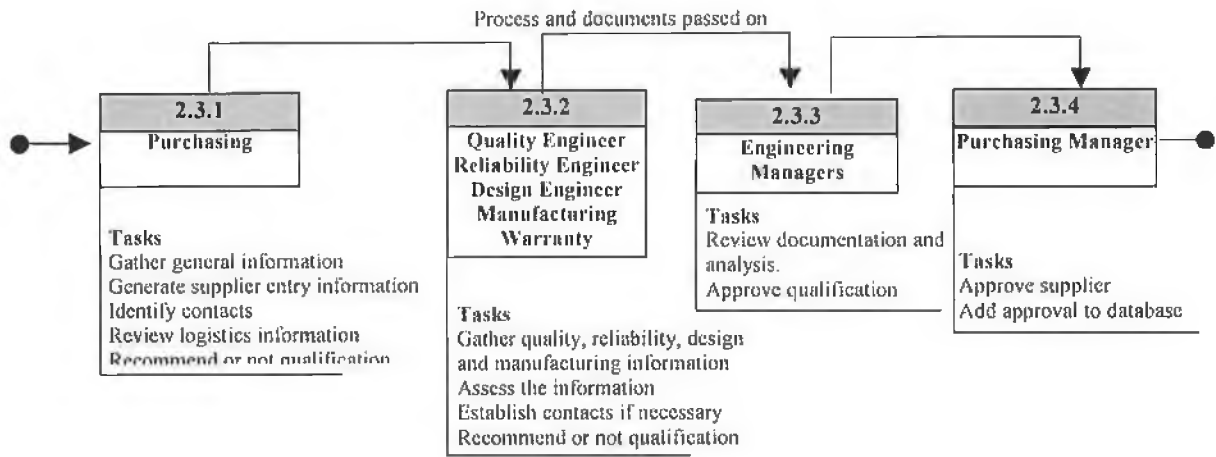

Figure 4.15 Workflow 2.3 Supplier qualification process.

The process of component qualification, implemented to assure reliability assessment of every component is illustrated in figure 4.16.

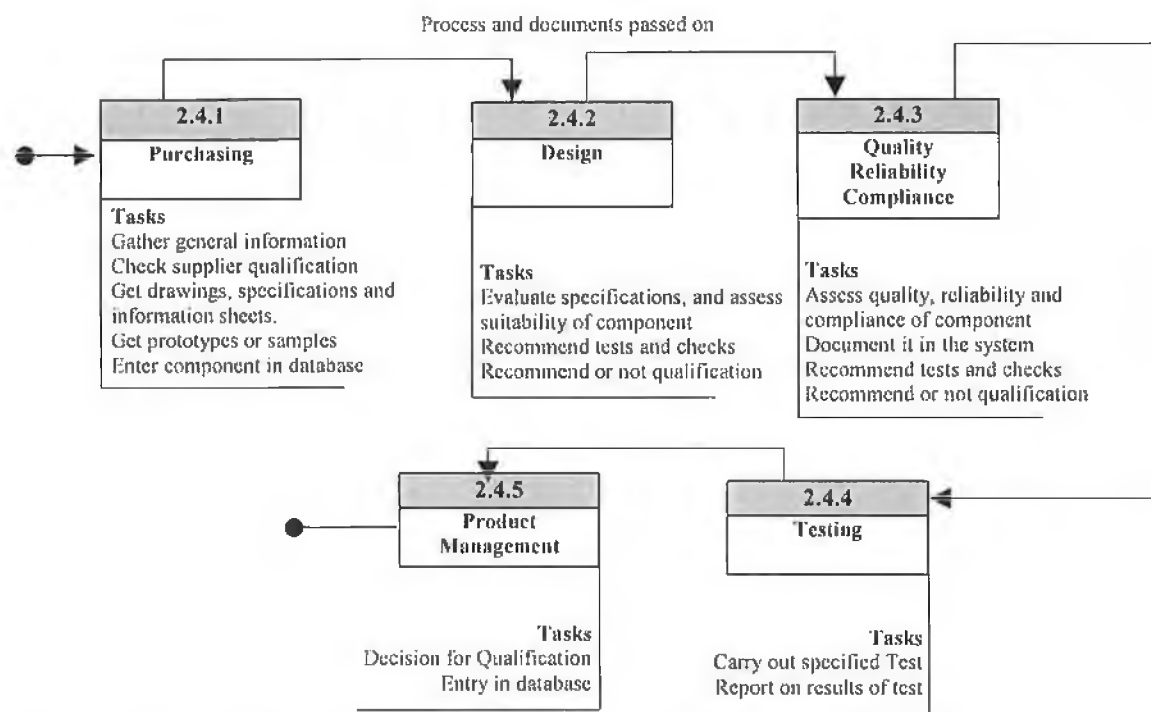

Figure 4.16 Workflow 2.4 Component qualification process.

Other processes that can be implemented through workflow paths include, engineering change orders implementations, engineering project requests, or engineering testing requests. Because they are not specifically designed for reliability management, they won't be specified.

## **4.5 Summary**

The implementation of a reliability management system based on PDM solution is going to be tested by prototyping a reliability management system for a specific company. The customization requirements have been reviewed and the general structure of the system has been outlined in this chapter. The relevance of support phase information management has been pointed out, and it will therefore receive specific attention when developing the system.

The different processes and structures that the system must integrate have also been specified, by dividing the system implementation in three different levels: information structure, reliability processes and workflow automation. The information structure specified will be implemented by customizing the PDM information structure and interface. This will guarantee that all the data and information that needs to be managed has its location in the system, and that users profit from these information through the PDM utilities, e.g. viewer, searching, querying or multi-language.

Some of the reliability processes will be carried out within the system functionality, and some others will need from the support of software tools. Either way, the outcomes or results from the processes will be feedback into the PDM for knowledge building, and future reference.

Finally, some of the processes can be optimized by carrying them out through automated workflow paths that bring information and documents along specified paths of users, where tasks are performed sequentially. The workflow paths that will be used have been specified.

Chapter five will outline the operation of the prototyped RFDM system, that has been developed based on the specifications reviewed.

# Chapter 5

## Prototyped Reliability and Field Data Management System (RFDM)

5.1 Introduction

5.2 RFDM Overview

5.3 Performing Field Data Reliability Analysis

5.4 Failure Report and Corrective Action System

5.5 Critical Item Reliability

5.6 FMEA Analysis

5.7 Suppliers and Parts Qualification Processes

5.8 Reliability Predictions, Specifications and Requirements

5.9 Summary

### 5.1. Introduction

In chapter two the principles of reliability engineering have been outlined. The requirements to manage reliability activity and reliability information have been outlined in chapter three, and Product Data Management has been selected as the framework to develop the reliability management system. In order to build a prototype of the system, a case study has been presented and its requirements have been outlined in chapter four.

This chapter will cover the design and implementation of the reliability management system based on the principles discussed, and customized to a specific application. First the customisation of the PDM system will be shown, describing the information structures developed and its user interface. Various types of structures and tools for supporting the reliability activity will be also described and integrated in the system. Information flows will be automated through workflow paths. The operation of the system will be shown with examples of a number of reliability initiatives.

## 5.2 RFDM Overview

The RFDM front screen intends to be the working environment for a reliability engineer. From this screen, the user can operate the different tools that have been selected for carrying out reliability activities and processes. The front screen of the RFDM system is shown in figure 5.1

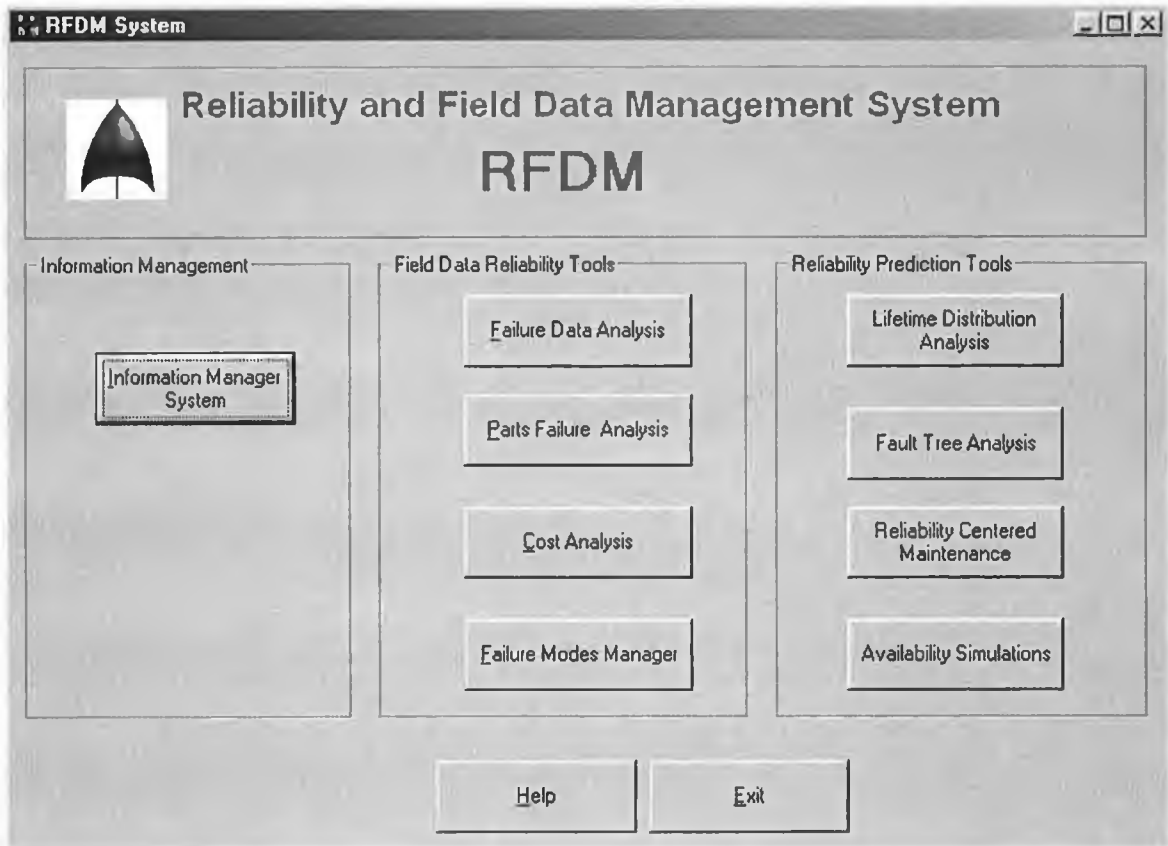

Figure 5.1 RFDM Front Screen.

By using the different buttons, the user can launch different tools and applications as follows:

**PDM system.** Launches the information manager system. This system stores all the documentation and reference data. Some of the reliability processes will be carried out within this system.

**Failure Data Analysis.** Launches the software developed to search the failure database and perform calculations on reliability parameters.

**Part Failure Analysis.** Launches the software developed to perform reliability calculations on failure of parts and components.

**Cost Analysis.** Launches the software developed to perform cost analysis on field data.

**Failure Modes Manager.** Launches the application that manages the identified failure modes, and that can be used for feedback and reference

**Reliability Prediction Tools.** The buttons on this category launch the different software packages that are available for the reliability engineer to perform different types of reliability simulation and prediction analysis. As an example, four packages have been integrated, i.e. *Weibull5*, that performs lifetime distribution analysis on data, *Ftp*, a package designed for fault tree analysis, *RCM*, that is intended for reliability centered maintenance and finally *AVSim*, a availability simulator. The system can be designed as to accommodate the specific tools that are available for the organization. The operation and description of each specific tool will not be described.

### 5.2.1 Information Manager: PDM System

When launching the PDM application, the user is requested to login into the system as shown in figure 5.2. Different users have different access to information and different working environments.

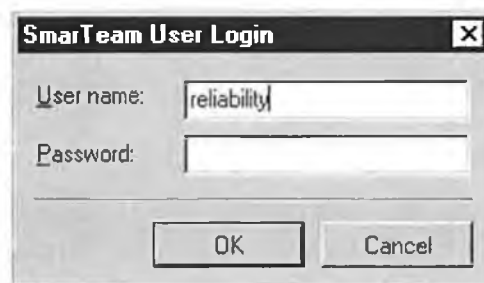

Figure 5.2 User login to the Information Manager.

The interface of the PDM system presents the user with tree structure views of each class that can be selected by buttons located on a toolbar. Figure 5.3 shows this buttons.



Figure 5.3 Class Buttons Toolbar.

When a class is selected a tree structure of all the objects belonging to that class is shown. From this tree structure, the user can select specific objects, and view all the information pages designed for that object.

These information pages will generally consist of the following elements:

- Profile Card. All the relevant information on each object is summarized on the profile card.



- Links. An object in the system can be logically linked to any other object, by bringing it to the links page. The links page allows to view all the links of the object, and access them if necessary.
- Notes. Users can add notes or comments to the object through this page,
- Viewer. When the document represents a file, the viewer page allows the user to view the file without editing it.

The interface also includes querying buttons that allow the user to search for information based on multiple criteria. These queries can be saved and built into views that are accessed through the viewing shortcut buttons. When the view button is searched, the specified search is automatically performed.

The interface of the information manager is shown in figure 5.4.

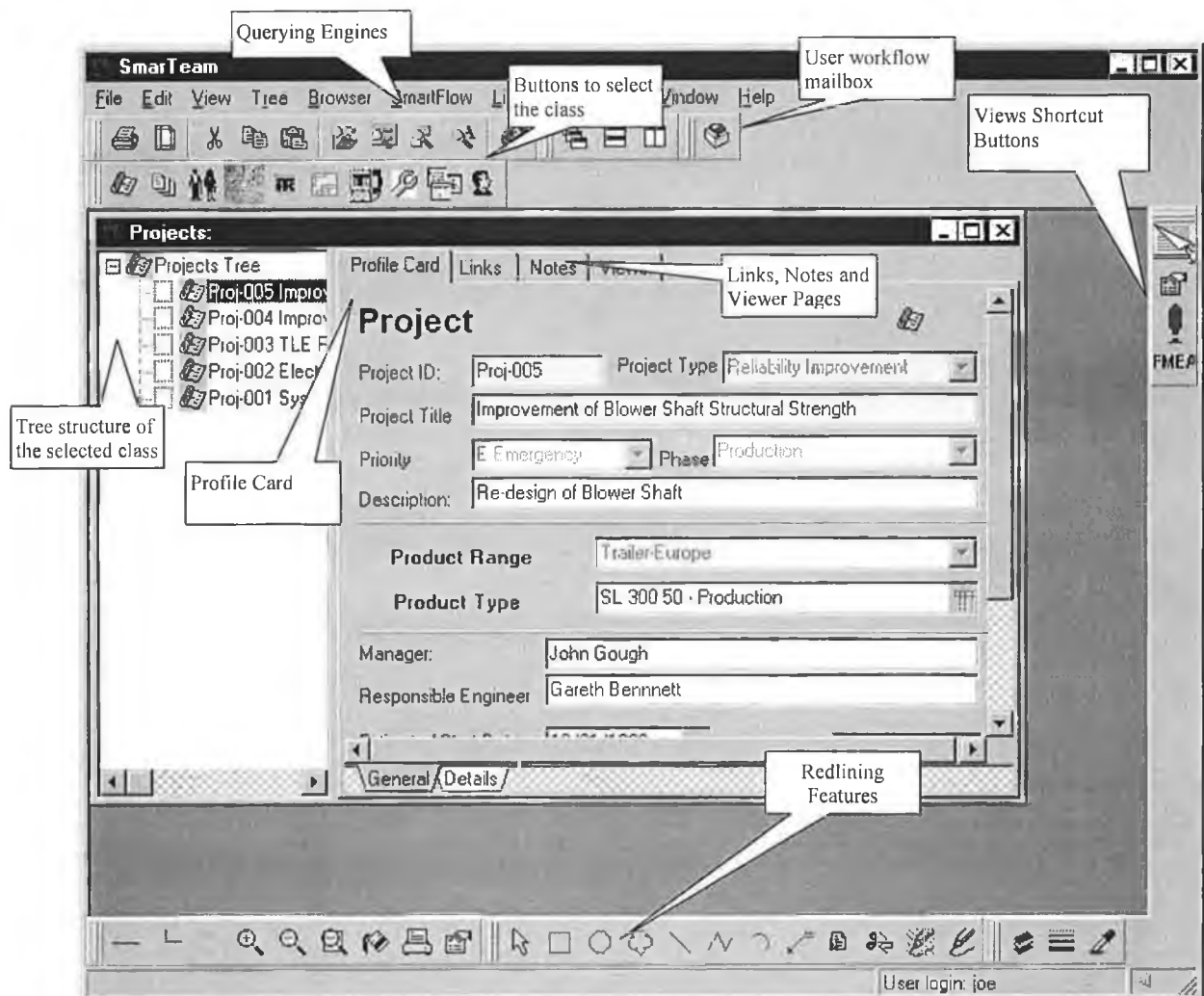

Figure 5.4 User Interface of the Information Manager.

The redlining functions allow the user to redline all documents, without editing them. It allows users to point out issues, and give feedback in the cases where they have no access to change the document, or have no software to edit it.

The user can also access his/her mailbox in the workflow automation system, through this interface, by pressing the smartbox button. In this mailbox, the user can view all the processes in which he/she is involved, the information on the processes, the tasks that he/she needs to perform and the time limit allocated. He/she can also access the status of the processes where he/she has participated. The interface of this mailbox system is shown in figure 5.5.

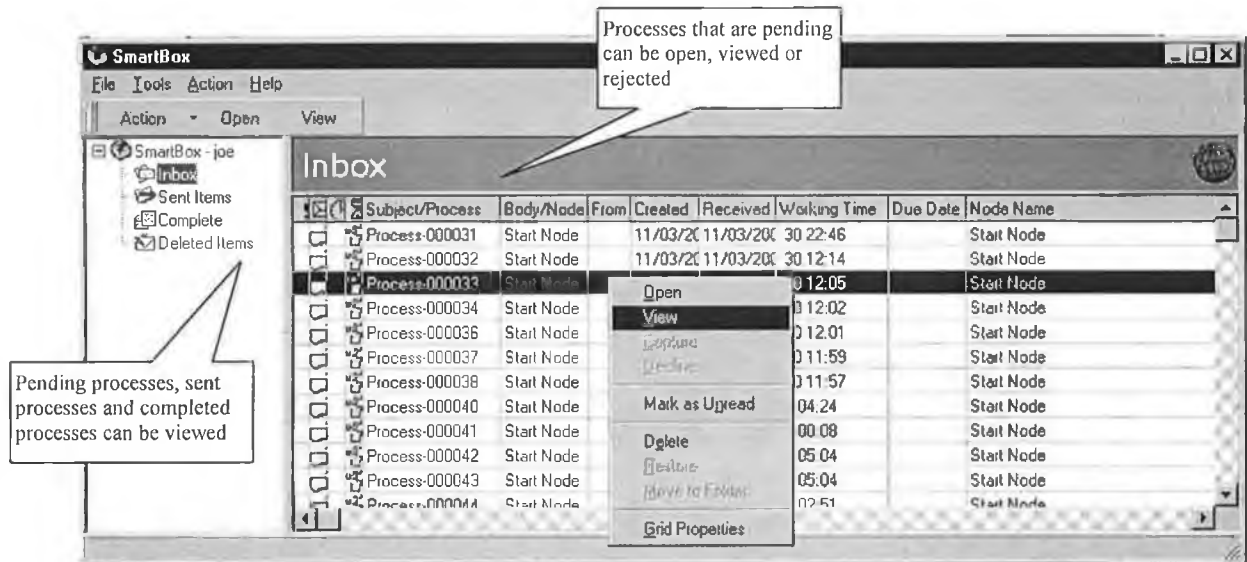

Figure 5.5 User workflow mailbox.

The information structure, as specified in chapter four, consists of ten classes, i.e. projects, suppliers, dealers, users, products, reliability, testing, service, design and general documents. Each of these classes has a number of subclasses. The pages of information defined for each class and subclass can be customized to display specific fields of information<sup>5</sup>. Some of the characteristics of the classes are as follows;

- **File control.** A class having file control stores objects that are actual files in the system. Certain attributes such as file type, file directory or application path are automatically added to the class descriptive attributes. Operations such as viewing and editing within the system are operative in file-controlled classes.
- **Revision control.** When a class has revision control, life cycle management of the objects is possible. Objects and documents can be released, registered, checked in and checked out. Once documents are registered, automatic versioning is generated when a document is changed.

Table 5.1 summarizes the different classes and subclasses, their icons, description and major characteristics.

<sup>5</sup> A sample of pages of information that have been designed in the system is given in appendix 5.











Hierarchy	Data Structure									
	Projects 	Suppliers 	Products 	Dealers 	Test 	Design 	Reliability 	Service 	Documents 	Users 
<b>Description</b> <i>(Roots of tree structure)</i>	Captures information on engineering activity.	Stores standard information on suppliers, their qualification, quality and reliability.	Manages the information on the product, through a Bill of Material Structure, and focusing on reliability aspects	Provides basic details on customers, their relevance to the firm, and their pending issues.	Stores and manages information related to the testing performed in-house.	Stores all the documentation and information that supports design activity in the field of reliability.	Captures documents, templates and data that support reliability engineers, and the rest of the reliability activity	Provides information on maintenance, troubleshooting, and support. Serves as a window to the customers.	Stores documents that are common to all the classes, such as letters or faxes	Manages the information on the users of the system, their details, location and links with the classes.
<b>Sub Classes</b>	Projects	Supplier	Product Assembly Component Part Item	Customer	Test Request Test Report Failure Report Maintenance Rep	Design Review Environment Anl Loading Analysis FEA Analysis Drawings Product Specs	Reliability doc Fault Tree Anl FMEA Analysis Life time Distrib RBD Docs Reliability Allocation Field test Failure Rep Reliability Costing Analysis	Maintenance & Repair Manual Troubleshooting Guides Service Bulletins Service Parts Information Sheets Field Test Instructions Update on corrective Actions	Letters and Faxes Minute of Meeting General Doc Folder Reference Material	User
<b>File Control</b> <i>(The object is a file.. Documents can be edited and viewed)</i>	<b>YES.</b> Each project is linked to an engineering request document	<b>NO</b> Suppliers are objects not documents. Documents can be linked to them.	<b>NO</b>	<b>NO</b>	<b>YES</b> Each object has a report/document associated	<b>YES</b> This class manages documents	<b>YES</b> This class manages documents	<b>YES</b> This class manages documents	<b>YES</b> Objects are linked to their location in the system	<b>NO</b>
<b>Revision Control</b> <i>(The system keeps track of changes made, by a system of revisions, and life cycle management)</i>	<b>NO</b>	<b>NO</b>	<b>YES</b> Keeping track of revisions and changes in products, parts and components is critical for reliability.	<b>NO</b>	<b>NO</b>	<b>YES</b> Life cycle management is critical in the design activity	<b>SOME docs</b> Some reliability analysis documents might be reviewed throughout product life cycle	<b>SOME Docs</b> Some service support documents might be updated and changed (field test instructions), while some will not (service Bulletin)	<b>NO</b>	<b>NO</b>

Table 5.1 Customized structure of data in the PDM System

### 5.2.2 Failure Data Analyzer

The failure data analyzer allows the user to perform searches and calculation of parameters on field data that has been retrieved from the field. In order to do this the tool connects to the failure and maintenance database, which location can be specified by the user as shown in figure 5.6.

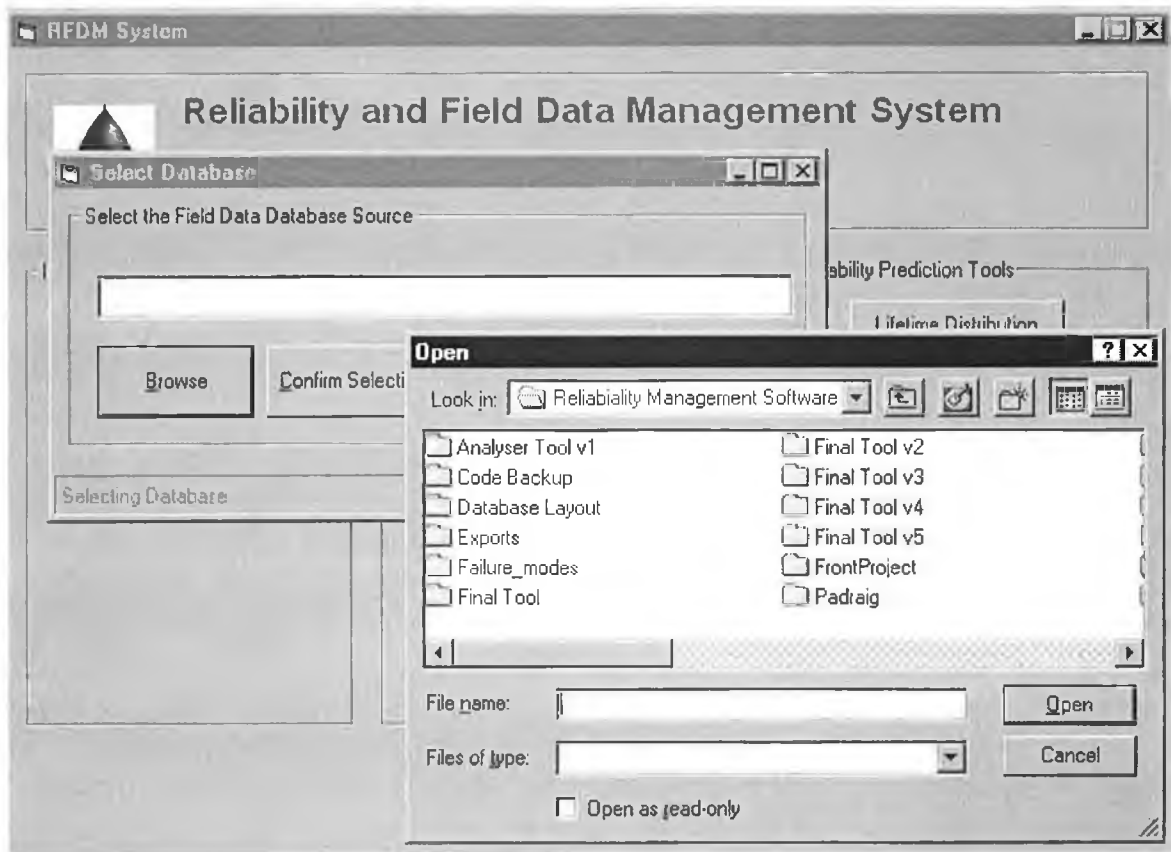

Figure 5.6 Database selection for the failure data analyzer.

The tool searches the failure data in three different ways as follows;

- Top Cost. Retrieves a list of the parts that have failed, sorted by the total cost that the failure of this part has represented.
- Top Frequent. Retrieves a list of the parts that have failed, together with the number of failures for each part, and ranked from higher to lower number of failures
- Define Search. Allows the user to define a search based on different criteria, such as product type, in-service dates, or dealer number.

Figure 5.7 shows the interface of the tool, where the searches can be specified. Parameters calculated based on the data retrieved can be viewed in the performance analysis page as shown in figure 5.8

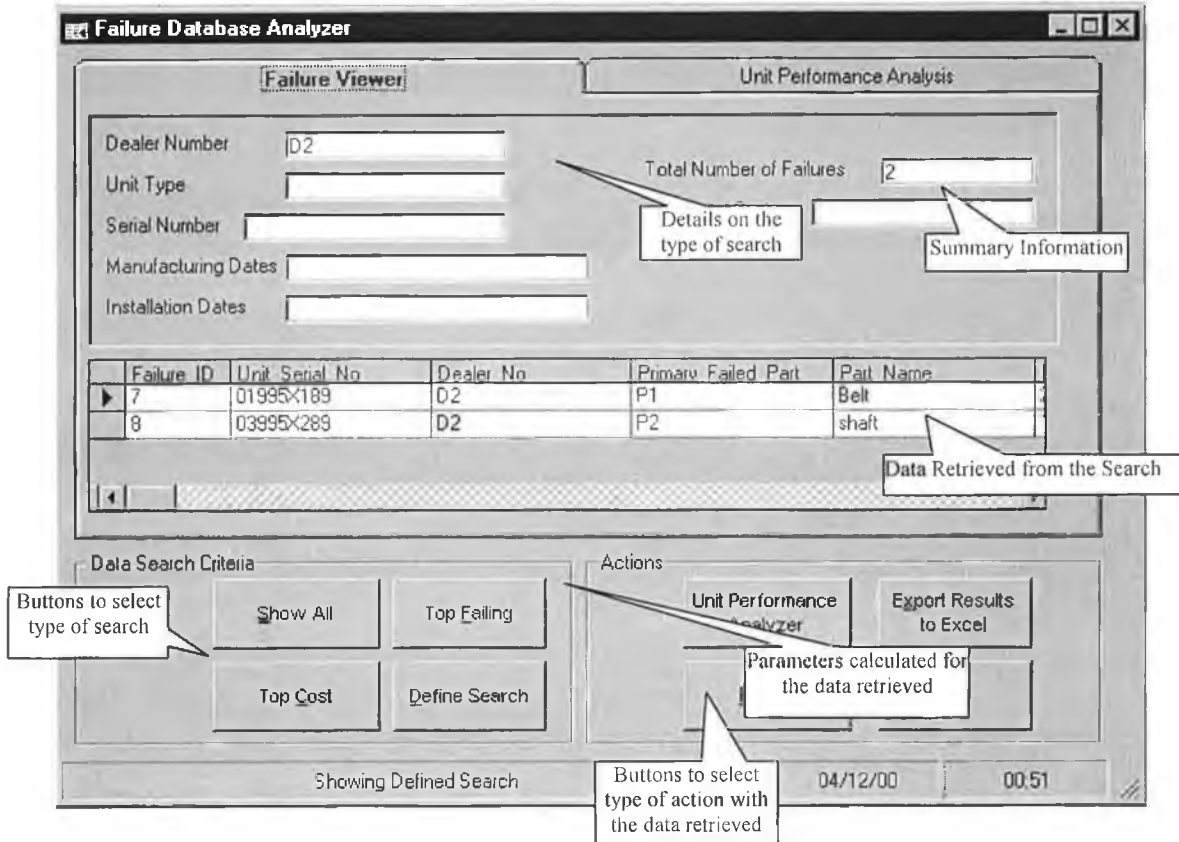

Figure 5.7 Failure Data Analyzer.

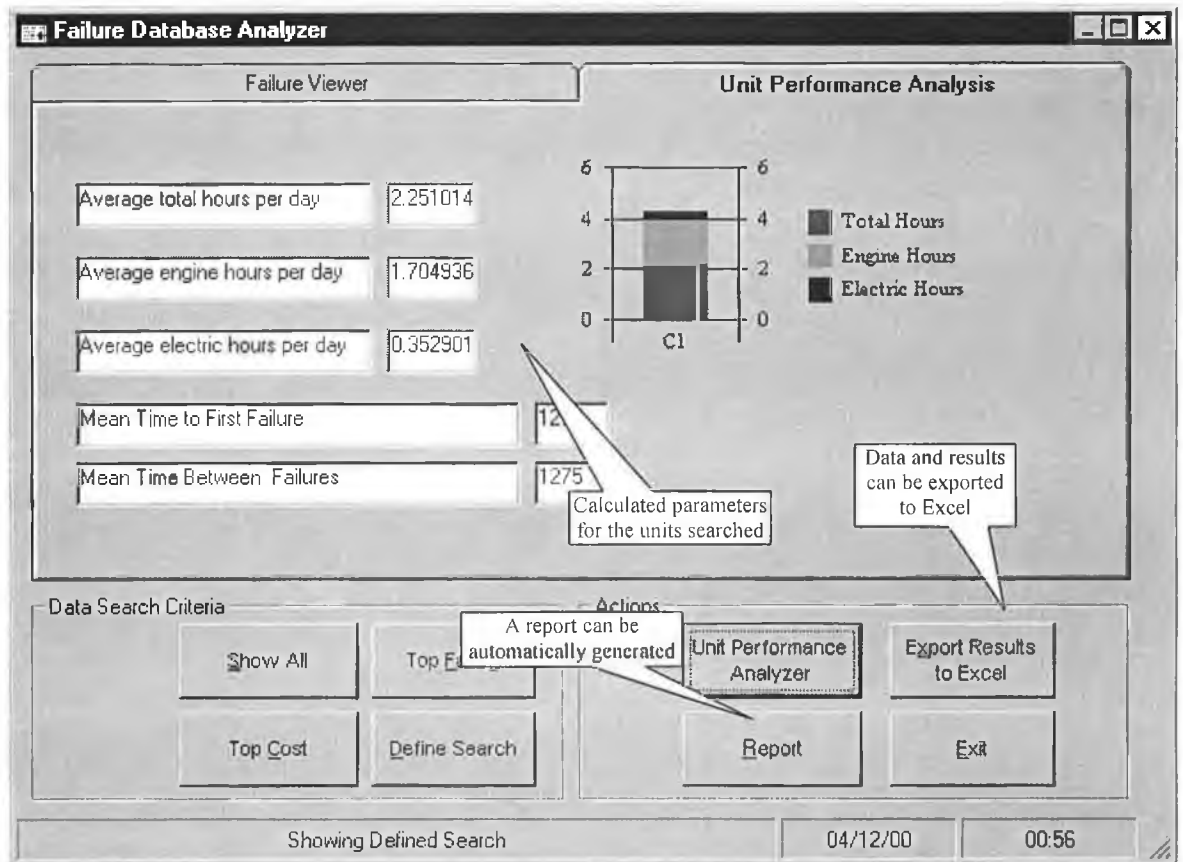
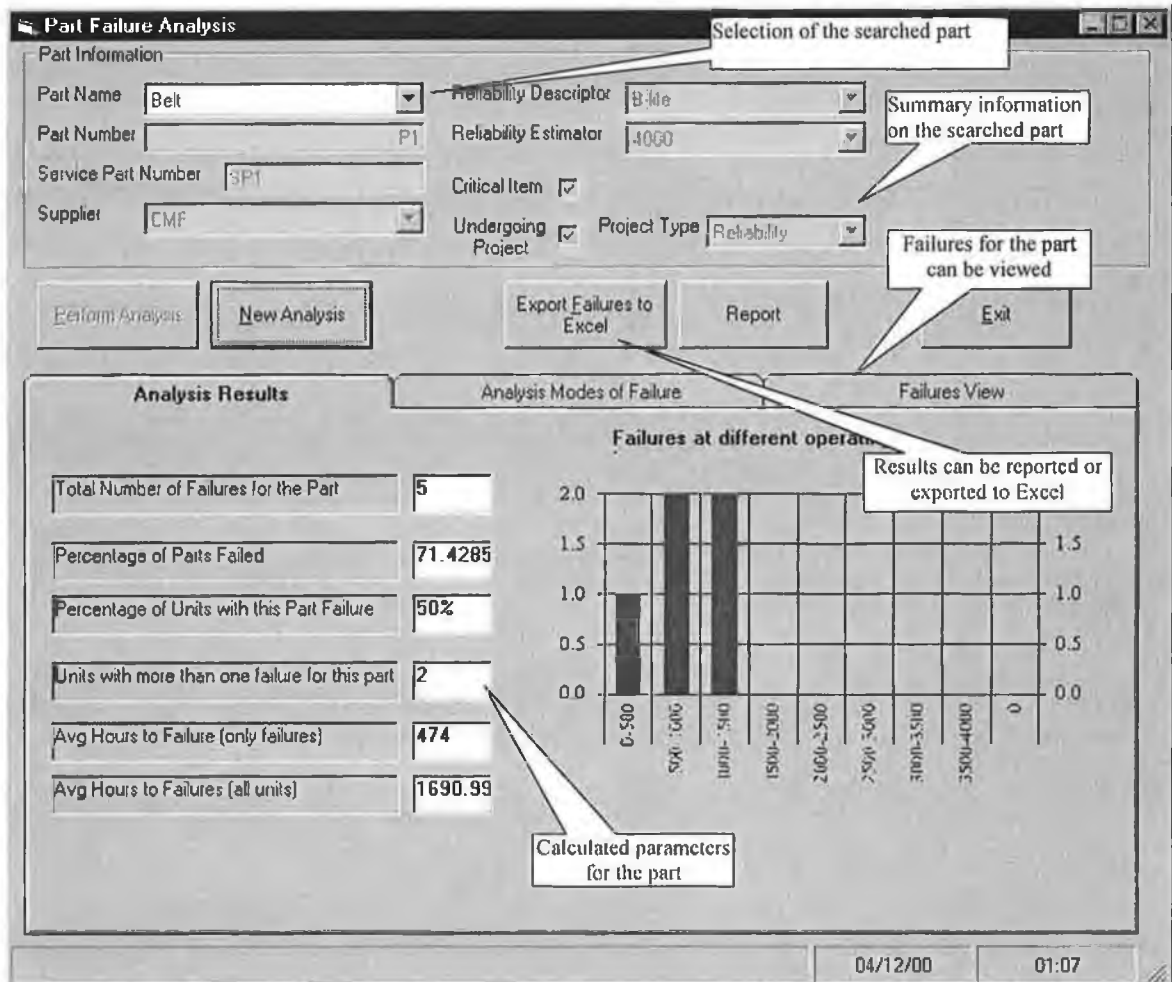

Figure 5.8 Parameters calculated.

## Parts Failure Analysis

By using the parts failure analysis button in the RFDM user interface, a tool is launched that performs analysis on field data, by specifying a particular part or component. This tool also connects to a selected database as shown for the failure data analyzer. The interface of this tool is shown in figure 5.9.



5.9 Parts Failure Analyser.

### 5.2.3 Costing Analysis

The focus of this thesis was on reliability analysis and calculations. The costing part of the project was researched by other authors. Full description and specifications on the costing tool can be found in reference [Her00].

### 5.2.4 Failure Modes Manager

The failure modes manager supports the reliability engineer in specifying failure modes, based on his/her experience and in the FMEA analysis performed on parts and components. By specifying these failures and feeding them onto a database, the reliability engineer ensures that reference is available when needed. These database can be uploaded to the dealers sites, so that they can identify clearly the failure modes of their components and parts, and specify them when entering a failure in their failure and maintenance database. Figure 5.10 shows the layout of the failure modes manager.

The screenshot displays the 'Failure Mode Database' application window. At the top, there is a table with two columns: 'Failure ID' and 'Failure Definition'. The first row contains the values '1' and 'Belt Cracks'. Below the table, the interface is divided into three tabs: 'Failure Information', 'FMEA', and 'Fault Tree Analysis'. The 'Failure Information' tab is currently selected and contains several input fields: 'Part Name' (with the value 'Belt'), 'Part Number' (with the value 'P1'), 'Failure Type' (with the value 'Wear-Out'), and a checkbox for 'Undergoing Project' which is unchecked. A 'Rating details' section includes four numerical input fields: 'Severity Number' (4), 'Criticality Number' (6), 'Detectability' (9), and 'Failure Rating Number' (5). To the right of these fields is a 'Failure Description' text area containing the text 'Failure due to long hours on belt, and to inadquate maintenance'. Below the description are two empty boxes labeled 'Picture of Failure'. At the bottom of the window, there is a row of buttons: 'AddNew', 'Save', 'Undo', 'Edit', 'Delete', 'Find', and 'Done'. Below these buttons are navigation arrows and a status bar indicating 'Failure 1 of 8'.

Figure 5.10 Failure Modes Manager.

### 5.2.5 Reliability Prediction Software

Different software packages for reliability prediction can be accessed through the RFDM system. This software packages are used for performing some of the reliability analysis and calculations that have been described in chapter two. Figure 5.11 shows the Weibull software, which is used in reliability predictions based on lifetime distributions.

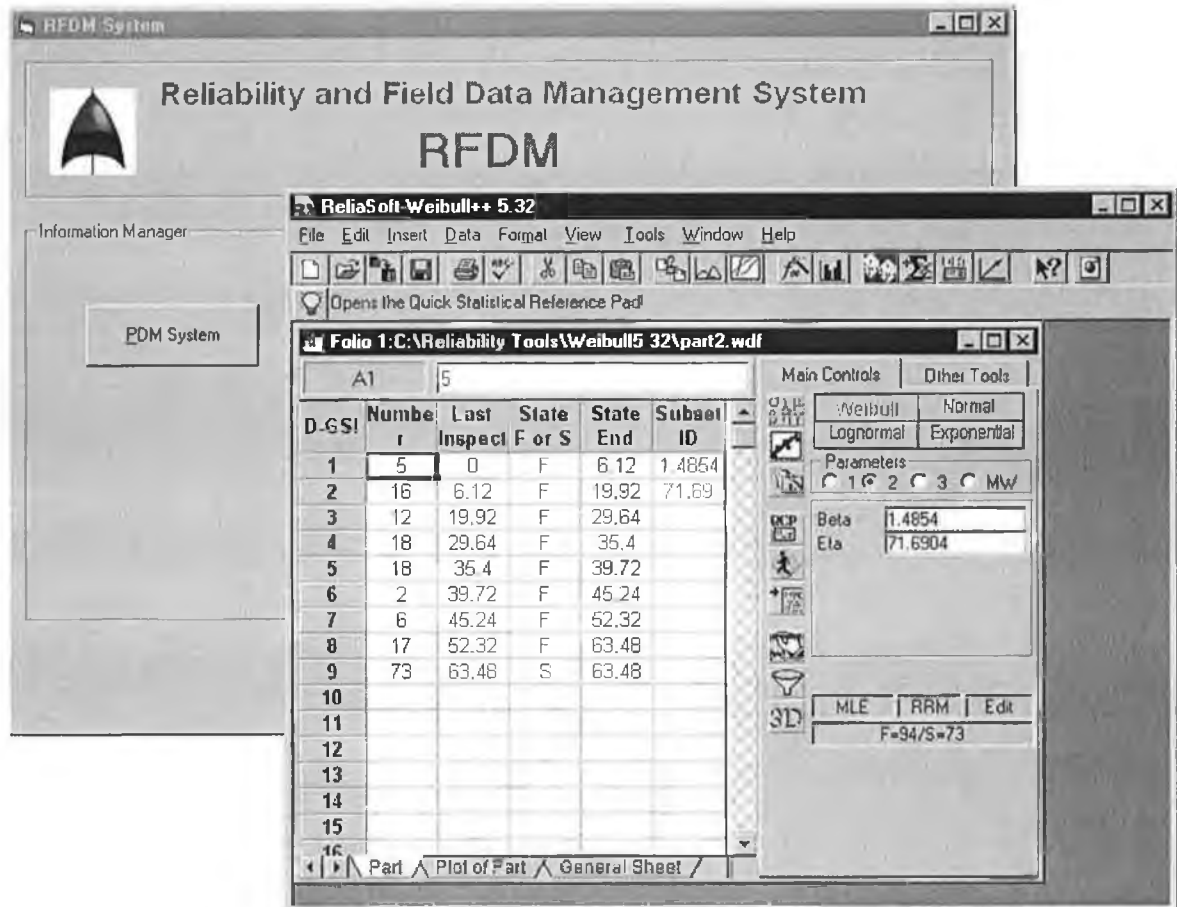

Figure 5.11 RFD System launches reliability prediction software.

### 5.3 Performing Field Data Reliability Analysis

The process of field data analysis, both in cost and reliability has been conceptually described in chapter four. Field data is transferred to the reliability engineer database through the internet. A standard database to perform this type of analysis has been developed in Microsoft Access. Data from this format can be exported and imported to the different tools that are used in the RFD, i.e. the information manager and the different prediction tools. The field data analyzing tools can connect directly to the specified database. The results of the analysis can be then exported to Excel files or to report format, and stored in the information manager. The set of steps to be followed when using the RFD system for this purpose is shown in figure 5.12.



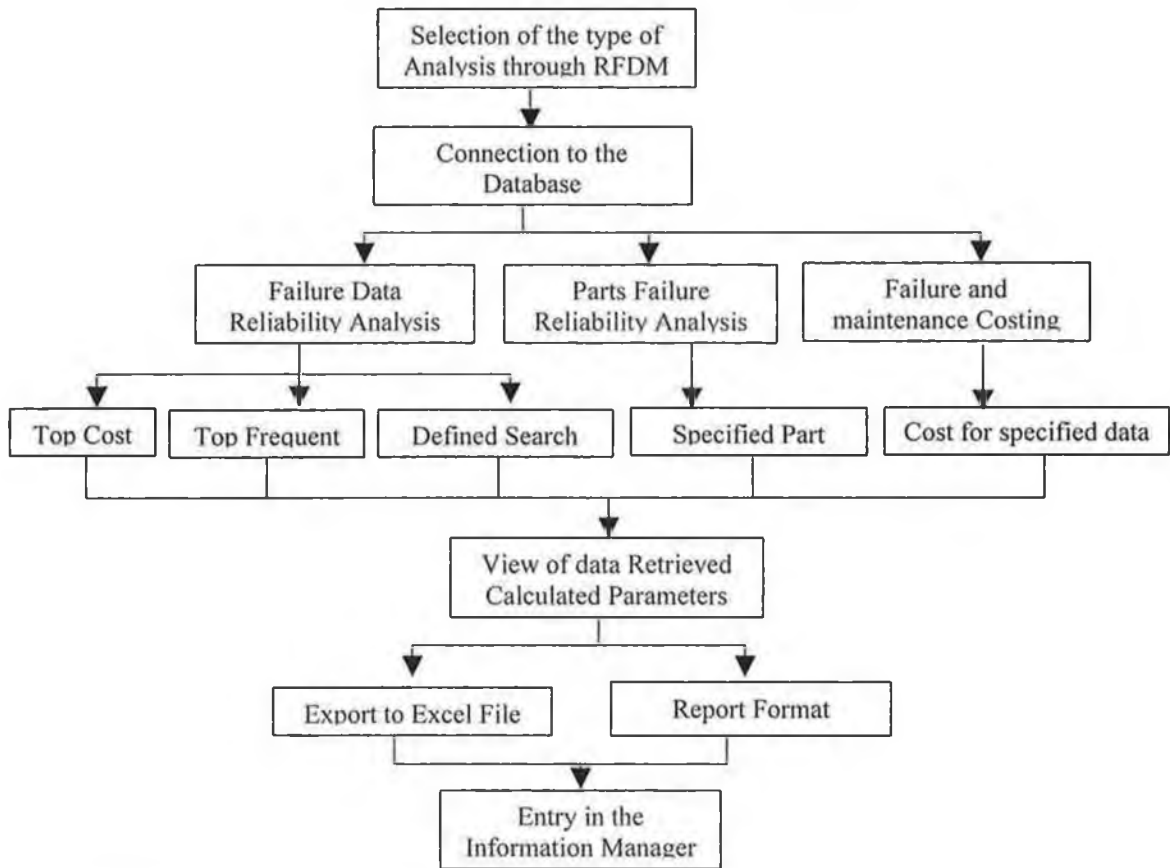

Figure 5.12 Steps to perform field data analysis.

### 5.3.1 Searching Parameters

In figure 5.21 a defined search parameters is specified for doing reliability analysis on a set of data

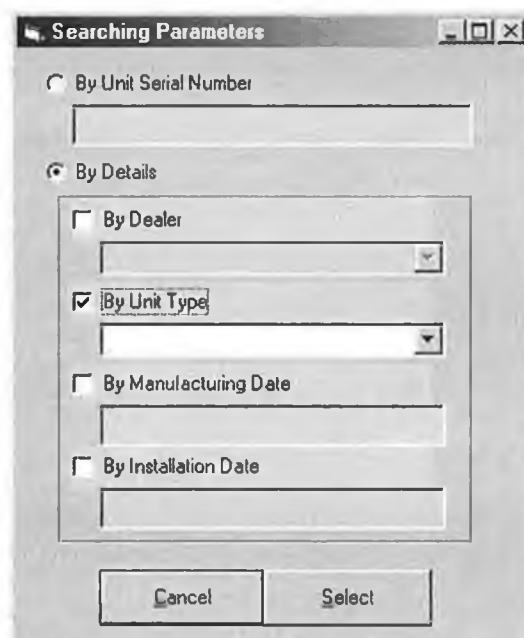

Figure 5.13 Searching Parameters for Failure Analysis.

Dealer and unit type can be picked from a list, while the dates can be selected from a calendar type screen, as shown in figure 5.14.



5.14 Selecting different dates for search.

### 5.3.2 Calculation of Parameters

Once the parameters of search are specified, the tool retrieves the failures according to that information, and calculates a number of parameters that give some reference on the reliability performance of the units searched. Figure 5.15 shows the search for units of type SL 100.

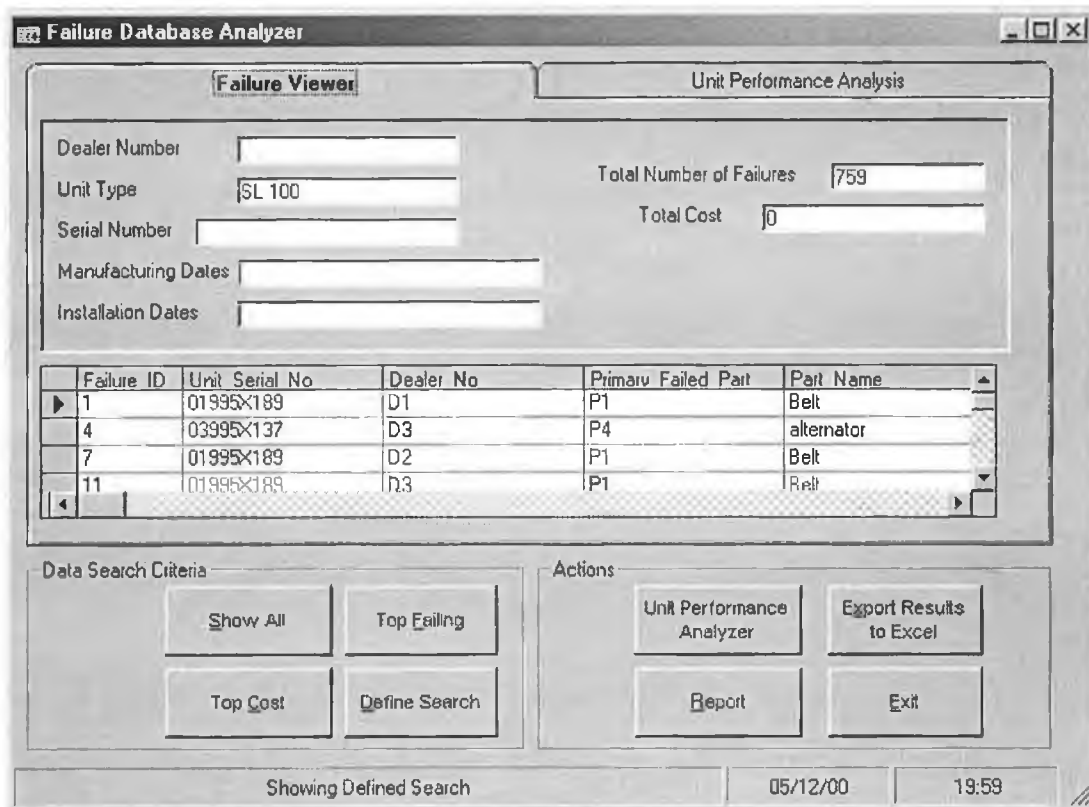

Figure 5.15 Search for units SL 100, with failures.

The tool gives options to export data to different formats. An Excel format will allow the user to perform further analysis or calculations. In any case, the file generated is then added to the information manager, in the class reliability as shown in figure 5.16.

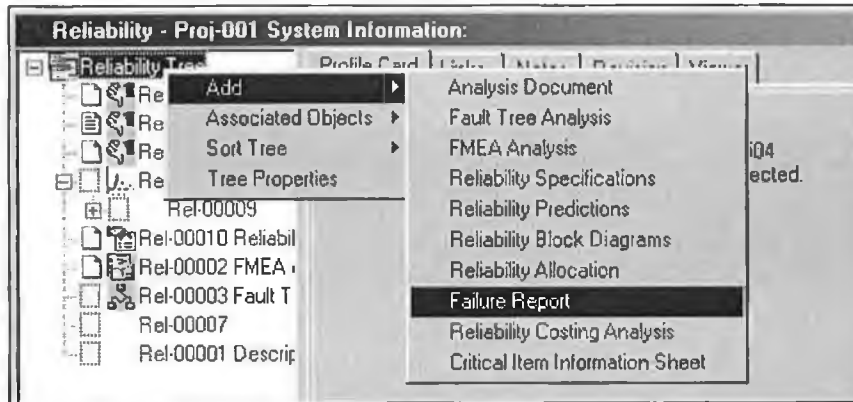

Figure 5.16 User adds failure report to the information manager.

### 5.3.3 Documenting the Results

When adding the document, the user can specify the summarized information by filling the fields in the failure report profile card.

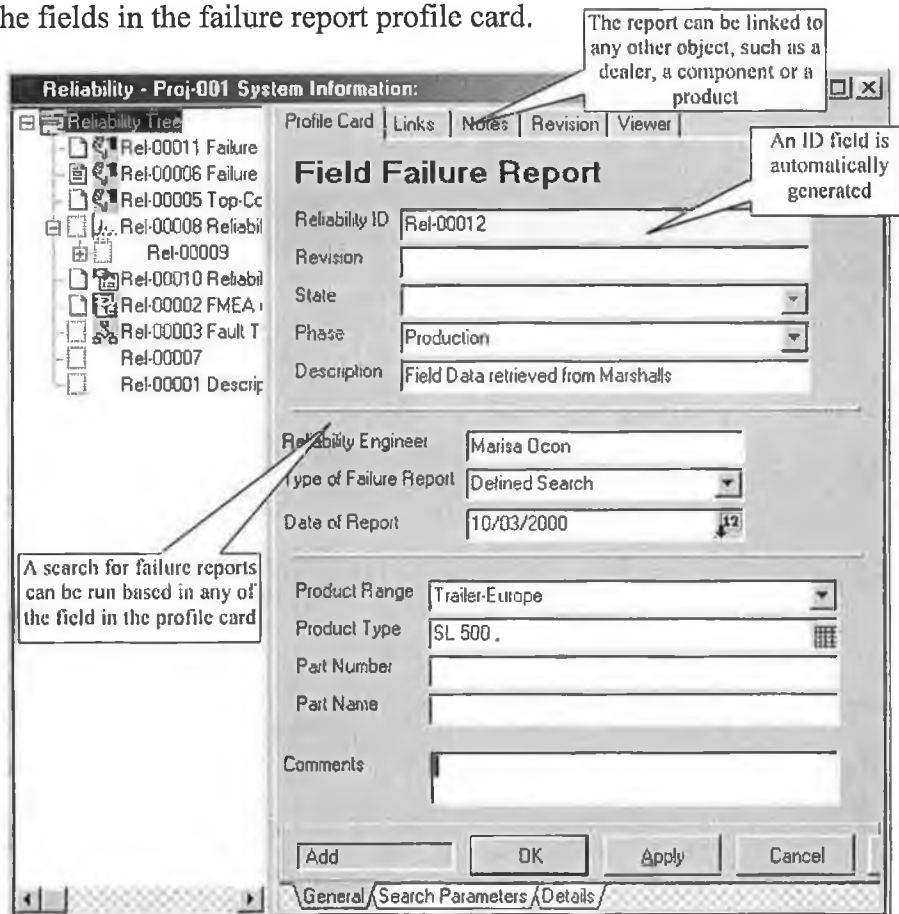

Figure 5.17 Field Failure Report information pages in the system.

When filling in the different fields, the user can make use of support features, like lookup tables, or reference lists to other classes, e.g. when selecting the product type, data from the products class is automatically displayed for the user to select, as shown in figure 5.18.

Product ID	Revision	Class
1		
2	SL 100	
3	SL 200 50	
4	SL 500	
5	SL 300 50	
6	SL 200 30	

Figure 5.18 Product type selection feature.

The searched parameters, and a summary of the findings can be also added in a second information page, as displayed in figure 5.19.

**Reliability - Proj-001 System Information:**

Profile Card | Links | Notes | Revision | Viewer

**Searching Parameters**

By Unit Serial Number:

By Unit Type:

By Part Number:

By Dealer Number:

By Date of Failure:

By Date of Manufacture:

By Date of Installation:

By Failure Modes:

**Summary of findings**

High number of failures for belts and electric motor.  
Units have repeated failures for these parts.  
Percentages are over the average.

Search parameters information page

Add OK Apply Cancel Help

General Search Parameters Details

Figure 5.19 Failure report search parameters and conclusions.

The file is finally added to the system by specifying its location. If the failure report was released, the file would be added to the vault. In this case, access would be secured and data would be encrypted. The revision system would be initiated.

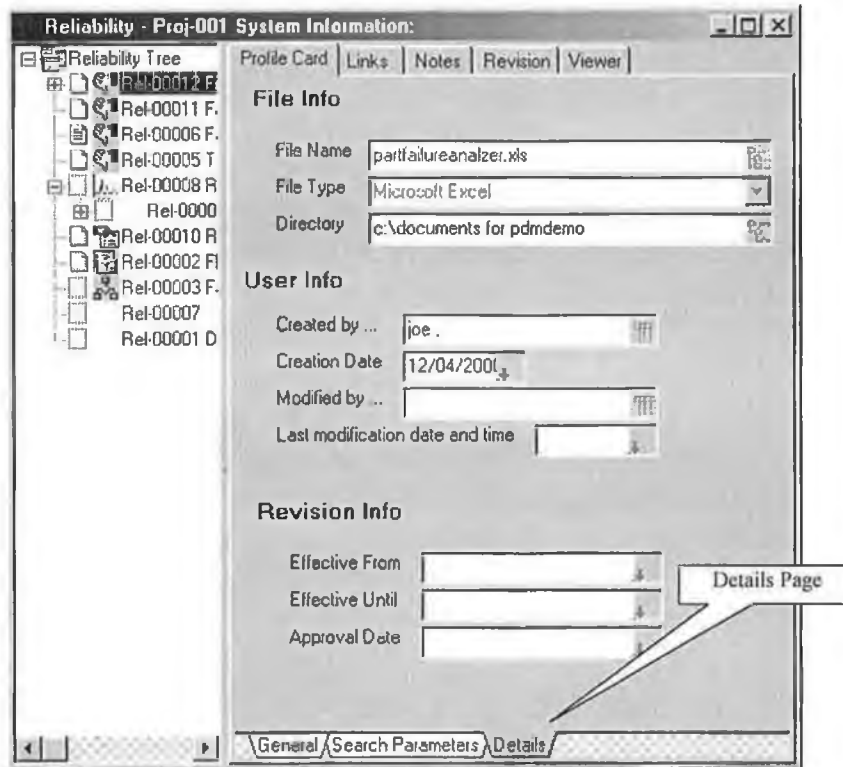

Figure 5.20 Failure Report file information, user information and revision information.

From this point on, all the users of the system can access the information gathered in this document (given they have viewing access of this class). For example a user might be interested in retrieving all the failure reports on a particular product type. By searching the system with that parameters as shown in figure 5.21, the user will retrieve the specified documents included the one that has just been added. Once the search is run and the documents have been retrieved, the user has access to a number of features;

- view all the summarized information through the profile card;
- view the actual file through the viewer page;
- add notes to the failure report;
- view and access the documents that are related (linked) to the failure report.

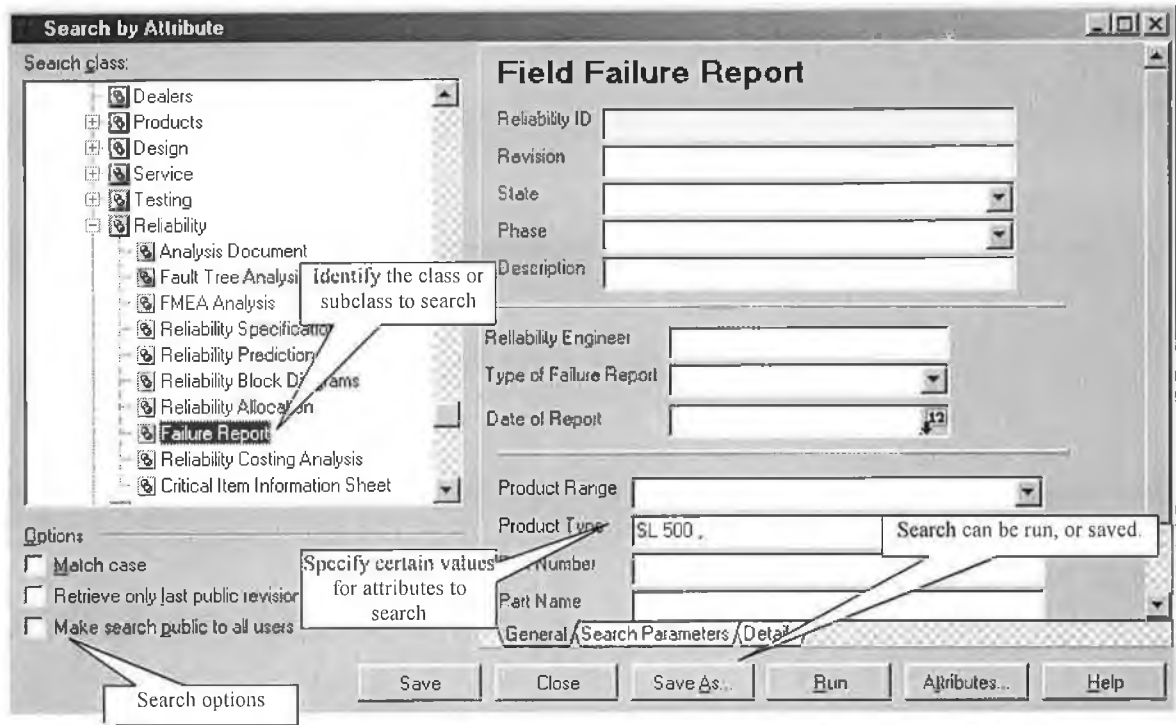

Figure 5.21 Searching for failure reports.

The viewer page for the failure report is shown in figure 5.22

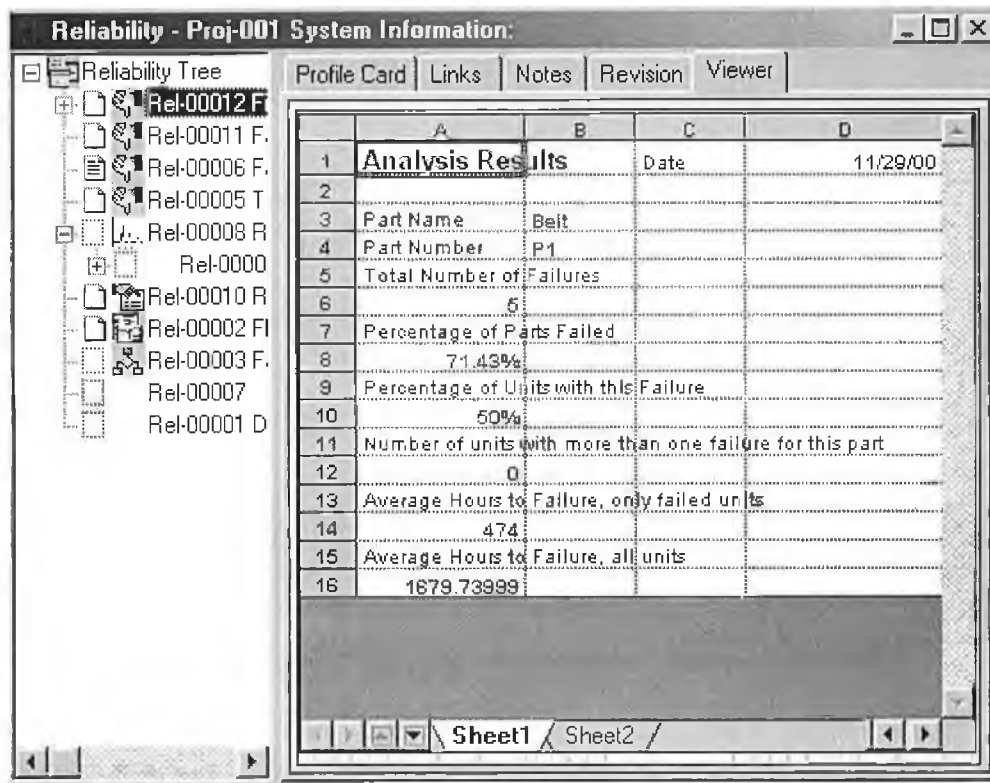
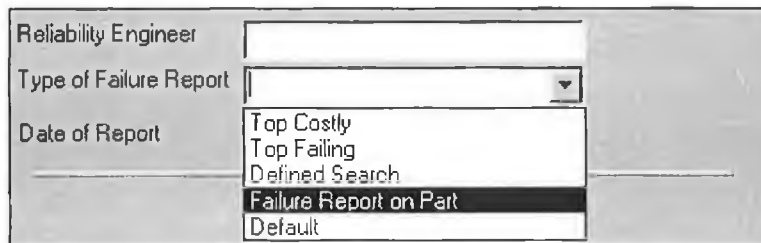

Figure 5.22 Viewer page for failure report.

The parts failure analyzer allows the user to perform reliability analysis on field data but for specific parts or components. Once the analysis is produced, the information can be dealt with in the same manner as has been shown. In this case, the type of field data analysis report will be specified to: failure report on part, as shown in figure 5.23. The part number will be entered in the parameter information.



The image shows a software interface with three input fields on the left: 'Reliability Engineer', 'Type of Failure Report', and 'Date of Report'. The 'Type of Failure Report' field is open, displaying a dropdown menu with the following options: 'Top Costly', 'Top Failing', 'Defined Search', 'Failure Report on Part' (which is highlighted with a dark background), and 'Default'.

Figure 5.23 Specifying a failure report on part type of report.

In summary, field data can be consistently analyzed by using the tools developed. Different types of analysis can be made. Files automatically generated with these tools are then added to the information manager. A specific subclass of the class reliability stores this type of files. Summarized information on the analysis, searched data and findings can be added to the profile card of the report. Once added, users can retrieve it through various searches. They can also view it, and access the summarized information.

## 5.4 Failure Report and Corrective Action System

To ensure that the relevant personnel is informed on failures, failure reports can be brought through a workflow designated by failure reporting process. The same applies to any corrective actions that are implemented, and that would generally result of a failure report process. For that purpose, the corrective action process is used. As specified in chapter four, when the failure report process is initiated, the reliability engineer will generate a failure report that will be brought throughout the workflow path.

### 5.4.1 Failure Report

The generated failure report, can be the result of field data analysis or in-house testing and checks. In this last, case the reliability engineer will use the template that he can retrieve from the system to specify the failure information as shown in figure 5.24.

Documents - Proj-001 System Information: Profile Card | Links | Notes | Viewer

Documents Tre

- Ref-0001
- Ref-0001
- Ref-0001
- Ref-0001
- Ref-0001
- Ref-0001
- Folder 01
- Ref-C
- Ref-C
- Ref-C
- Ref-C
- Folder 01
- Ref-C
- Folder 01
- Ref-C
- Ref-C
- Ref-C

Title			
Author		Position	
Date		Location	
Purpose			

Product Type		Part Number		Part Name
Dealer		Dates		
Type				
Other				

**1 Define the reasons for the Failure Report.**

*(Summary of motivation, i.e. customer complains, research & development, warranty analysis, costing analysis .... etc)*

**2 Define the scope for the Failure Report**

*(Summary of the information that was looked at, describe the parameters for searching this information)*

**3 When Searching a component or part, describe the failure modes, their environmental specification, and possible cause.**

**4 Describe summary of findings**

**5 Add any other information considered relevant**

Figure 5.24 Template for failure report.

### 5.4.2 Failure Report Process

The process is generated by choosing it from the workflow menu as shown in figure

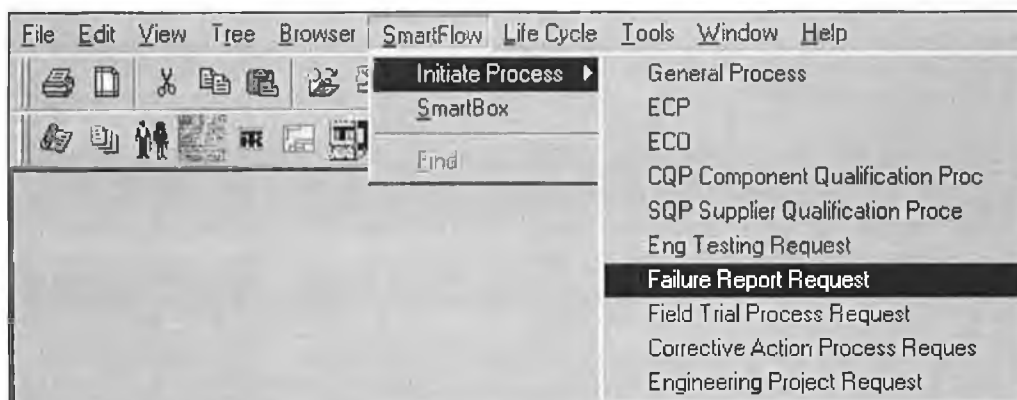

5.25 Initiation of failure report process.



The failure report also has customized pages of information, and a profile card that is passed on together with the documents or objects that are the subject of the process.

This is shown in figure 5.26

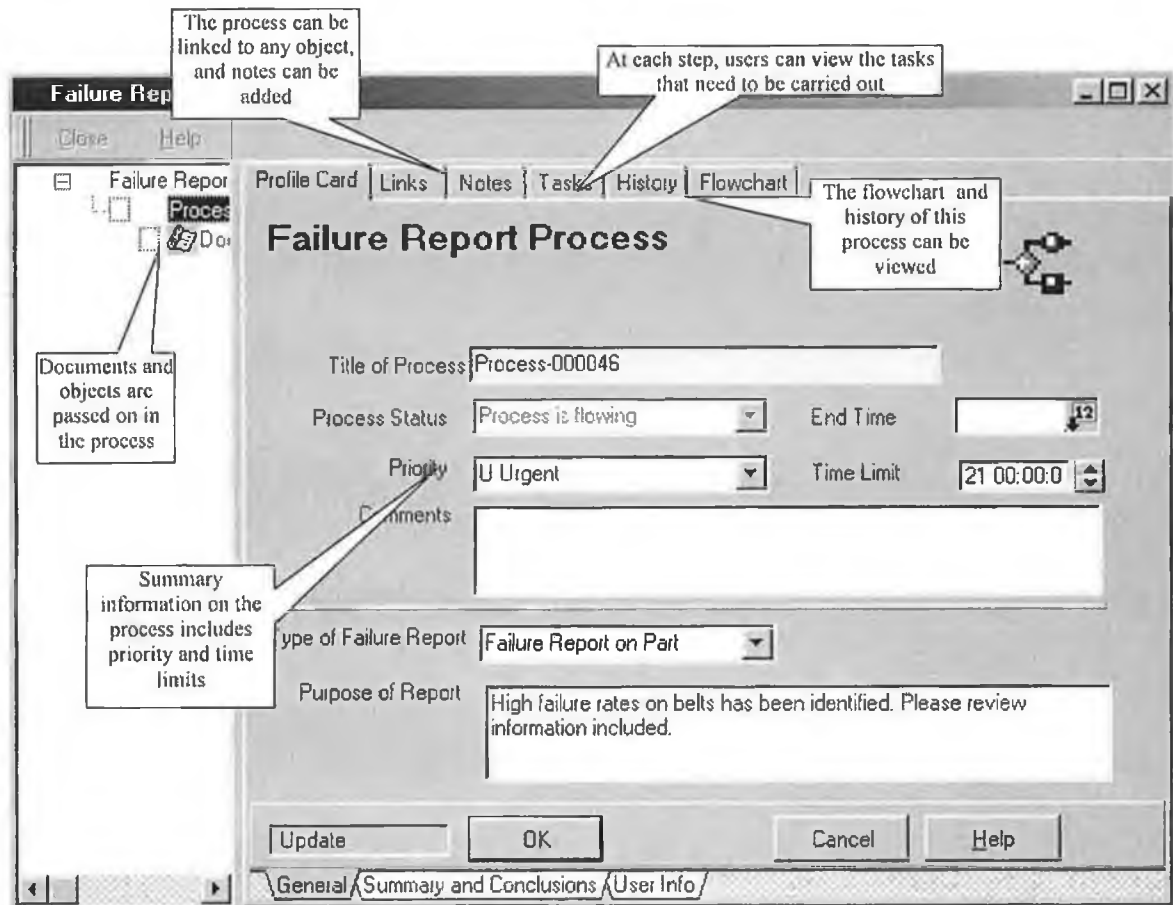

Figure 5.26 Failure report process pages of information.

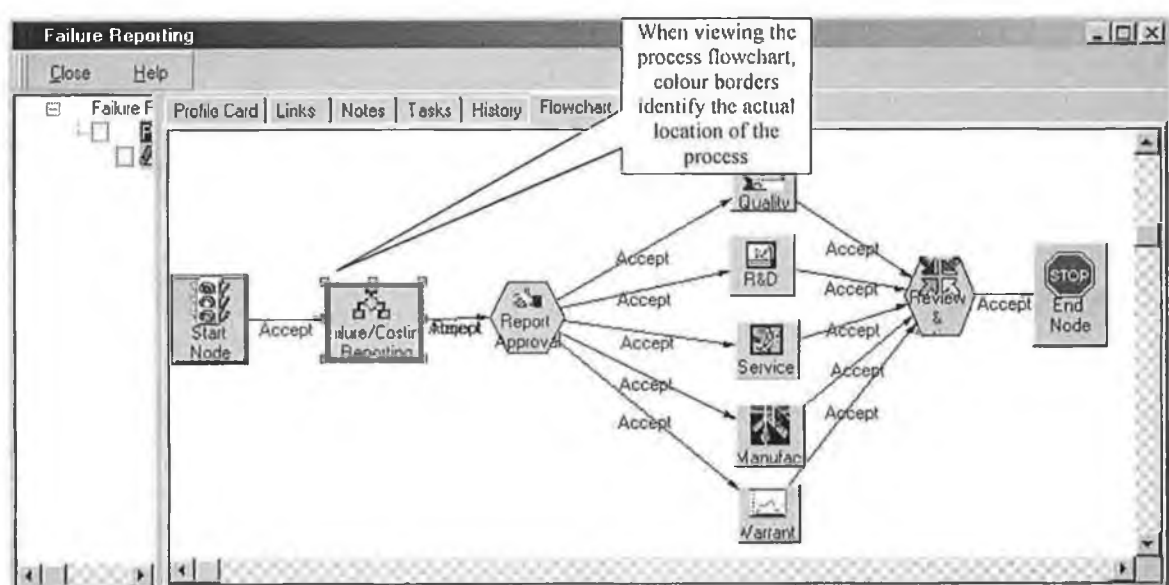

Figure 5.27 Flowchart for failure reporting process.

When users receive the process in their workflow mailbox they can open it, view the information linked to it, the tasks to be performed, the time allocated to perform them, and the history of the flowchart, as shown in figure 5.26 and 5.27. Figure 5.28 shows the tasks window where the reliability engineer views what needs to be done.

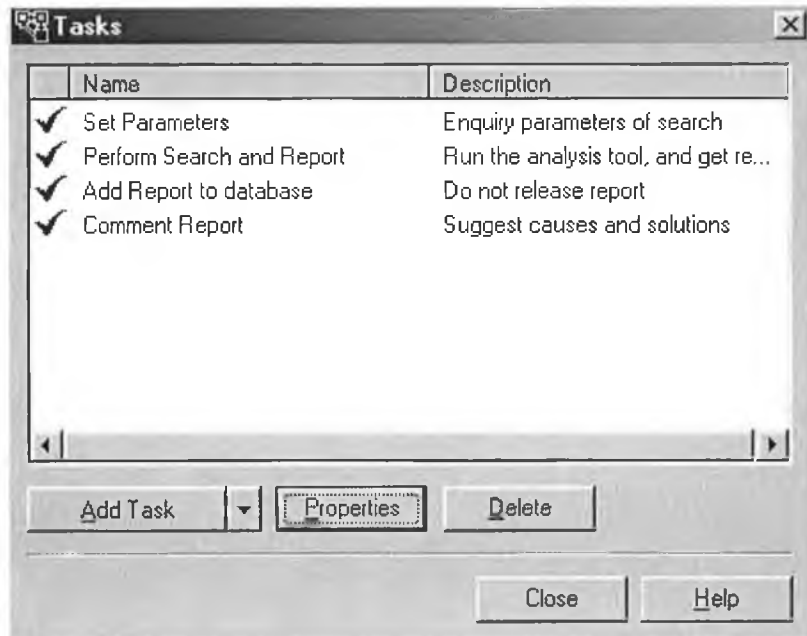

Figure 5.28 Tasks of the reliability engineer.

Once the tasks have been performed, users accept the process and it is automatically sent to the next user in the flowchart. Paths are also designed for cases of rejection. When the failure report process has been completed, all the designed personnel has received the information on the report, and has reviewed it and analyzed it. Their comments and suggestions have been added to the process for further review.

#### 5.4.3 Corrective Action Process

In many cases a failure report process will result in a corrective action process. This process is initiated after failure analysis has been carried out by assigned engineers, and a proposal of solution has been presented. The operation of the corrective action process is similar to the failure report process. Initiation of the process is carried out through the workflow menu as shown in figure 5.29.

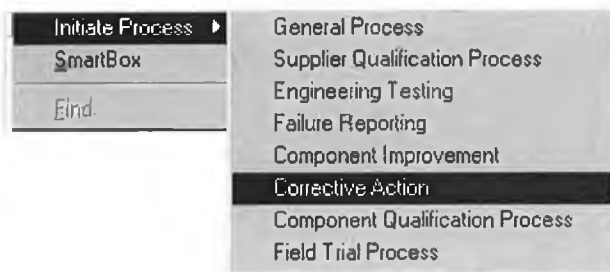

Figure 5.29 Initiation of a Corrective Action Process.

The front page that presents the process summarizes information on the process, and includes status, importance of time limits. This page is shown in figure 5.30

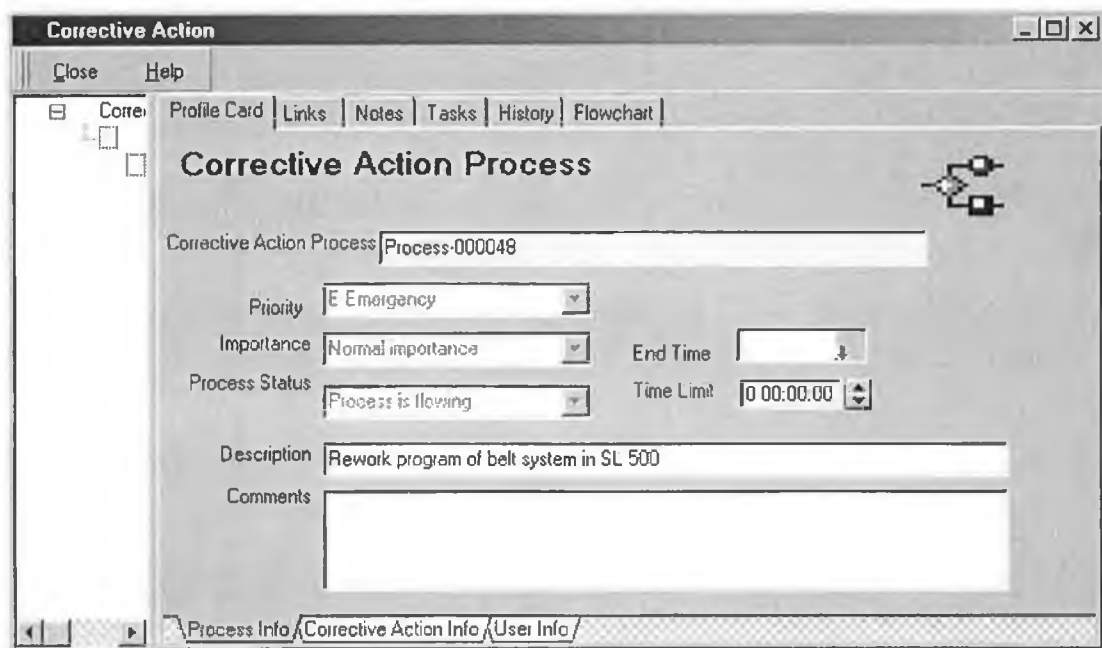

Figure 5.30 Corrective action process general information.

Specific information on the action itself is recorded on a second page of information as shown in figure 5.31. There is also a flowchart specified for this workflow, and the information is brought through it much the same as in the failure report process. In this case users have to review the action, comment it, and approve it from their specific area, e.g. quality, reliability or design. Each user is assigned a number of tasks and a time limit to perform these tasks.

The screenshot shows a software window titled "Corrective Action" with a menu bar containing "Close" and "Help". Below the menu bar is a tabbed interface with tabs for "Profile Card", "Links", "Notes", "Tasks", "History", and "Flowchart". The "Profile Card" tab is active, displaying the following information:

- Actions affect...**
  - Affected Units: SL 500
  - Affected Parts: Belt System
- Reasons for Action:** High Failure Rate of belts detected. Belt system is being overstretched by pulley.
- Description of Action:** Introduction of a spring system onto the pulley in the belt system.
- Purpose of Action:** Spring system reliefs tension of belt
- Need Test
- Need Repair Kit
- Part Number for Kit: ZS220384

At the bottom of the window, there are buttons for "Update", "OK", "Cancel", and "Help". A status bar at the very bottom shows "Process Info", "Corrective Action Info", and "User Info".

Figure 5.31 Corrective action specific information.

#### 5.4.4 Corrective Action Update and Feedback

As well as this, as the processes flows through, a corrective action entry in the database is created. This entry is stored in the service class. The information on the corrective action is summarized there. All the relevant files such as test instructions, or fitting instructions are added to this entry. The service class is generally the window of the system to dealers. Through the service class dealers will be kept informed on the corrective actions that are being implemented, and will be able to access all the information that they required for carrying out these actions. Figure 5.32 shows how a corrective action can be added to the system through the service class menu.



Figure 5.32 Adding an update on corrective actions to the service class.

The update on corrective actions profile card is shown in figure 5.33. This class has been designed with the purpose of informing dealers.

**Service - Proj-001 System Information:**

Service Tree | Profile Card | Links | Notes | Revision | Viewer

### Update on Corrective Actions

Corrective Action ID: CA-000002

State: New

Corrective Action Title: Spring pulley kit for belt system

Description:

Product Range: Trailer-Europe

Product Type: SL 500

Part Name: Belt system

Part Number:

Comments: Use only in units with cycle centy option.

General / Summary of Action / Details

Figure 5.33 Update on Corrective Actions.

The second page of information summarizes the information on the action. Files with instructions can be added. Recommendations can also be add. Also the watch out field points out critical issues, and requests feedback on them.

**Service - Proj-001 System Information**

Profile Card | Links | Notes | Revision | Viewer

Reason for Action: High failure rate of belt system caused by over-strech in the pulley

Purpose of Action: Avoid over stretching

Description of Action: Spring system added to the pulley

Field Rework Required  
 Field Maintenance Required  
 Need check

Check Title: Tension measurement of belt system

Need Kit      Kit part Number: Zs934920

Watch out for: When kit used, check periodically state of spring and feedback if any cracks appear.

Requests for feed back can be included

Update    OK    Cancel    Help

General / Summary of Action / Details /

Figure 5.34 Update on corrective action summarized information.

Feedback from the corrective actions has the means to get back to the organization efficiently, provided there is good collaboration and interaction with the dealer. Figure 5.35 shows how a dealer has introduced a comment as requested in the corrective action object.

**Service - Proj-001 System Information**

Profile Card | Links | Notes | Revision | Viewer

Creation Date	Created by ...	Modified by ...	Last modification date and time	On 0
1	12/05/2000 01:0	dealer	###0000	

One of the springs used has cracked after 50 hours of operation. I am sending it back to TK for further analysis. The rest seem to be fine.

Figure 5.35 Feedback from the dealer through the notes page

## 5.5 Critical Item Reliability

The purpose of Critical Item Reliability is to identify critical items. Critical items are defined as items or components that are likely to be sources of unreliability, or whose failure can significantly affect reliability, safety or repair/replacement costs. The purpose of critical item reliability is to identify these components through established rules or guidelines, and assure that engineers and users are aware of this condition, so that precautions can be taken. A critical component will, in general, require special attention when used in a design process, when being assembled, and also when being maintained. The list of critical items must be consistent, and must come across the organization. The process of specifying critical items and publishing this information is done through the information manager and will be implemented following the specifications reviewed in chapter four. The different steps are shown in figure 5.36.

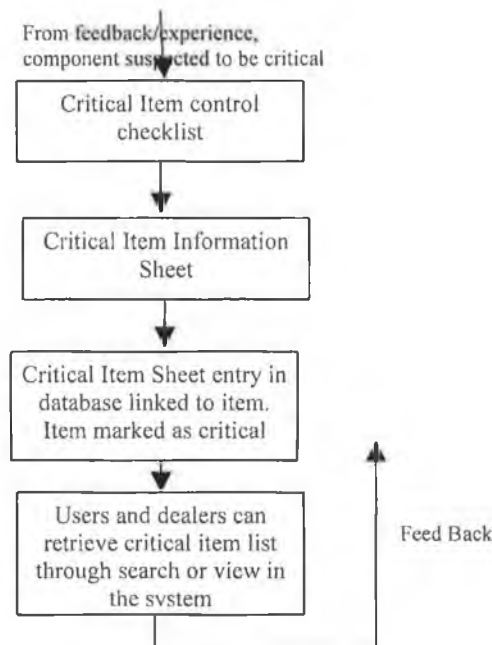

Figure 5.36 Steps for critical item reliability.

### 5.5.1 Critical Item Control Checklist

The reference material class stores a checklist for critical item identification and rating, and a template that can be fill in when identifying a component as critical. The reliability engineer will retrieve this template through the information manager and fill in the required information. By systematically using this checklist he/she will decide upon criticality. If the item is proven to be critical he/she will add this document to the system and mark the component as critical to feedback the rest of the users.

Title	Critical Item Sheet			Revision	
Author	Marisa O'Connell	Position			
Date	11/2000	Location	R&D Galway		
Product	SL 200	Part Number	772527	Part Name	Blower Shaft
Purpose					
Score	Identification of Critical Items			Score (0 to 10)	
	High Value Components			6	
	New Technology or Processes			2	
	Limited Life Items (wearout before nominal end of life)			6	
	Reliability sensitive parts (high failure rates from historical experience)			0	
	Single Source or custom components			10	
	Single Failure Points (features that cause total loss of operating capability)			10	
	Total Score for the item (out of 60)			32	
Control Checklist	Has Failure Mode Analysis been considered?				YES
	Have compensating features been considered in design?				NO
	Have reliability improvement options been considered?				YES
	Are any significant tolerances for manufacturing or performance required?				YES
	Are review intervals to control critical items?				YES

**1 Identification of the Problem**  
 The steel shaft located in the blower's assembly, was reported to fail in two different units, in September 98 for the first time. Some concern was shown because some parts of the assembly had been redesigned some time ago. A steel shaft failing is a major "customer impact" problem, since the unit is not able to perform its operation and because it is a non-expected kind of failure.

**2 Description of failure**  
 steel shaft seizing, with a fracture surface fairly clean and perpendicular to the shaft axis. The point of fracture is located in the control box bearing assembly, in the inner part of it, at the point where the shaft thickness changes to accommodate the bearing radius.

Figure 5.37 Critical Item Information Sheet.

**5.5.2 Critical Item Entry in Information Manager**

The critical item information sheet is added to the system, by storing it in its specified location in the reliability class, as shown in figure 5.38.

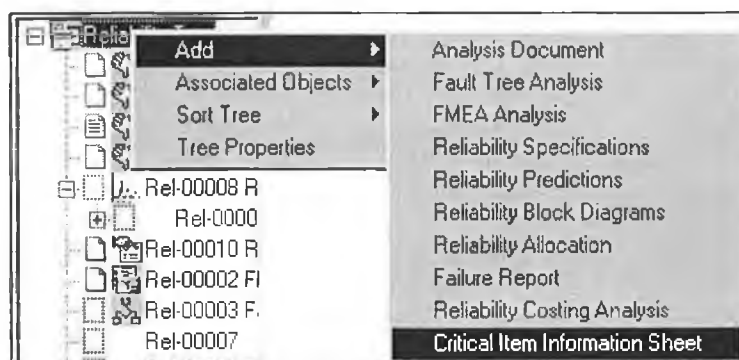

Figure 5.38 Adding a critical item information sheet.



As with any other object that is added, a number of fields are filled in, in the customized information page. This helps users to quickly get the relevant information, and to have a number of parameters for searching criteria. The profile card view for the critical item entry is shown in figure 5.39.

The screenshot shows a software window titled "Reliability - Proj-001 System Information". On the left is a "Reliability Tree" with a list of items including "Rel-00014 C", "Rel-00012 Fi", "Rel-00011 F.", "Rel-00006 F.", "Rel-00005 T", "Rel-00008 R", "Rel-00000", "Rel-00010 R", "Rel-00002 Fi", "Rel-00003 F.", "Rel-00007", and "Rel-00001 D". The main area is titled "Critical Item Information Sheet" and contains the following fields:

Reliability ID	Rel-00014
State	New
Description	Critical Item with score 32
Part Name	Blower Shaft
Part Number	75428
Product Type	
Product Range	Trailer-Europe
Reliability Engineer	Tom McPhelin
Comments	Few failures, but very critical and damaging.

At the bottom of the window, there are tabs for "General" and "Details".

Figure 5.39 Critical Item Information Sheet in the information manager.

And consequently, the component specified is market as critical in its profile card as shown in figure 5.40.

The image shows a small rectangular box containing two checkboxes:

- FMEA Performed
- Critical Item

Figure 5.40 Component is marked as critical in its profile card.

### 5.5.3 Critical Items List

The fact that a component is critical or not, is stored in the field critical items of the components class. This field is a simple checkbox. In order to retrieve which items are critical, users can build a view in their system that will dynamically search for those items where this checkbox is ticked as shown in the next figure. In this way, the user has continuous access and feedback on which items are critical, and can retrieve the information sheet for reference.

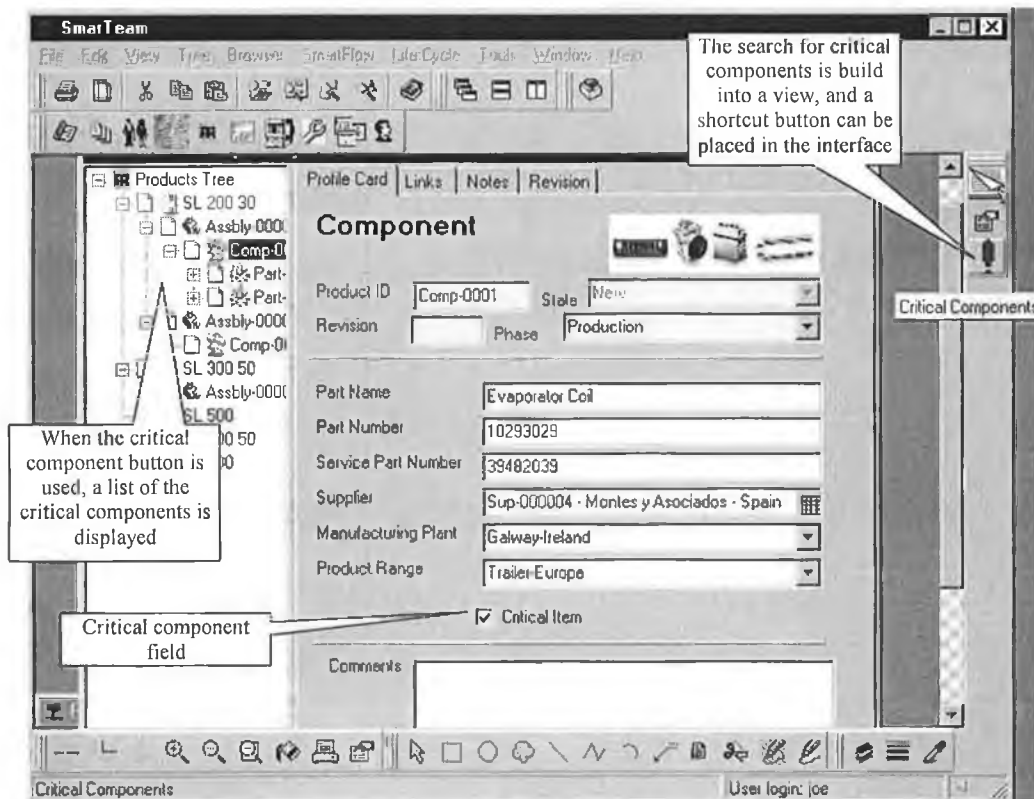

Figure 5.41 Critical Items Listing.

### 5.6 FMEA Analysis

FMEA Analysis has been recognized as one of the most valuable tools of reliability in design. One of the major benefits of performing consistently FMEA analysis on assemblies and components, is that these documents can be used for reference in many other activities. FMEA are used for component qualification processes, for designing maintenance strategies, for creating troubleshooting guides or for supporting other documents such as reliability predictions and specifications.

FMEA documents are therefore a very important class in the RFDM system. The documents are stored in the class Reliability as shown in figure 5.42.

Figure 5.42 FMEA Analysis profile card.

The profile card captures relevant information such as the type of FMEA or the motivation for performing the analysis. When a FMEA is performed on a component or assembly, a checkbox is ticked in the product profile card, so that a user can know that the FMEA exists and search for it. This is shown in figure 5.43.

Figure 5.43 FMEA field in the components profile card.

Finally the RFDM system includes templates for performing FMEA Analysis as shown in figure 5.44

Reliability - Proj-001 System Information:

Profile Card | Links | Notes | Revision | Viewer

**HERMO KING**  
Failure Mode And Effects Analysis

Product/Process: Evaporator Damper System with Meikle-Korff Motor		Process Engineer:		Distribution: FMEA Team
Design Engineer: uncan Lasley, Mike Weiss, reg Truckenbrod		Facilitator: Steve Britton		Date: 8/14/98
Part / Process	Potential Failure Mode	Potential Effects Of Failure	Potential Causes Of Failure	Current Controls
Meikle-Korff Motor Provides rotational motion to gear drive	Fails to rotate open	Door stuck closed - load loss	Moisture Corrosion Lack of grease in gearbox (seal)  Electrical fault Broken leads	Field test Environ Labs testing  Lab testing Supplier testing Sealing test
	Fails to rotate closed	Door stuck open Long defrost time Possible load loss or partial damage Inefficient defrost	Moisture Corrosion Ice  Electrical fault Broken leads	Field test Environ Labs testing  Lab testing Supplier testing Sealing test

Figure 5.45 FMEA template viewer.

## 5.7 Suppliers and Parts Qualification Processes

The final reliability of a product depends heavily in the reliability standards of its components. Providing means for assessing and improving reliability of suppliers and purchased component, has a highly beneficial effect in the reliability figures. The processes of qualifying suppliers and parts are a major support in this area. These processes have the purpose of assuring that the relevant information on suppliers and parts is gathered, and reviewed by all the specified users of the system. When reviewing this information, users must comment, suggest, and finally recommend or not qualification.

### 5.7.1 Supplier Qualification Process

A summary of the steps in the supplier qualification process is given in figure 5.46.

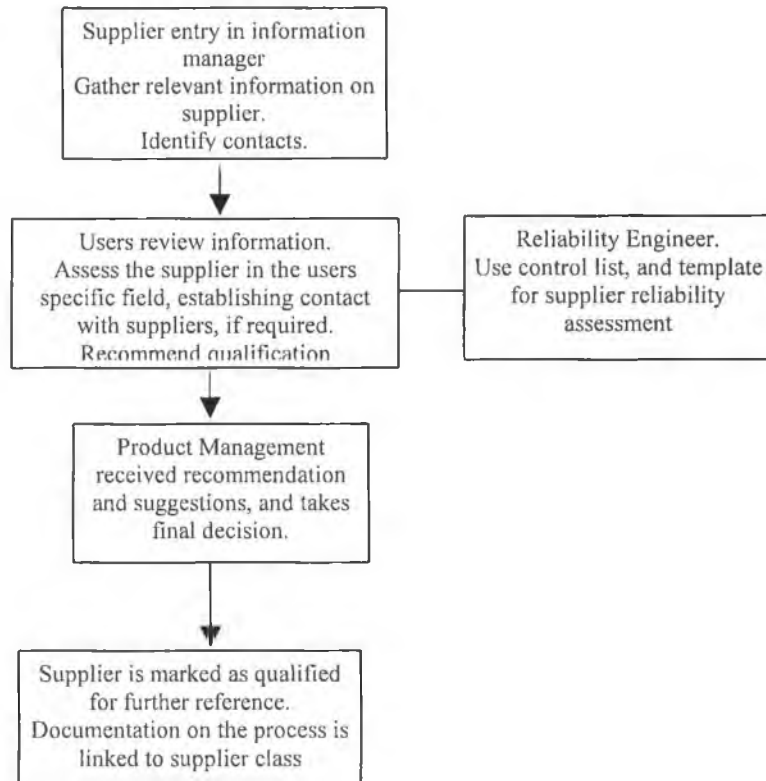

Figure 5.46 Supplier Qualification Process steps.

This process starts by gathering general information on the supplier and establishing contacts for the quality, reliability and design engineers to work with. The information available on suppliers is passed on to the relevant users of the system. Based on guidelines that will be described next, and in personal experience, users will judge different aspects of the supplier operation. In the specific area of reliability, the engineer will consider different issues, review them in collaboration with the allocated contact in the suppliers side and finally recommend or not the qualification of the supplier. Recommended qualifications are then approved by managers, and if positive, a supplier qualification sheet is produced, and the supplier is recorded in the database as qualified. All of the documentation produced throughout this process, e.g. information sheets, brochures or product specifications is linked to the supplier in the database for further reference. The workflow is initiated through the workflow menu as shown in figure 5.47.

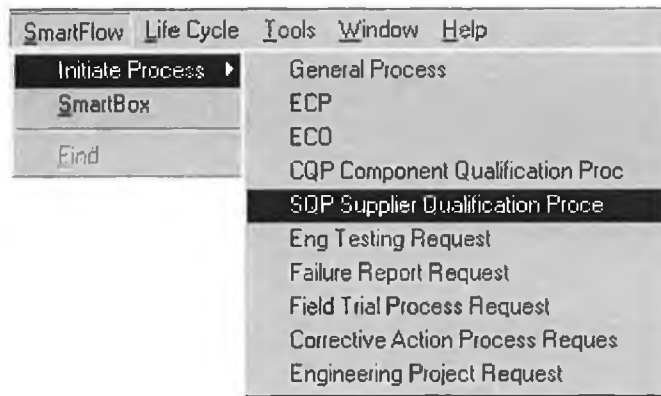

Figure 5.47 Initiation of a Supplier Qualification Process.

The pages of information defined for this process are shown in figure 5.48. All the standard workflow pages such as tasks, history, notes or flowchart are also shown.

 A screenshot of a software window titled 'Supplier Qualification Process'. The window has a title bar with 'Close' and 'H' buttons. Below the title bar is a navigation bar with tabs: 'Profile Card', 'Links', 'Notes', 'Tasks', 'History', and 'Flowchart'. The main content area is titled 'Supplier Qualification Process' and contains the following fields:
 

- SQP Name: Process-000050
- Supplier\_ID: Sup-000001
- Supplier Name: Fabricated Products
- State: New (dropdown)
- End Time: 03/02/2001 1 (dropdown)
- Importance: Normal importance (dropdown)
- Time Limit: 10 00:00:00 (spinner)
- Status: Process is flowing (dropdown)
- Description: Supplier for sheet metal parts. Needed for new evaporator assembly
- Comments: (empty text area)

 There are callout boxes with arrows pointing to specific parts of the form:
 

- 'Process Details' points to the State, End Time, Importance, and Time Limit fields.
- 'Reasons for Qualification' points to the Description field.
- 'The supplier is linked to the process and brought through it' points to the Supplier Name field.
- 'All the information on the workflow can be accessed' points to the navigation tabs.

 At the bottom of the window, there are navigation arrows and a tab labeled 'General/Details'.

Figure 5.48 Supplier Qualification Process.

The flowchart can be viewed. Each node represents a user and each user has tasks to perform. Users perform their tasks, accept the process and pass it on to the next node. This is illustrated in figure 5.49. This figure also shows the task window for the reliability engineer.

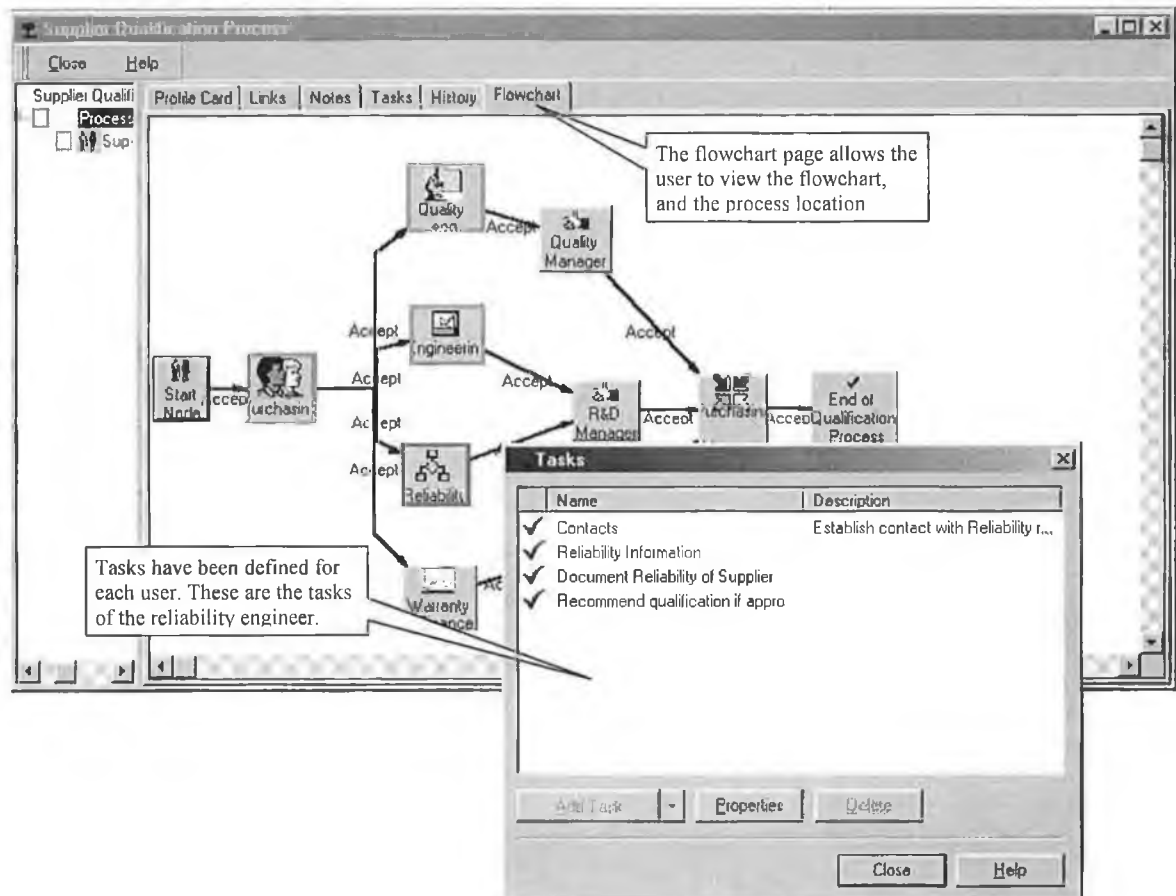

Figure 5.49 Flowchart and tasks in the supplier qualification process.

### 5.7.2 Supplier Reliability Assessment

The reliability engineer uses the checklist and template included in the system to perform a supplier reliability assessment. The information manager stores all the assessments that have been performed, as well as documentation on the supplier operation, and also manuals and guidelines for performing all sort of reliability activities. The reliability engineer has at hand a whole range of information that supports him in the different initiatives and tasks that he/she carries out. Figure 5.50 shows the viewer page of the reliability assessment document that the reliability engineer uses.

Documents - Proj-001 System Information: Profile Card | Links | Notes | Viewer

Title	Supplier Qualification Checklist	Revision
Author	Position	
Date	Location	
Supplier		
Reason for Qualification		
Evaluation Criteria: Understanding Needs		
What is the supplier's process for translating customer needs into quantified technical objectives?		
What is the supplier's process for including reliability techniques, methodology and concepts in the design and manufacturing procedures?		
Does the supplier's equipment or component meet the operating, storage and transportation environmental conditions?		
Does the supplier provide an acceptable warranty program?		
Does the supplier include descriptions or documentation of the physical form of the proposed item for ease of use and/or maintenance?		
Does the supplier's equipment or component include failure indicators, such as fault flags or error messages?		
Is a repair capability available from the supplier?		
Is reliability expertise available during the design and production phases?		
Evaluation Criteria: Approach to Design		
Does the supplier provide sufficient information to indicate that performance based requirements can be met?		
Does the supplier propose trade-off studies for critical design areas?		
Does the supplier's management demonstrate suitable control over subcontractors and vendors?		
What is the supplier's approach for ensuring that the design is sufficiently robust for the intended application?		
Does the manufacturer's design approach provide for adequate design margins?		
Is the manufacturer addressing thermal management in the design?		
What fault tolerance techniques, if any, are included in the design process to reduce system shutdowns?		
Is testability included in the system design?		
Is attention focused on any new or unproven technologies and component, especially those having limited or no record of reliability performance?		
Evaluation Criteria: Approach to Quality		
Does the supplier work with their vendors to improve the quality of their products or services?		

Figure 5.50 Reliability Assessment Template.

Based on this assessment, he/she will recommend qualification. Different users perform different assessments, and finally the overall results are reviewed, and the supplier is qualified or not based on the analysis of each user. This is registered in the suppliers class as shown in figure 5.51.

**Suppliers** 

Supplier ID

Company Name

Qualified Supplier      Date of Qualification  

Figure 5.51 Supplier qualification Information.



### 5.7.3 Component Qualification Process

This process is carried out in a similar way to the supplier's qualification process. The process needs to be initiated when a new component or item is to be incorporated into the design of a product. The Component Qualification Process is carried out when new components are to be used in a product. Figure 5.52 Component Qualification Flow Process

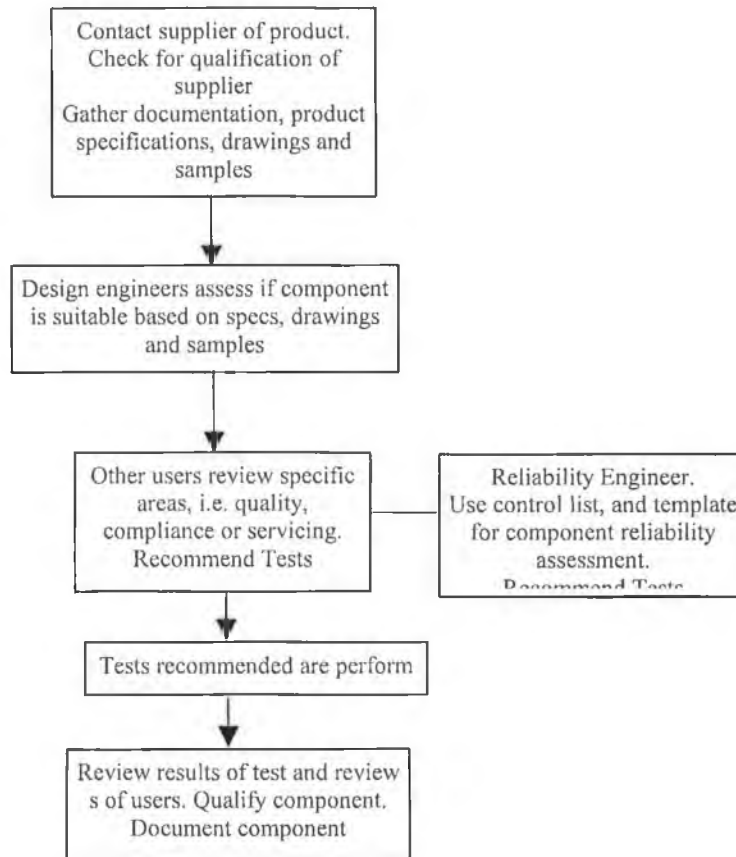

Figure 5.52 Component qualification steps.

At the end of the process a qualified component information sheet will be issued, and the component will be checked in the database as qualified. The process is initiated on the same way as the suppliers qualification process.

### 5.7.4 Checklists for Component Assessment

A number of documents are stored in the information manager that will provide reference and guidelines for qualifying components. The reliability engineer can access a checklist for component qualification, in the reference material class. These checklists are filled in during the qualification process, and make sure multiple issues are considered. A brief summary of findings and discussion on these issues, would usually

be added to the document. Figure shows the component qualification checklist within the system.

Title	Component/Part Qualification Process	Revision
Author		Position
Date	Location	
Supplier		
Reason for Qualification		
Assessment of Product Effectiveness: Relevant Characteristics		
Capability, e.g. capacity, output rate, speed, range, gain, pay-load, information transfer rate, number of channels		
Functional quality, e.g. accuracy, sensitivity, resolution, response time.		
Application factors, e.g. flexibility, versatility, security, mobility, manoeuvrability, connectivity, comfort.		
Ergonomic factors, e.g. reliability, durability, maintainability.		
Aesthetic factors.		
Legal and social factors, e.g. noise, pollution, interference.		
Reliability Evaluation		
Verification that the product requirement concerning operational modes and performance and environmental conditions are within the explicitly stated design specifications of the product		
Verification that the producer and, where relevant, the distributor of the product have an adequate quality assurance system.		
An enquiry about which reliability assurance tasks were performed during design and development, including environmental stress analysis, parts stress analysis, critical parts analysis, FMECA or FMECA, formal design reviews, developmental testing and reliability growth testing. These enquiries should be sufficiently rigorous to give confidence that the tasks were properly carried out. For electronic equipment, information should be obtained about the derating rules that were used in design.		
Enquiry and evaluation concerning product qualification testing. The tests performed, the acceptance criteria and the organization that granted qualification must all be considered in deciding whether the qualification is adequate for the product's intended purpose and environment		
Assurance is required that there is proper discipline for controlling post-qualification design and product changes.		
Enquiry and evaluation as to the reliability screening, e.g. burn-in and environmental stress screening (ESS) performed on the product prior to release for delivery.		
Enquiry as to the production acceptance testing performed prior to release for delivery. Acceptance testing should include some form of reliability testing. The relevance of the testing to the product's intended use and adequacy of the acceptance/rejection criteria must be examined, even if extrapolation to an actual failure rate or reliability figure is not possible.		
Assessment of any quantitative reliability data supplied by the producer, either as part of the product data sheet or documentation or on request. The basis of claimed reliability figures should be checked, including data sources used, tests performed, and assumptions made. The willingness of the producer to supply reliability data for		

Figure 5.53 Component qualification template within the information manager.

## 5.8 Reliability Predictions, Specifications and Requirements

Reliability parameters on parts and assemblies have been divided in three different groups, i.e. reliability predictions, reliability specifications and reliability requirements. Reliability predictions will generally be made for assemblies and products based in the individual parameters of the components, or on empirical models. Reliability specifications will generally refer to reliability parameters from components and parts as supplied by the vendor. Finally reliability requirements, are reliability in design type

of documents, where environmental conditions, modes of failure and reliability parameters for those modes of failure are captured. The relationship between the three types is shown in figure 5.54.

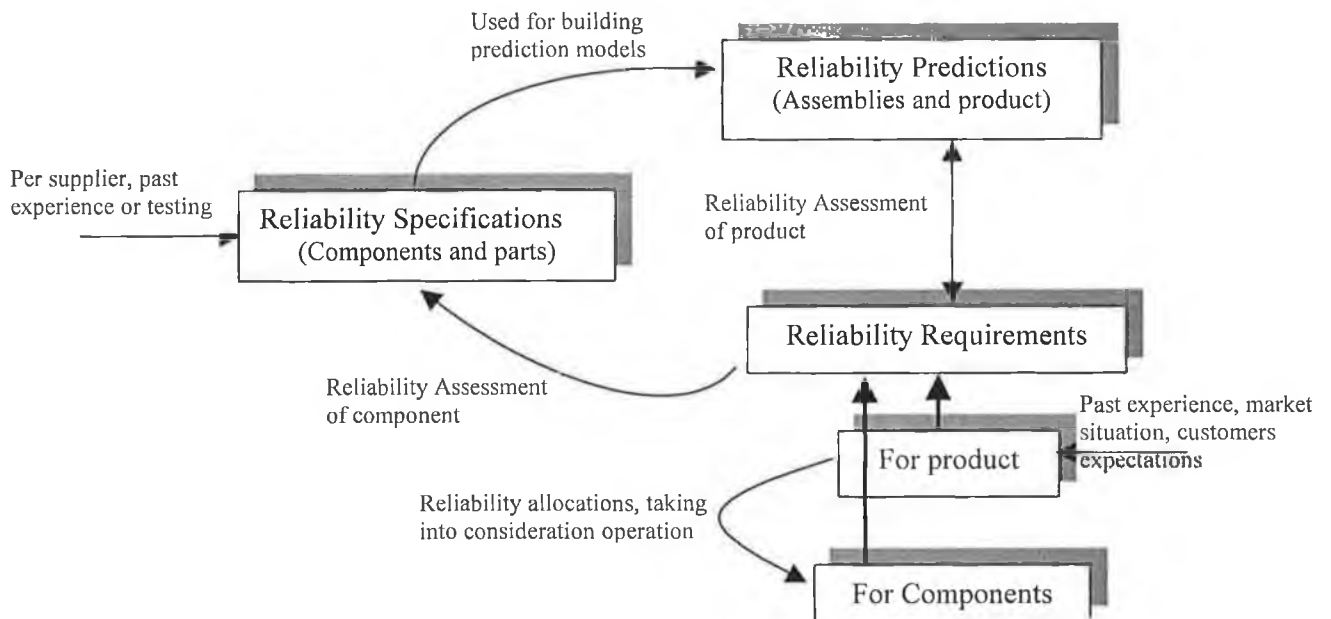

Figure 5.54 Reliability parameters documentation in the system.

### 5.8.1 Reliability Predictions

For generating reliability predictions the reliability engineer will make use of software packages that are integrated within the RFDM system. Reliability Prediction documents coming from the different software packages used are stored in the reliability class. In order to classify them on a useful manner, a prediction type field has been introduced, that determines the kind of analysis and source that produced the reliability prediction. The different types of reliability prediction documents are listed in figure 5.55

Type of Reliability Prediction	1 Test or Field Data
Product Range	Traila
Product Type	
Part Number	4058
Part Name	

Default

- 1 Test or Field Data
- 2 System Reliability Assessment
- 3 Similar Item Data
- 4 Translation
- 5 Empirical
- 6 Physics of Failure
- 7 Software Estimate

Figure 5.55 Reliability Predictions.

The information page for these documents is shown in figure 5.56.

Reliability - Proj-001 System Information

Reliability Tree

- Rel-00010 Reliability Spe
- Rel-00006 Failure Report
- Rel-00005 Top-Cost Nov
- Rel-00008 Reliability Ana
- Rel-00009
- Rel-00002 FMEA on Darr
- Rel-00003 Fault Tree ana
- Rel-00007
- Rel-00001 Description of

Life time distribution summary results

Profile Card | Links | Notes | Revision | Viewer

### Reliability Predictions

Reliability ID: Rel-00008 State: New

Description: Reliability Analysis on Belts

Type of Reliability Prediction: 1 Test or Field Data

Product Range: Trader-Europe

Product Type: [ ]

Part Number: 40582

Part Name: [ ]

Reliability Engineer: Marisa Ocan

Information Analyzed: Failure Data coming from Marshall's Maintenance

Distribution Used: Weibull 3 Parameters

Summary of Results: alpha=0.2, beta=9, gamma=0

Comments: Data might be slightly inconsistent. See report for details

General / Details

Figure 5.56 Reliability Predictions Profile Card.

Reliability predictions are supported with general guidelines and reference. The system includes a range of reference documents on various subjects such as data analysis, life time distributions or physical models.

### 5.8.2 Reliability Specifications

Reliability specifications are stored in the information pages of the component or part, and will generally be added during the component qualification process, by the reliability engineer. Specifications are shown in figure 5.57.

Reliability Information

(per Supplier)

Type of Parameter: [ ]

Reliability figure: [ ]

FMEA Performed

(per Analysis)

Type of Parameter: Percentage of Failures bef

Reliability Figure: 5 before 10000 hours

Date of update: [ ]

5.57 Reliability specifications for a component.

### 5.8.3 Reliability Requirements

Reliability requirements are documents that are added to the system in the reliability class. They include reliability parameters, modes of failure and environmental conditions. A template in the system supports the development of reliability parameters. The information in the profile card and the viewer for a reliability requirement entry are shown in figure 5.58 and 5.59.

**Reliability - Proj-001 System Information:**

Profile Card | Links | Notes | Revision | Viewer

**Reliability Requirements**

Reliability ID: Rel-00010    Phase: [Dropdown]

Revision: [Dropdown]    State: New

Source: Design Analysis

Description: Reliability Specifications and Requirements for Electric Motor

Product Range: Tisdler-Europe

Product Type: [Dropdown]

Part Number: 1040629

Part Name: Electric Motor

Reliability Engineer: Thomas McPhelin

Comments: [Text Area]

General / Details

Figure 5.58 Information page for reliability requirements.

**Reliability - Proj-001 System Information:**

Profile Card | Links | Notes | Revision | Viewer

Title	Author	Date	Location	Position	Revision
Reliability Requirements for Electric Motor	Padraig Heenan	12/2000	R&D gateway		
Purpose: Establish the minimum requirements for reliability of electric motor					

Product Name: S1 300, SL 200, SL 300

Product Number:

Part Name: 1040629

Part Number: Electric Motor

Assembly Name:

Assembly Number:

**Definition of Failure: (more than one definition, please number them)**

- 1 Burned coil
- 2 Snapped shaft
- 3 Damaged Bearing

**Environmental Specifications:**  
(Ref Document on environmental Analysis of electric motor)

**Reliability Requirements:**

Figure 5.59 Template viewed for reliability requirements.

## **5.9 Summary**

This chapter has illustrated the implementation of a prototyped Reliability and Field Data Management System (RFDM). The system consists on different modules. Firstly the information manager, which is based on a PDM solution. Second the field data analysis tools that have been specifically developed for this application. Finally reliability modeling and predictions are done through software tools that are integrated in the system.

Based on the requirements outlined in previous chapters, and the specifications given in chapter four the information structure developed for the RFDM system has been presented. This structure consists of a number of classes and sub-classes that store all the data and information required to operate reliability initiatives. The PDM user interface has been customized, and it provides access control and security, and gives users efficient ways of dealing and retrieving the information.

The chapter has also shown the ways in which the reliability processes described in chapter four are carried out through the RFDM system. These processes include field data analysis, failure report and corrective action system, FMEA analysis, critical item reliability, suppliers and components qualification and finally, reliability predictions and specifications.

For the operation of these processes different features have been added to the system, i.e. templates, guidelines and control checklists. Certain processes that have predetermined workflow paths have been designed into automated processes, so that the system carries out information and documents automatically through the path, and users perform pre-determined tasks sequentially. This has illustrated through a number of processes.

Next chapter will present the conclusions, recommendations and future work that have resulted from the research carried out, and the development of the software system presented in this chapter.

# Chapter 6

## Conclusions and Further Development

### 1.1 Thesis Summary

### 1.2 Results and Conclusions

### 1.3 Further Development

### 1.1 Thesis Summary

The purpose of this thesis was developing an integrated approach to planning, managing and operating reliability within an organization. In order to do this, the author has carried out research in two different areas,

- reliability engineering
- information systems

In the area of reliability engineering, the research has concluded in the need of developing reliability through a process integrated with the life cycle of the product. The author has proposed a model for reliability as a process with three different levels, i.e. management and control, reliability initiatives and operations and finally reliability information flow and feedback.

The first part of the thesis has reviewed the concepts involved in reliability management and operation. Reliability initiatives and methodologies from different stages of the life cycle have been presented. The third level of the reliability process, i.e. information flow and feedback will give structure and ground to the operation of these initiatives. The requirements for such a structure have been outlined, grouped in two different areas. Firstly the information system has to provide analytical and functional features to perform the methodologies reviewed. Second and more important there are a number of requirements for the information structure to be integrated and efficient. Figure 6.1 summarizes these concepts.

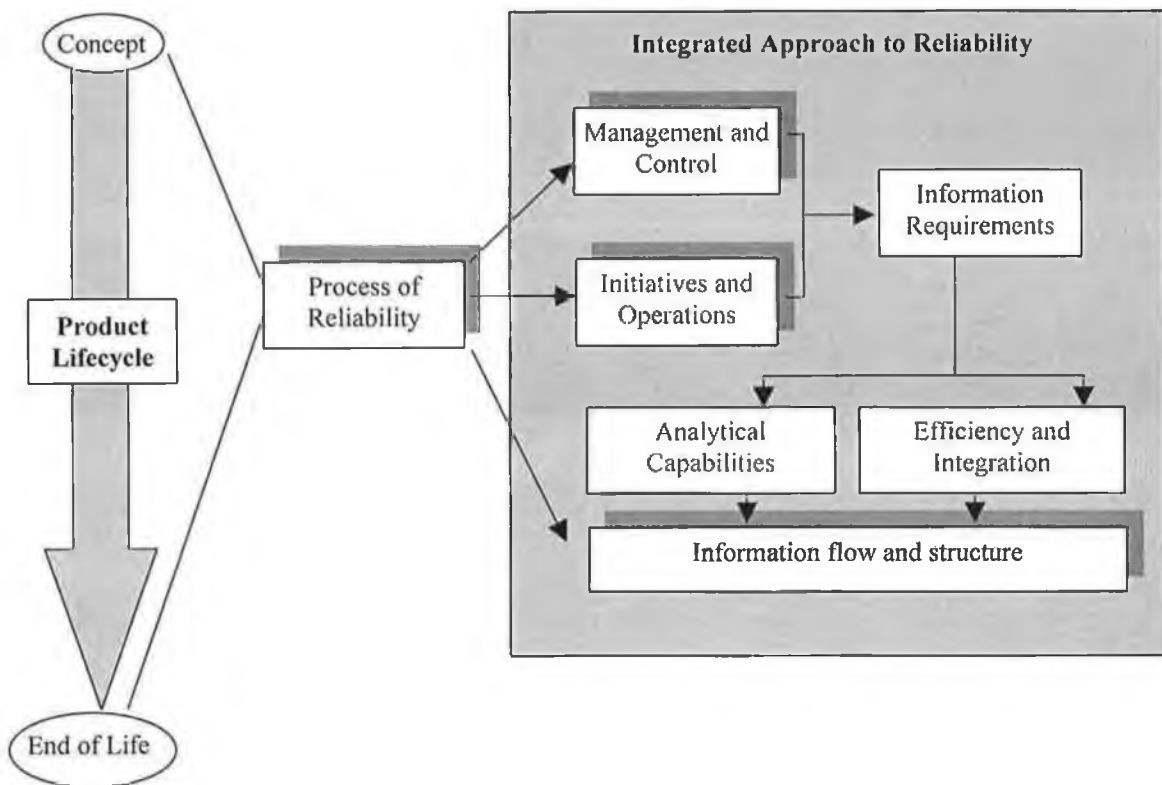

Figure 6.1 Integrated approach to reliability summary.

The research has diverged then into information systems for reliability. A number of reliability software packages have been reviewed and tested against the specified requirements. As a result of this benchmarking exercise, Product Data Management systems (PDM) have been selected as the most suitable tool to develop the framework for reliability operations.

To proof it, a case study has been presented, in which a prototype of a reliability and field data management system had to be developed for a specific application. Chapter four has outlined the structure of this system, its requirements and specifications. Information structure and processes have been described. The prototype has been shown in chapter five. It consists of a software system with different features that include a customized information manager, field data analysis tools, and software tools for reliability predictions that are integrated within the working environment of the reliability engineer. The current chapter will present the conclusions of the thesis and will discuss further developments to the system.



## 6.2 Results and Conclusions

The research and models presented in this thesis have resulted in the development of a system for reliability management and operation. Its operation has been tested by using some of the information and processes of the company that has been used as case study. The system is composed of two subsystems, i.e. the Reliability and Field Data Management system (RFDM) and the Field Data Management system (FDM). The RFDM manages reliability and data within the organization, and operates the information flow and exchange for collaboration. The FDM system provides the tools for the dealers to input and transfer the required information to the company, using web-enabling technology. Both systems interact, and are supported by the same data structure. The RFDM system has been the subject of this thesis, while the FDM system developed within the same project, is described in reference [Her01]. The layout of the system is shown in figure 6.2.

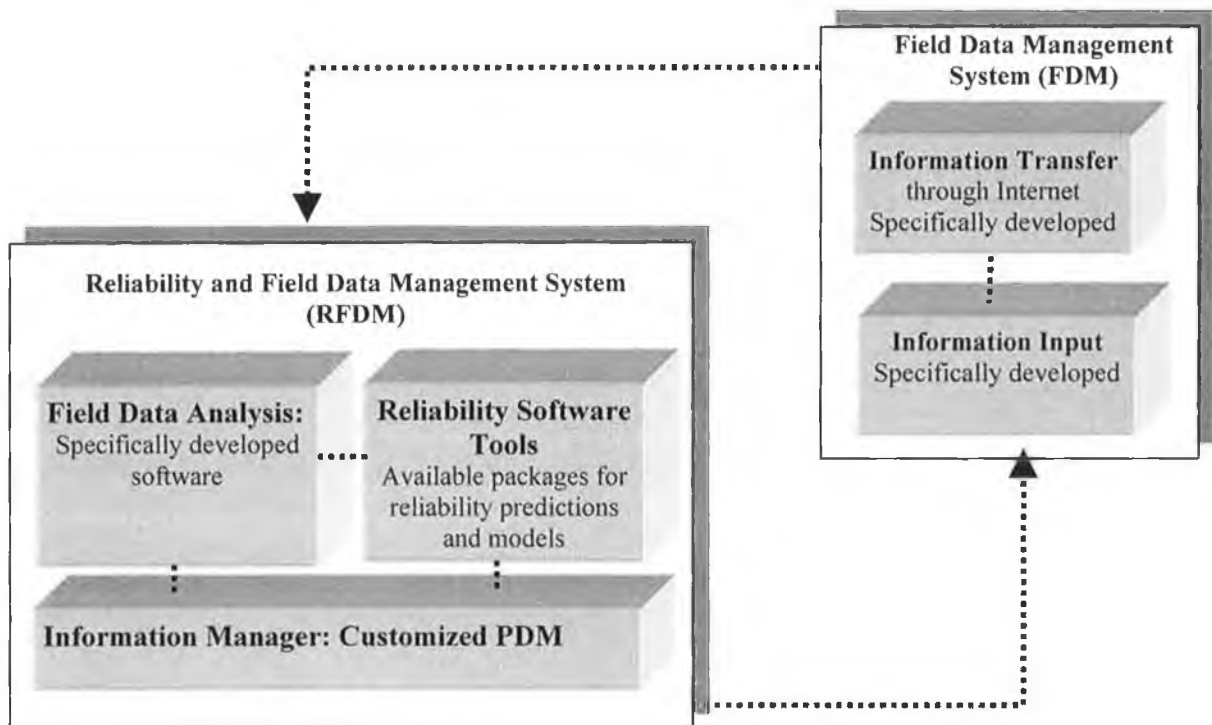

Figure 6.2 Layout of the Reliability and Field Data Management System.

The different tools used by these systems are as follows;

- Information manager. Manages the information structure and reliability processes within the company. It acts as knowledge builder and support collaboration. It also interacts with suppliers and customers for collaboration and feedback
- Field data Retrieval and Transfer tool. This tool developed in the context of the project, which description can be found in reference [Her01], serves two purposes.

Firstly it provides a framework for the dealers to enter the information on a standard format by providing an input tool. Secondly the transfer tool feeds information back into the organization through an internet connection.

- Field Data Analysis tools. These tools are specifically designed to analyze the large amount of data retrieved. Data can be searched, grouped and finally analyzed to give parameters both in reliability and costing.
- Reliability prediction tools. Software packages that are available for the organization are integrated in the RFDM system. These are typically reliability prediction tools.

## Conclusions

Several conclusions have been identified throughout the research carried out in the area of reliability engineering.

- Reliability initiatives and methodologies can be structured in groups that are linked to different phases of the life cycle.
- Reliability of products is affected by different elements at different stages of this life cycle, and as such it has to be approached by a comprehensive structure that deals with the different elements, and integrates them in a common strategy.
- A reliability program needs to be approached by considering reliability as a process, with different inputs and outputs at different levels of the process structure.
- The framework of the operation of the reliability program needs to be an information system that complies with the requirements of the different methodologies and processes that need to be carried out in an efficient and integrated manner,

By researching the area of information systems for reliability, and by testing different software tools developed for reliability work the following issues have been recognized.

- The information system for the reliability program needs to be able to provide analytical capabilities and efficiency and integration features. Analytical capabilities support the reliability methodologies and support the user in performing analysis and calculations in this context. Efficiency and integration refers to the need of the system to integrate the different methodologies in a single structure. It also involves providing features that facilitate information sharing within the company, involvement of suppliers and customers in the reliability effort, and finally, incorporate into the system the latest information technology developments such as web-enabling capabilities, integration with other organizational information system, or automation of information and work flows. Knowledge building and management must also be supported.

- At present, most of the software tools that support reliability work are orientated towards analytical issues. They provide the means for performing a number of methodologies, such as reliability predictions and simulations or fault tree and FMEA analysis. However, in general, the approach is not integrated, and they are mostly tools focused on certain areas, rather than supporting the overall program. They do not provide customization tools, or the possibility of further developments.
- Product Data Management systems are very complete tools for supporting engineers in their activities. These systems manage data and processes, and provide user-friendly environments where information can be accessed and retrieved in an efficient way. They also include features like access control, security, revision systems for documents or web enabling capabilities that are very suitable for building a ground structure to support engineering operations. Most of the PDM systems are fully customizable and offer integrations with CAD packages, enterprise resource planners, and other well-used software tools.
- In the specific area of reliability, PDM systems have the great advantage of offering information management across the entire product life cycle, and the possibility of integrating suppliers and customers into the structure. For all of these reasons PDM systems have been selected to develop the reliability management system.

All throughout the research process, the author interacted with ThermoKing Europe that is the industrial partner in the Reliability and Field Data Management for Multi-component Products (REFIDAM) Project. This interaction and collaboration resulted in the development of a prototype system based on the operation of reliability engineering for this company. Because of the requirements of the company, a number of reliability initiatives were selected, and specific attention was placed on the need of providing the means for retrieving and analyzing field data. These data would be available for the company from their dealer network that operates and manages the units in their operational life. The benefits of having access to this data was recognized, from a reliability engineering perspective, since it would give engineers access to a very valuable source of information, i.e. the best testing scenario for reliability parameters, that are real life environmental, maintenance and operating conditions.

The benefits of operating this system are as follows;

- The reliability effort is consistent, monitored and participated to the rest of the organization through information sharing, and using the capabilities of the information manager system. Knowledge is build through the documentation added to the system, so that it can serve as reference for further work.

- The system also achieves integration of dealers, by opening certain information to them in the form of web access. This assures a dynamic and flexible link, with dealers being able to retrieve the latest updates on product support and maintenance.
- Retrieval and analysis of field data has proven to be highly beneficial for assessing reliability parameters, for determining and ranking poor reliability performance of parts and for establishing cost of ownership models, which can help in developing maintenance methodologies and marketing strategies.
- The system developed through PDM has the added advantage of having excellent customization tools, which allow for flexibility and support the organization in adapting to changing trends, processes and products.

All throughout the development of the prototype, its functionality was tested against the companies operations and processes. As a result of this, constant changes were introduced, to improve the output. Despite of this a series of issues is still recognized, both in the operation of the system and the concepts behind the model.

- The information management system needs to be managed. Any software, especially in the area of information management, is as good as the quality and accuracy of the information that it stores. Because of this reason, special attention is given in the system to provide user-friendly environments and ease of use features. The system must be seen by the engineers as an efficient support in their activity rather than an extra-load in their daily tasks. This will be possible by providing an efficient system but also by providing appropriate training and information on the operation of the system, and creating a favorable atmosphere around it.
- In the specific area of field data management, great effort must be put in developing standard data structures, without which consistent analysis is very difficult to carry out. The field data analysis will depend greatly in the level of acceptance of the input and transfer information system from the dealers side. Training dealers in the importance of feeding the right information, and convincing them that this process will result in their own benefit is an important issue. To do this, focus must be placed in the feedback flow of information structure and also in developing an input tool that facilitates management of their own operations, through automatic unit registration, invoicing system, automatic order of spare parts, and general management of their workshops.
- Finally because of the approach to reliability as a life cycle activity integrated in every aspect of the organization structure, the RFDM system should be integrated within the organizational information structure. It should be able to communicate with the ERP

systems, and any other system that are in place. This task is usually supported by the PDM applications.

### 6.3 Future Developments

The RFDM system has a great scope of future developments. A number of issues have been recognized throughout the research carried out, and are listed below;

- Integration with organizational information systems, in order to operate the system with the same data structure and data source as the other operational systems within the organization.
- Integration of the system with suppliers information systems as to provide immediate and automatic data exchange and translation. This is one of the concepts that is being developed and researched in the area of PDM systems. In the future modules will be added, that will operate between the organization and its suppliers translating information and data between the systems.
- The software tools that are used within the RFDM system could be developed so that automatic data exchange is carried out. An example of this could be results from reliability prediction software being automatically added to certain fields in the PDM structure, or results from FMEA analysis being immediately updated to the failure modes manager.
- Throughout the research carried out, certain areas were looked at that would improve greatly the support phase collaboration. Utilization of WAP technologies in accessing the information structure would allow for maintenance and troubleshooting being supported by mobile phones connections. This would be a great advantage to support these operations in the field, when units are not in the workshops. Another beneficial functionality would be the utilization of e-tag systems. These systems used microchip technology to store data on products or components. The chip is attached to the unit and component. Technician or engineers can automatically download this data by connecting their laptop to the chip through a special connecting probe. The information stored in the chip can include serial number, maintenance operations carried out or failure history of the component or unit. Integrating this tool to the field data support would be also valuable for maintenance and support operation and for management of failure and data history of products.

Figure 6.3 shows how these integrations would be structured.

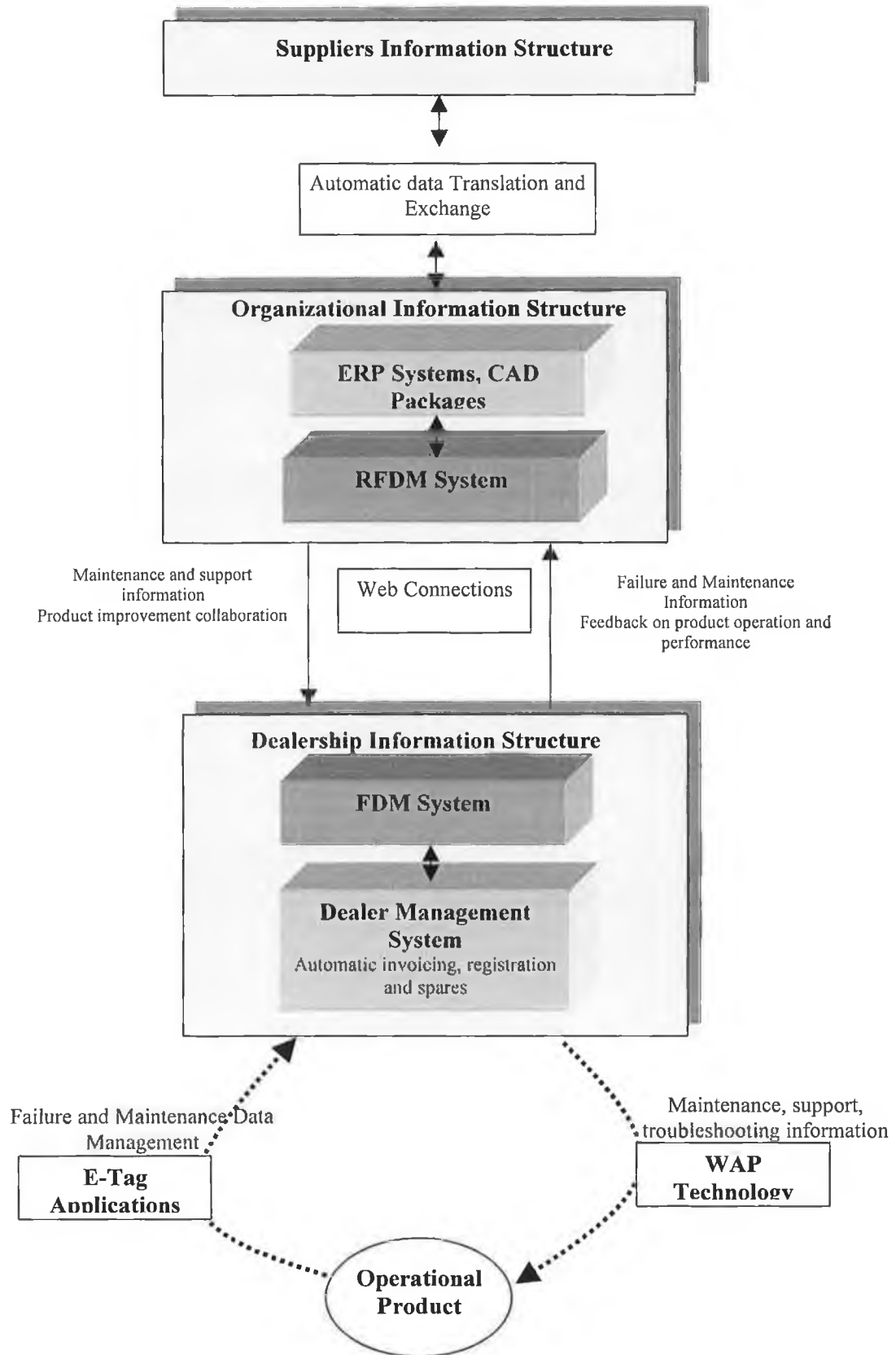

Figure 6.3 Further developments for the RFDM System.

## References

- [ABS00] <http://www.abs-jbfa.com/reliability.html>, ABS group Inc.
- [Ari00] <http://www.arinc.com>, ARINC.
- [Baj83] H. J. Bajarria, "Integration of Reliability, Maintainability and Quality Parameters in Design", Society of Automotive Engineers, 1983.
- [Bla92] Henry S. Blanks, Reliability in Procurement and Use, John Wiley & Sons, 1992.
- [Bou00] Richard W. Bourke, "Product Data Management: More than just an ERP Module", CPIM, 2000.
- [Bow99] Bowles, "Failure Modes Effects and Criticality Analysis, Reliability and Maintainability Symposium", Tutorial Notes, 1999.
- [BQR00] <http://www.bqr.com>, BQR Reliability Engineering LTD.
- [Car97] A.D.S. Carter, Mechanical Reliability and Design, MacMillan Press Ltd, 1997.
- [Dav94] John Davidson, The Reliability of Mechanical Systems, Mechanical Engineering Publications limited, 1994.
- [Dre00] <http://www.dreamscape.com/aac/software.html>, Dreamscape.
- [Dun80] D.G. Dunnoon, "Design for Reliability", Proceedings of the Annual Reliability and maintainability Symposium, 1980.
- [Eng00] <http://www.engineerdsoftware.com/rma.asp>, Engineerdsoftware.
- [Eva99] Evans, "Practical Reliability Engineering & Management", Reliability and Maintainability Symposium, Tutorial Notes, 1999.
- [Frac00] <http://www.fractalsoln.com/>, Fractal Solutions.
- [Gra96] W.Grant Ireson, Clyde F. Coombs, Richard Y. Moss, Handbook of Reliability Engineering and Management, McGraw-Hill, 1996.
- [Her00] Padraig Heron, "Design and Functional Specification of a Field Data Management System", REFIDAM Project, Galway-Mayo Institute of Technology, 2000
- [HP99] Hewlett Packard, "Understanding Product Data Management", Hewlett Packard.
- [Iso00] <http://www.isograph.com>, Isograph Direct.
- [Ite00] <http://www.itemuk.mcmail.com>, Item Software.
- [Item98] Isograph Products, Item Software Documentation: AvSim+, FaultTree+ and RCMCost, Isograph products, 1998.
- [Kap77] K.C.Kapur, L.R.Lamberson, Reliability in Engineering Design, John Wiley & Sons, 1977.
- [Kec91] Dimitri Kececioglu, Reliability Engineering Handbook, Prentice Hall, 1991.

- [Lau00] Kenneth C. Laudon, Jane P. Laudon, Management Information Systems, Organization and Technology in the Networked Enterprise, Prentice Hall, 2000.
- [Man00] T.H. Mandemaker, Dr. H. J. Peis, "RapidPDM: Faster Implementation of PDM, Rapid PDM": Faster Implementation of PDM, 2000.
- [Mor93] A. Morris, Swenguin Whang, "Competing in product and service: a product life cycle", Managemet Science, 1993.
- [Oco91] Patrick D.T. O'Connor, Practical Reliability Engineering, Third Edition, John Wiley & Sons, 1991.
- [RAC00] <http://rac.iitri.org>, Reliability Analysis Center.
- [Ray00] <http://www.raytheon.com>, Raytheon.
- [Rel97] Reliasoft Corporation, Life Data Analysis Reference, Reliasoft Publishing, 1997.
- [Relex00] <http://www.relexsoftware.com/>, Relex Software Corporation.
- [Relia00] <http://www.reliasoft.com> Reliasoft Corporation.
- [Roc99] Thomas Roche, "Development of a software tool to improve ownership life cycle costs of multi component products", Application Proposal, 1997
- [rst00] <http://www.rstcorp.com/services/reliability.html> , Reliability Software Technologies.
- [Sam00] <http://samicorp.com/strategicplanning.htm>, Samicorp.
- [Sar97] Philip Sargent, "Product Data Management (PDM) and Manufacturing Resource Planning (MRP)", PDM Information Center, 1997.
- [Sar97] Philip Sargent, "The Product Data Management (PDM) and Related Software Markets", PDM Information Center, 1997.
- [Sma00] Smart Solutions, SmarTeam Documentation: Administrator, user and smartflow guides, Smart Solutions, 2000.
- [SoH00] <http://www.sohar.com/meadep>, SoHaR Incorporated.
- [SST00] <http://users.erols.com/sstc>, SSTC Support systems.
- [Sta97] D.H. Stamatis, Failure Mode and Effect Analysis, McGraw Hill, 1995.
- [Tha86] S.B. Thayer, Tutorial on Reliability, ASQC Quality Congress Transaction, 1986.
- [Tsa93] Shou-kuo Scott Tsao, "An Overview of Product Information Management", Pan Pacific Conference on Information Systems, 1993.



# Bibliography

## Reliability Engineering

- "Integrated Reliability analysis system (IRAS)", G. Kocza, A. Bossche, Quality and Reliability Engineering International, 1996.
- "Customer Driven Reliability: Integration of QFD and Robust Design", Kai Yang, K. Kapur Proceedings of the Annual Reliability and Maintainability Symposium, 1997.
- "Reliability Engineering based procedural approach for product development", Parreen.S, Goel, Naua Singh, Industrial Engineering Research conference Proceedings 1997.
- "Field Data is Reliability Information: Implementing and Automated Data Acquisition and analysis system", James Jauw, Pantelis Vassiliou, Proceedings Annual Reliability and Maintainability Symposium, 2000.
- "Warranty and Reliability", Blischke, Proceedings Annual Reliability and Maintainability Symposium, 2000.
- "Process Failure Analysis by Block Diagrams and Fault Trees" Industrial & engineering chemicals fundamentals, 1976.
- "Quantitative FMEA automation", T. Montgomery, K. Marko, Proceedings of the Annual Reliability and maintainability Symposium, 1997.
- "Design Review Escapes: how to avoid them", Brian Burdiak, 1995.
- "Reliability In Design", L.J. Phaller, J.P. Brach, Westinghouse Electric Corporation, 1997.
- "Quality in Design", William A. Ganter, Quality and Reliability Engineering International vol. 4, 1988.
- "Combining Reliability tools and Simultaneous Engineering, Automotive Engineering International, Aug 1988.
- "Reliability Assurance in Commercial Product Design" K. W. loegering, Quality Progress, Aug 1973.
- Selection and Use of Engineering Materials, J.A.Charles, F.A.A. Crane Butterworths. 1980.
- "A General Statistical Model for Random Fatigue", P.H. Wirsching, E. B. Haugen, Journal of engineering Materials and Technology, 1974.
- "Strategy of Selecting a Burn-In Plan", John C. Smith Rockwell-Collins, 1978.
- "Tutorial on Reliability", S.B. Thayer, ASQC Quality Congress Transaction, 1986.
- "Three Steps to Improve Product Reliability", S.B. Thayer, ASQC Quality Congress Transaction, 1986.

- "The Arrhenius, Eyring, Inverse Power Law and Combination Models in Accelerated Life Testing" Dimitri Kececioglu, Julie A. Jacks, Reliability Engineering, 1984.
- "Application of combined environments reliability tests: Results of the DOD Cert Workshop", John F. Wagner, State of the Art Techniques in Reliability Engineering 11, 1985.
- "Summary of HALT and HASS results at an accelerated", Reliability Center Mike Silverman Proceeding of the Technical Program, NEPCON 1997.
- "Robust Design By variability optimisation", Parkinson, D.B. Quality and Reliability Engineering International 1997.
- "Prototype for Integrated Hazard Analysis", Dong-Hsiung Kuo, Ding-Shang Hsu, AIChE journal 1997.
- "Use of a hazard and operability study for evaluation of ABS", Michael Schneider, SAE special Publications, 1997.
- "Compressor Reliability-a multiple Responsibility", Various Authors, American Society of Heating, Refrigerating and Air-Conditioning Engineers, 1972.
- Quality and Reliability Engineering International, volume 14, number 5. Various, John Wiley & Sons 1998.
- "Reliability Program Planning in a Commercial Environment", Hough, Reliability and Maintainability Symposium, Tutorial Notes 1999.
- "Understanding Weibull Analysis", Salzman, Reliability and Maintainability Symposium, Tutorial Notes 1999.
- "Reliability Centered Maintenance", Zwingelstein, Reliability and Maintainability Symposium, Tutorial Notes 1999.
- "Reliability in today's business environment" Dana Crowe Reliability and Maintainability Symposium, Proceedings, 2000.
- "A 'Reliability Development Program' for the Swedish industry", Sven Vikman, Reliability and Maintainability Symposium, Tutorial Notes 2000.
- "Using benchmarking to introduce & improve reliability engineering", Marl L. Morelli, Reliability and Maintainability Symposium, Tutorial Notes 2000.
- "Reliability Prediction", Healy, Reliability and Maintainability Symposium, Tutorial Notes 1999.

### **Product Life Cycle**

- Product Design and Development, Karl T. Ulrich, Steven D. Eppinger, McGraw Hill, 2000.
- "Reasons for Considering Automation Economic Life Cycle Analysis", Peter G. Martin Productivity Enhancement, conference proceedings 1997.
- "What's the Key? Tool Approaches for determining key characteristics", D. Somerton, S. Mmlinar, Annual Quality Congress transactions, 1996.

## **Information Systems and Information Management**

- Managing Information Strategically, James McGee, Laurence Prusak, Ernst & Young, 1993.
- Managing Customer Value, Bradley T. Gale, The Free Press 1994.
- The Arthur Young Practical Guide to Information Engineering, Arthur Young Information Technology Group, John Wiley & Sons, 1987.
- Business Process Oriented Implementation of Standard Software, Mathias Kirchmer, Springer, 1999.

## **Product Data Management Systems**

- "Successful Implementation of Product Data Management Systems", Bruce Friers Premier Design Systems, Inc, 1995.
- "How The Technology has Evolved", Hewlett-Packard, Hewlett-Packards, 2000.
- "New PDM Apps Are More Capable at Managing Complex Data Relationships", PDM Information Center, Cmstat, 2000.
- "New Directions in the Aerospace and Defence Industry: Integration of PDM and ERP Systems", Richard W. Bourke, CPIM, 2000.
- "Product Information Management: A Key Building block-Product Life Cycle Definition", Richard W. Bourke, CPIM, 2000.
- "PDM: The Essential Technology for Concurrent Engineering", Bill Gascoigne, 2000.
- "Why PDM Projects Go Astray?", Machine Design, 1996.
- "Ten Steps to Ensuring a Successful PDM Project", Michael Rudy, Document Management, 1995.
- "Engineering Automation Report", Steven Weisberg, EAReport, 1998.
- "What is Product Data Management and Why Should I care?", Christopher S. Williams, The Sun Observer, 1994.
- "PDM versus Imaging. Look Before You Leap", Brion Caroll, ImagingWorld, 1998.
- "Terms of Data Management", Mark Silvestri, Life Cycle Solutions, 1998.
- "Before the PDM Project Starts: What Should You Know", Engineering Department Management & Administration Report, 1996.
- "Best Practices Provide 'Voice of Experience' Advice for PDM", Engineering Department Management & Administration Report, 1996.
- "Lessons From Experts: Tips for Smoother Installation of PDM", Engineering Department Management & Administration Report, 1995.
- "Taking the Hype out of Selecting Your best PDM Vendor", Engineering Department Management & Administration Report, 1995.
- "Get Ready for a cPDM Shakeout", Ed Miller, CIMdata, 2000.

- "Extending cPDM to Field Support", Ed Miller, CIMdata, 2000.
- "PDM Trends and Challenges", Ed Miller, Machine Design 1997.
- "PDM and the Internet", Alan Mendel, Mechanical Engineering Magazine, 1999.
- "PDM E-Business Takes Off", Ed Miller, Computer-Aided Engineering Magazine, 1999.
- "Focused Solutions Bring PDM to the Mainstream", Ed Miller, Computer-Aided Engineering Magazine, 1999.
- "Agile Anywhere: a Standards-Based Solution for the E-Supply Chain", Agile Software Corporation, 1999.
- "PTC: Where are they now", Charles Clark, CadCam Magazine, 2000.
- "SmartVault A Technical White Paper", SmartSolutions, SmartSolutions, 2000.
- "Choosing a PDM Solution", SmartSolutions, SmartSolutions, 2000.
- "Workflow a Tehnical White Paper", SmartSolutions, SmartSolutions, 2000.
- "Integrating the Enterprise using the PDM Schema and the PDM Enablers", Bror Salmelin, Proceedings Product Data Technology (PDT), 2000.
- "A 'Learning by Doing' Approach for Making Mechanical Engineering a Repeatable and Auditable Process", Dick Laan, Proceedings Product Data Technology (PDT) 2000.
- "Engineering Work Flow-The Process in Product Data Technology", Jacques Spee, Proceedings Product Data Technology (PDT) 2000.
- "Collaborative Management of the Product Definition Lifecycle for the 21st Century", Jordi Portella, Proceedings Product Data Technology (PDT) 2000.
- "How to use PDM and Configuration Management in "Product Development and Life Cycle Management" Martijn Toelofs, Proceedings Product Data Technology (PDT) 2000.
- "Product Data in Small and Medium Sized Companies", Oyvind Horntvedt, Johannes Storvik Proceedings Product Data Technology (PDT) 2000.

### **Databases and Programming**

- Visual Basic 6 Database Programming, John Connell, WROX, 2000.
- VisualBasic 6, Peter Wright's, WROX, 2000.
- Programming in SQL, John Carter, McGraw Hill, 2000.
- Database Systems, Design, Implementation and Management, Peter Rob, Carlos Coronel, Boyd & Fraser publishing company, 1995.

### **Web-Pages**

- Reliability Analysis Center (RAC), <http://rac.iitri.org>
- EEVL-Reliability Analysis Center, <http://www2.ee vl.ac.uk/show/lib3corlejr.829818192>
- PDM Information Center, <http://www.pdmic.com>
- Johny Stark Information, <http://www.johnystark.com>

- CIM Data, <http://www.cimdata.com>
- ACCEL Technologies, Inc [http://www.acceltech.com/PDM\\_Home.html](http://www.acceltech.com/PDM_Home.html)
- Agile Software Corp, <http://www.agilesoft.com>
- Auto-trol Centra 2000, <http://www.auto-trol.com>
- Ceimis Enterprises, <http://www.ceimis.com/>
- Cmstat Corporation, <http://www.cmstat.com/>
- CONCENTRA, <http://www.415.com/demos/consensys>
- SmarTeam Solutions, <http://www.smartsolutions.com>
- E-Tag Applications, <http://www.oxleygroup.com>

## Appendix 1: Statistical Distributions used in Reliability

## The Exponential Distribution

One of the most commonly used distributions, due to its simplicity is the *Exponential Distribution*. The *pdf* of the exponential distribution is mathematically defined as

$$f(t) = \lambda e^{-\lambda t}$$

In this expression,  $t$  refers to the random variable, which represents time and the Greek letter lambda  $\lambda$ , represents what is commonly referred to as the parameter of the distribution. Depending on the value of  $\lambda$ ,  $f(t)$  will take on different shapes. The simplicity of the function relies on the fact that the exponential distribution has a constant failure rate that is actually the parameter  $\lambda$ . The Mean Time to Failure for the exponential distribution is the inverse of this failure rate, i.e.  $\frac{1}{\lambda}$ . Under this assumption, given an item has lasted two years, the chances of failing in the next day is the same as an item, which has lasted 10 years [Hea99]. The form of the exponential density function is illustrated in the next figure.

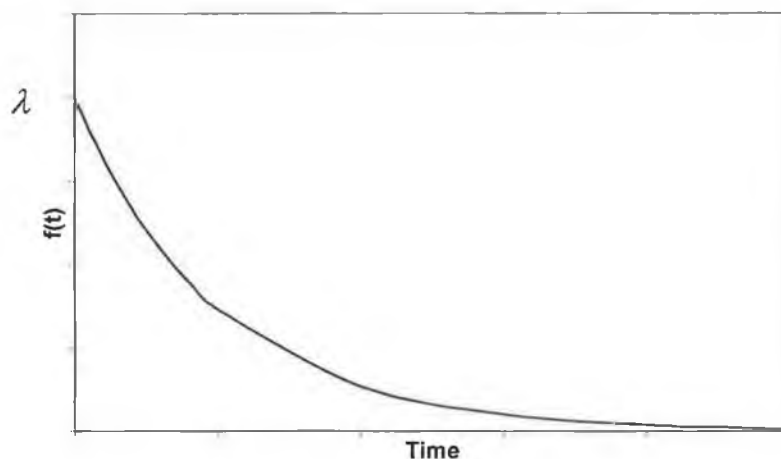

Most mechanical components do not show this constant failure rate behavior, however there are certain conditions under which the exponential distribution can be used. Most mechanical or electromechanical products sold for consumer use consist of series system from a reliability standpoint. This means that all components must function for the system to function. Therefore, the system has a number of different failure modes. It has been proven by research and testing that when this is the case, the failure distribution of the global system, that result of the combination of the various failure distributions at the component level, follows an exponential model. This is the situation where the exponential distribution finds its major application, and the reasons for it being very commonly used.

There is a whole statistical theory on the exponential distribution, and there are several methodologies that can be used to make a correct analysis of data with this *pdf*. Although further details on this can be found in the references of the thesis, here are some of the concepts related to this distribution that can be very practical in reliability work.

#### **Data Analysis. Barlett's test**

Data should be analyzed carefully both from an engineering and a statistical standpoint. Sometimes results that prove insignificant from a statistical standpoint may still provide insight from an engineering standpoint. There are some basic statistical tests that can be conducted to assess the validity of using the exponential distribution as a failure model.

The basic test is termed Bartlett's test, and the test statistic is given by the following formula [Kkap77].

$$B_r = \frac{2r \left[ \ln \left( \frac{t_r}{r} \right) - \frac{1}{r} \left( \sum_{i=1}^r \ln x_i \right) \right]}{1 + (r+1)/6r}$$

where  $x_i$  is the random variable representing time to failure,  $r$ , is the number of failures and

$t_r = \sum_{i=1}^r x_i$ . Under the hypothesis of an exponential distribution, the statistic  $B_r$  is *chi-square*<sup>1</sup> distributed with  $r-1$  degrees of freedom, and a two-tailed *chi-square test* is in

order. After the necessary calculations the hypothesis can be rejected or not, depending on the chi-square distribution values. Some examples of applications of this test can be found in the references of this thesis.

#### **Testing for Abnormally Short Failure Times**

In product testing, short failure times can be caused by such things as manufacturing defects or substandard material. Such defects result in components that are not representative of the population as a whole, and thus the failure can be eliminated from further analysis. Although the best way to judge whether or not a particular failure is representative, is an engineering analysis, there are some statistical tests that can be applied, to support one's intuition when the engineering analysis is not possible. The mathematical expression of this test is given in the next formula;

$$F_{1-\alpha, 2, 2r-2} > \frac{(r-1)x_1}{\sum_{i=2}^r x_i}$$

---

<sup>1</sup> The Chi-square distribution is an statistical distribution, often used in hypothesis testing. Given a variable and a degree of freedom, the value of the chi-square distribution can be looked at in reference tables, and compare with an experimental value, in order to accept/reject a hypothesis.



The assumption is that  $x_1$  is the short failure time. If the failure time is significantly small, this inequality will be truth. For easier statistical calculations the formula below is recommended. Further description of the application and mathematical concepts behind the formula can be found in the references.

$$F_{\alpha, 2r-2, 2} < \frac{\sum_{i=2}^r x_i}{(r-1)x_1}$$

### Testing for Abnormally Long Failure Times

The same type of reasoning as used in the previous test can be applied to determine if a failure time is abnormally long. Redeveloping the previous test procedure,  $x_1$  represents an abnormally long failure time if

$$F_{0.05, 2, 2r-2} < \frac{(r-1)x_1}{\sum_{i=2}^r x_i}$$

where  $x_j$  could be any failure time, not necessarily the first failure time.

### The Normal Distribution

The Normal or Gaussian distribution is the most widely known distribution. A population that conforms to the normal distribution has variations, which are symmetrically disposed about the mean. An important reason for the wide applicability of the normal distribution is the fact that, when a value is subject to many additive sources of variation, irrespective of how these variations are distributed, the resulting composite distribution can be shown to approach the normal distribution. This is known as the central limit theorem [PO'Con92]. It justifies the use of the normal distribution in many applications, including engineering, particularly quality control. The normal distribution is a close fit to most QC and some reliability observations, such as the sizes of machines parts and the lives of items subject to wear out failures, as well as to natural phenomena such as the heights of adults and strengths of materials.

The *pdf* of the normal distribution is given by the expression shown next;

$$f(t) = \frac{1}{\sqrt{2\pi}} \exp\left(-\frac{(t-\mu)^2}{2\sigma^2}\right)$$

Where  $t$ , represents the normal times to failure,  $\mu$  the mean times to failure and sigma, the standard deviation of the times to failure. The integral form, i.e.  $F(t)$  cannot be evaluated in a closed form, and there are tables for the standard normal density function available that can be used to find probabilities for any normal distribution.

The reliability function for some normal random variables is shown in the next figure.

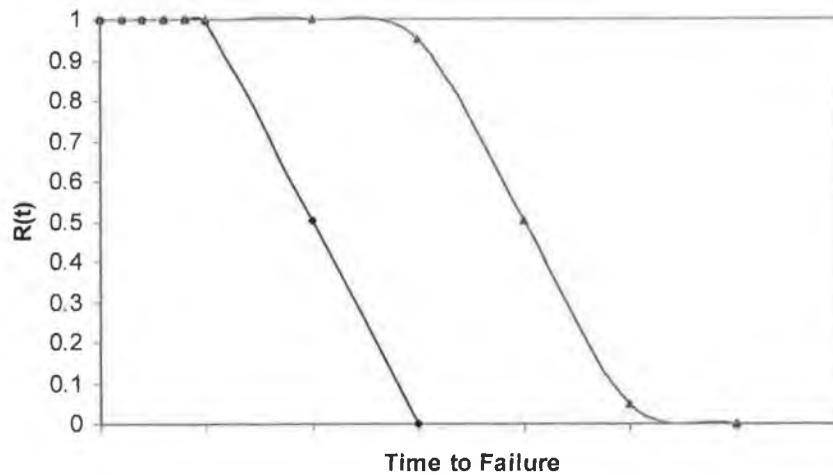

Some examples of application are incandescent lamps, mechanical components at high alternating stress levels in the neighborhood of the proportional limit, or failure stress of many structural materials.

### The Lognormal Distribution

A random variable is lognormally distributed if the logarithm of the random variable is normally distributed. The lognormal distribution is commonly used for general reliability analysis, cycles to failure in fatigue, material strengths and loading variables in probabilistic design [Relia99].

The *pdf* of the lognormal distribution is given by the following expression;

$$f(t) = \frac{1}{\sigma\sqrt{2\pi}} \exp\left[-\frac{1}{2}\left(\frac{\ln t - \mu}{\sigma}\right)^2\right]$$

Some example of the applications of the lognormal distribution can be found in the analysis of non-linear crack growth rate, life data of bearing and the lives of some transistors.

### Weibull Distribution

Weibull analysis is a powerful statistical technique for obtaining information about the failure distribution and life associated with a particular component failure mode. It is a very flexible tool for determining the underlying statistical distribution that best represents the failure history of a part. Weibull analysis is widely used throughout industry to determine the fatigue and yield strength of metals, in addition to the reliability and life of mechanical components, such as seals, pumps, rolling element bearing and turbine blades [Sal99].

The Weibull distribution was conceived by Professor Waloddi Weibull to describe the variability of the mechanical properties of materials. It is an optional two or three

parameter distribution that is highly versatile and can approximate many other statistical distributions.

The Weibull distribution has several features, which make it attractive to practicing reliability engineers, and which account for its very wide use [Dav99];

- Flexibility. It can deal with increasing, constant and reducing hazard rates.
- Mathematical simplicity
- Amenability to graphical analysis.
- Demonstrated ability to fit most lifetime data better than most of its potential competitors.

In its three parameter form the Weibull model is most simply described by its cumulative distribution function, i.e.  $F(t)$ , that is shown in the equation below;

$$F(t) = 1 - \exp\left[-\left(\frac{t - \delta}{\eta - \delta}\right)^\beta\right]$$

The parameters of the Weibull distribution, are full of meaning.  $\eta$  is the scale parameter, known as the characteristic life. It is the value of  $t$  at which there is an approximately 2/3 probability that the component will have failed. Strictly the probability is 0.632.  $\beta$  is a shape parameter which is related to the behaviour of the hazard rate function.

- For  $\beta = 1$ , the hazard rate is constant, that is equivalent to the exponential function.
- For  $\beta > 1$ , the hazard rate increases, and the larger  $\beta$  is, the more rapidly it is increasing. However it is unusual to have values greater than 4.
- For  $\beta < 1$ , the hazard rate is reducing. The smaller  $\beta$  is, the more rapidly it reduces.  $\beta$  must be greater than zero, and it is unusual to encounter values lower than 0.5.

The two parameters, specify which particular member of the family of functions or curves will describe the data. Component reliability analysis based on the Weibull model reduces to a process of estimation of these parameters.  $\delta$ , is the representation for this third parameter, and it represents the failure free life of the components.

### **Weibull Analysis**

In its original form, the Weibull distribution was based on three parameters. The three parameters analysis can also be done in the same way as the two parameter analysis.

This is the process of obtaining estimates for the parameters, from observed failure data. There are both analytical and graphical methods available. There are also various commercial software packages available that perform Weibull analysis quickly and easily.

The process of analyzing data for Weibull analysis has the following steps:

- **Input Data Preparation.** Different types of failure data may be curve-fit using Weibull distributions. When the individual failure times are known and all items in a test have failed, this is defined as complete data. If a given test set contains both failures and non-failed items, which are referred to as suspensions, and the times are known, this is termed mixed data. Grouped failure data exist when the failure times are not known precisely and occur in specific intervals of time. Grouped data with failures and suspensions are termed grouped mixed data. Free-form data occur if the individual failure times and cumulative probabilities are known [RSa199].
- **Ordering Data.** When the data is mixed before proceeding to the following step, the data must be ranked. Ranked order numbers must be calculated to account for suspensions in the data after it has been sorted. This is done with an iterative formula using Johnson's<sup>2</sup> method.
- **Finding Median Rank Values.** When the cumulative failure probabilities for the data are not known, median rank values are normally used because of small plotting error. Median ranks are 50<sup>th</sup> percentile plotting positions for the data that may be determined for complete or mixed data. If the failure data are grouped, failure probabilities are approximated from the cumulative relative frequencies of histograms at the cell mid-points and the data are treated as free-form.
- **Curve-Fitting Weibull Distributions.** Once the estimates for the cumulative probability are calculated through the steps above, the values are represented after logarithmic transformations in a special kind of graph, or graph paper. This paper includes the necessary transformations for converting the cumulative distribution a straight line. After the points are represented in this paper, different line-fitting methods can be used i.e. least square methods, regression in x or regression in y.

The graph layout allows, once the line is fitted to calculate in a very straightforward manner the parameters of the distribution. With the three parameters determined all the other reliability functions can be now represented.

The Weibull analysis is based on a series of algorithm and estimates that can sometimes be difficult to deal with, especially when large amount of data is analysed. However, as it has been mentioned before, there are several software packages available that allow the analyst to easily fit a Weibull distribution into a set of data. It is very convenient to use these packages, because of their simplicity and speed of calculations. Despite of this, a general

---

<sup>2</sup> Further information of this method can be found in references of the thesis [Sa199], [Kpa77].

understanding of the procedure in Weibull analysis, on the assumptions made and the concept involved is necessary in order to be critical with the results, and to interpret fully the outputs from the analysis.

### **Gamma Distribution**

The failure density function for a gamma distribution is given by

$$f(t) = \frac{\lambda^\eta}{\Gamma(\eta)} t^{\eta-1} e^{-\lambda t}$$

where  $\eta$  is the shape parameter and  $\lambda$  is the scale parameter. The cumulative frequency distribution, is given by;

$$F(t) = \sum_{k=\eta}^{\infty} \frac{(\lambda t)^k \exp[-\lambda t]}{k!}$$

The gamma failure density function has shapes that are very similar to the Weibull distribution and can also be used to model the time  $n_{th}$  failure of a system if the underlying failure distribution is exponential.

## Appendix 2: Probabilistic Engineering Design Methodology

## **Probabilistic Design Methodology**

The first step in the probabilistic design methodology is to perform environmental computations, which affect the stress and strength of the component under analysis. For the strength computations, consideration must be given to the properties of the material used and the probability distributions of factors affecting the strength, such as surface finish and surface treatment. For the stress computations, the load statistics history and the probability distributions of factors affecting stress, such as stress concentration and temperature, must be considered. Based on these computations, the stress and strength distributions and their statistics can be obtained. The steps in the process are as follows [Car97]:

1. Establishment of a preliminary design
2. Estimation of external forces.
3. Analysis of the preliminary system, including force intensity in components expressed as probability density functions.
4. material selection based on mechanical and physical properties and economic feasibility
5. Description of strength and failure characteristic of the material, including its probability density function.
6. Quantitative estimates of strength and failure characteristics of components. There are functions of
  - a. Engineering
  - b. Geometric considerations
  - c. Anticipated operational loads
7. Description of collective strength and failure characteristics.

If we consider the total design reliability program, the steps will be as summarized below [Kap77]:

1. Define the design problem
2. Identify the design variables and parameters involved
3. Conduct a “failure modes, effect and criticality analysis
4. Verify the significant design parameter selection
5. Formulae the relationship between the critical parameters and the failure governing criteria involved
6. Determine the failure governing stress function
7. Determine the failure governing stress distribution
8. Determine the failure governing strength function
9. Determine the failure governing strength distributions

10. Calculate the reliability associated with these failure governing distributions for each critical failure mode
11. Iterate the design to obtain the design reliability goal
12. Optimize the design in terms of performance, cost, weight, etc.
13. Repeat optimization for each critical component
14. Calculate system reliability
15. Iterate to optimize system reliability

### Strength and Stress Distributions

It is relatively easy to find references for the statistical aspects of strength. Some of the most common used distributions in this area, that have proven to be valid, are given in the table below. It is somehow more difficult to find theoretical modes for loading, or stress conditions, since these depend greatly on every specific situation, are they are not standardized. Although some references are also given in the table below, this is something that will depend on the designer's team experience, and knowledge.

<i>Topic</i>	<i>Distribution</i>
<b><i>Strength Distribution</i></b>	
Strength of materials when assumption is that the stress of the component is determined by the weakest point	Extreme Value Distribution
Strength of materials when assumption is that the distribution of strength is related to mean values	Normal Distribution
Ultimate tensile, yield and endurance strengths of steels	Normal Distribution
Strength properties of structural alloy materials	Log-Normal Distribution
Strength of ferrous materials, different heat treatments, surface conditions	Weibull distribution with different parameters
In some cases, the probability distribution of time to failure at a given stress level is sometimes found to be left-skewed	Log Normal or Gamma Distribution
<b><i>Stress Distribution (more difficult, more relying in experience)</i></b>	
Rocket Motor Thrust	Normal Distribution
Gas pressure in cylinder heads of reciprocating engines	Normal Distribution
Various conditions	Various Dist

### Safety Factors and Reliability

As shown in figure 1, the statistical distribution can be characterised by a mean and a standard deviation. If an event occurs in which there is an overlap between both distributions, failure is likely to occur.



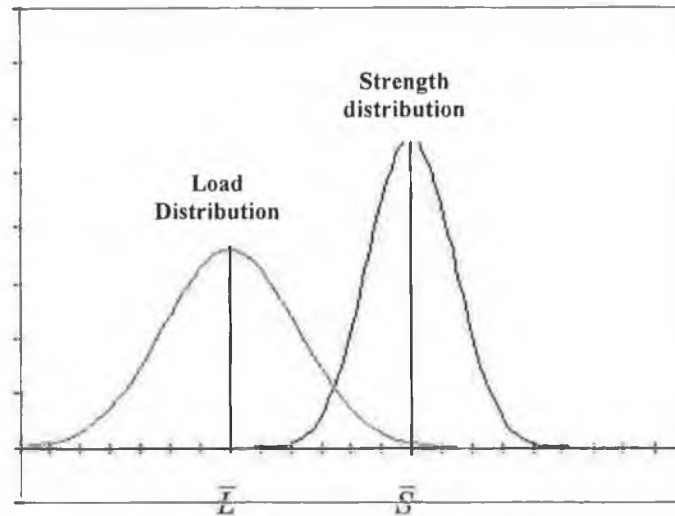

An example of this would be a steel shaft subjected to stress. The properties of the material vary depending on the presence of defects, cracks, or welding areas. The stress applied on the shaft, can vary with different tensions on belts, different speeds of rotation or simply different locations for the welding position of the supporting bracket. If an extremely weak shaft is subjected to a very high load, the shaft can fail, even if the design safety factor seemed to be appropriate.

In order to make a more comprehensive analysis of the real situation, two safety factors may be defined, i.e. the *safety margin* and the *loading roughness*, as shown in the following equations. The *safety margin* is the relative separation of the mean values of load and strength, and the *loading roughness* is the standard deviation of the load, both relative to the combined standard deviation of the load and strength distributions [ACar97].

$$SM = \frac{\bar{S} - \bar{L}}{\sqrt{(\sigma_S^2 + \sigma_L^2)}} \quad \text{Eq. 2.1}$$

$$LR = \frac{\sigma_L}{\sqrt{(\sigma_S^2 + \sigma_L^2)}} \quad \text{Eq. 2.2}$$

These parameters allow us to analyse the way in which load and strength distribution interfere, so that a more accurate measure of probability of failure can be provided. In these conditions, the random variable  $y = s - l$ , is related to the reliability of the component by

$$R = P(y \geq 0)$$

When strength and stress random variables have normal density functions,  $y$  is normally distributed and the reliability  $R$  is given by the following equation;

$$R = \frac{1}{\sqrt{2\pi}} \int_{-\infty}^{\infty} -SM \exp^{-z^2/2} dz$$

where  $z$  is the standard normal random variable and  $SM$  is the safety margin.

An example of results in applying this method is given in the next table.

Case no	Mean Strength	Mean Stress	Strength Standard Deviation	Stress Standard Deviation	Conventional safety factor	Reliability
1	50	20	2	2.5	2.5	1.0
2	50	20	8	3	2.5	0.9997
3	50	20	10	3	2.5	0.9979
4	50	20	8	7.5	2.5	0.9965
5	50	20	12	6	2.5	0.987
6	25	10	2	2.5	2.5	0.9999994
7	25	10	1	2.5	2.5	0.9999999999999996
8	50	10	20	5.0	5.0	0.9738
9	50	40	2	1.25	1.25	0.99909
10	50	10	5	5.0	5.0	1.0

The next graphs show the interference of the stress and strength distributions for case number 1, number 2 and number 8, and how this relates to the value of reliability for that given interference.

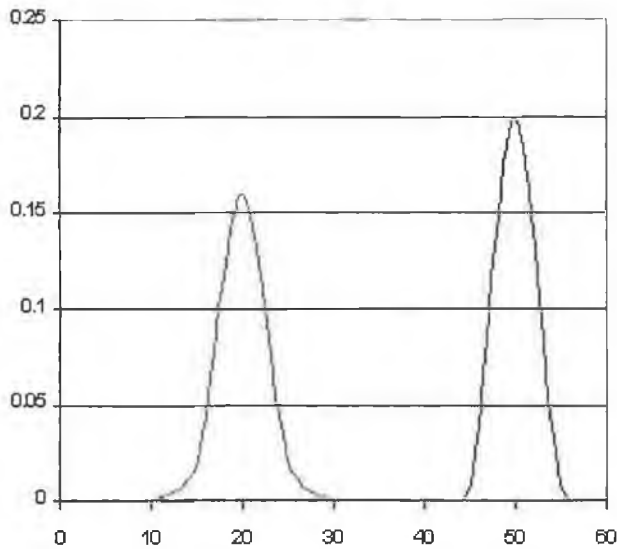

**Case 1**  
**Reliability:1.0**

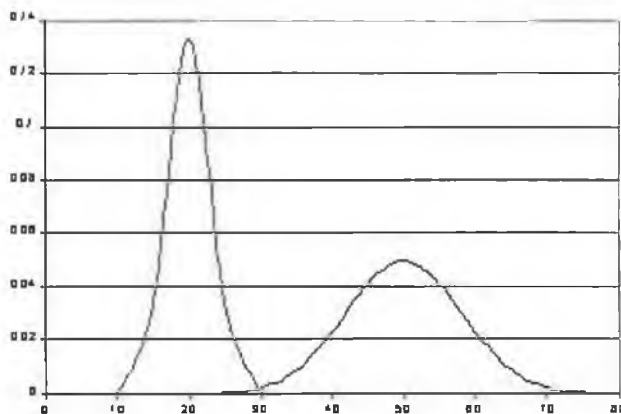

**Case 2**  
**Reliability:0.999**

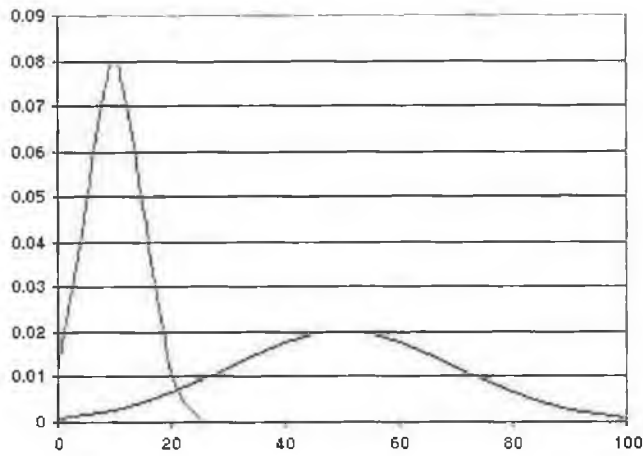

**Case 8**  
**Reliability:0.9738**

As in any other statistical analysis, this result can be given with a certain confidence level. Statistical formulas have been developed to perform this analysis to various different distributions of stress and strength. There is a methodology for assessing distribution of a designed component, as the combination of the effect of the random variables in design. There are reliability formulas and tabulated values for different stress-strength interference models, both static, and dynamic<sup>3</sup>. More information on this area can be found in the references of the thesis, [Kkpa77]. [Acar97]. In summary, probabilistic design is a realistic way to develop a quantitative and statistical estimate of the performance of a design before it leaves the drawing board. The main disadvantage of this approach is that it requires a good knowledge of probability and statistics, and not every design engineer has this knowledge. The probabilistic approach forces the designer to quantify uncertainty in the design variables and thus understand the inherent reliability of the design. Because this approach statistically quantifies design performance, it will help the designer to assess warranty costs, establish maintenance programs and schedule inventories [Kap77].

---

<sup>3</sup> A dynamic model takes into consideration the change of reliability levels with time. Time dependant models are more difficult to develop and evaluate than static models.

## Appendix 3: Reliability Allocation Methods

## Equal Apportionment Technique

The equal apportionment technique assigns equal reliabilities to all the subsystems in order to achieve a specified level or reliability for the total system. The system is assumed to consist of  $n$  subsystems in series. The main drawback of this method is that the subsystem reliability goals are not assigned in accordance with the degree of difficulty associated with meeting them. The equation governing this model is as follows;

$$R_i = (R_s)^{1/n}, i = 1, 2, \dots, n.$$

## The ARINC Apportionment Technique

In the ARINC method we assume that the subsystems are in series with constant failure rates, that any subsystem failure causes a system failure, and that the subsystem mission times equal the system mission time. The apportionment technique requires the expression of the required reliability in terms of the failure rates. The steps from this techniques are summarized next.

1. Determine the subsystem failure rates ( $\lambda_i$ ) from the past data, observed or estimated.
2. Assign a weighting factor ( $\omega_i$ ) to each subsystem according to the failure rates determined in step 1, where ( $\omega_i$ ) is given by

$$\omega_i = \frac{\lambda_i}{\sum_{i=1}^n \lambda_i} \quad i = 1, \dots, n$$

3. Compute the subsystem failure rate requirements using

$$\lambda_i = \omega_i \lambda \quad i = 1, 2, \dots, n$$

Therefore this method allocates the new failure rate based on relative weighting factors that are functions of the past failure rates of the subsystem.

## The AGREE Allocation Method

The AGREE allocation method is more sophisticated than the previous methods. This method is based on component or subsystem complexity and explicitly considers the relationship between component and system failure. The AGREE formula is used to determine the minimum MTBF for each component required to meet the system reliability. It is usually applied in electronic equipment, and is based on assessing the complexity of a component based on the number of modules and circuitry of the component. The allocation

assumes that each module makes an equal contribution to the system success, i.e. each module has the same failure rate. The allocated failure rate of the  $i_{th}$  unit is given by,

$$\lambda_i = \frac{N_i [-\ln R_s(t)]}{N \omega_i t_i}$$

where

$t$  is the mission time, or the required system operation time

$t_i$  is the time units for which the  $i_{th}$  subsystem will be required to operate during  $t$  units of system operation

$N_i$  is the number of modules in the  $i_{th}$  subsystem

$N$  is the total number of modules in the system

$w_i$  is the importance factor for the  $i_{th}$  subsystem

$R_s(t)$  is the required system reliability for operation time  $t$ .

## Appendix 4: Reliability Prediction Methodology

## Series Systems

The series configuration is probably the most commonly encountered model and, fortunately, is also the simplest to analyze. In a series system all subsystems must operate successfully if the system is to function. The block diagram model of a series system is given in the next figure;

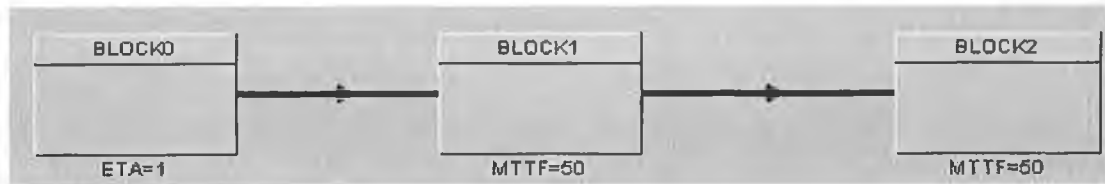

If we assume these events are independent then we have that the reliability of the system is given by the following equation;

$$R_s = \prod_{i=1}^n R_i$$

where the right hand side indicates the product of the subsystem reliabilities.

This equation constitutes what is commonly called the product rule in reliability. If one wants to meet a given system reliability a rapid approximation for the necessary level of subsystem reliability is obtained using the formula that follows;

$$R_x \approx 1 - nq$$

where  $q$  is the probability that the subsystem will fail.

## Parallel Systems

A parallel system is a system that is not considered to have failed unless all components have failed. The reliability block diagram for a parallel system is given in the next figure;

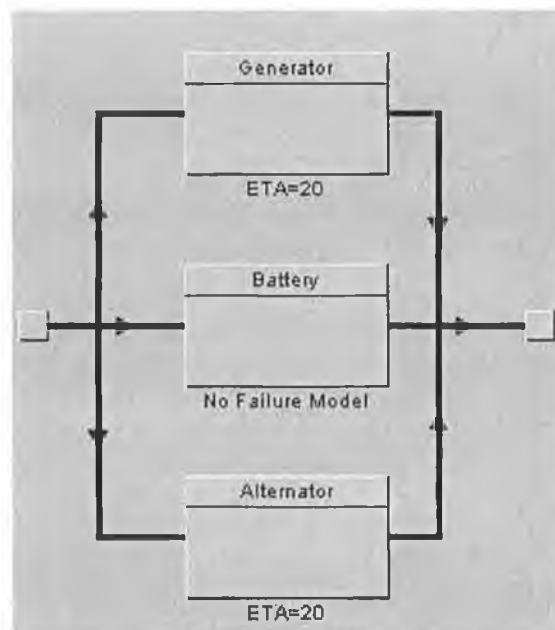



The system reliability is given by the following equation:

$$R_s = 1 - \prod_{i=1}^n (1 - R_i)$$

In analyzing a parallel system in this fashion it is implied that all subsystems are activated when the system is activated and that failure do not influence the reliability of the surviving subsystems. The parallel arrangement shown in the last figure is considered a pure parallel situation, and is usually not representative of many parallel arrangements. In reality the standby<sup>4</sup> redundant and share parallel<sup>5</sup> arrangement are more often used, particularly in mechanical systems [Kap77].

#### *Series-Parallel Design Considerations*

Simple combinations of parallel and series subsystems are easily analyzed by successively collapsing subsystems into equivalent parallel or series components. An example would be the arrangement shown below;

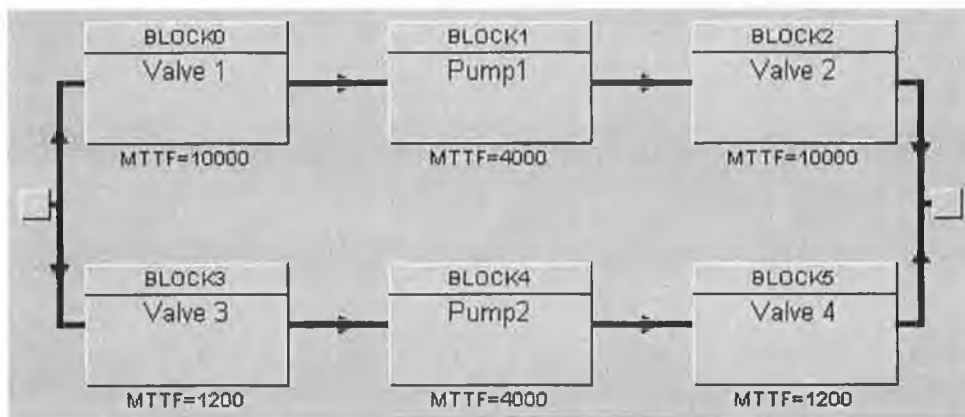

Certain design configurations or complex failure modes may produce systems in which pure parallel or series configurations are not appropriate. The procedure to follow then, although not simple, is generic to all possible situations. It consists on examining all possible mutually exclusive modes of the system, and then since these modes are mutually exclusive, the probabilities can be summed. The obvious disadvantage of this method is that the number of failure modes increases rapidly with the number of components. This number of failure modes can be calculated with the following formula;

$$\sum_{x=0}^n \binom{n}{x}$$

<sup>4</sup> In the standby redundant system, the standby component is not activated unless the on-line component fails.

<sup>5</sup> In the share parallel system, the failure rate of surviving components increases as failure occur.

## Reliability Considerations in Design

The design process dictates the system configuration and the configuration chosen influences the reliability level, as well as the cost of achieving this level. Thus, a preliminary reliability analysis as well, as the many other design factors should be considered during design phase. Some of the commonly used reliability trade-offs are given next.

The reliability of a series system can be improved by decreasing the number of series components, or increasing the component reliabilities. The next graph shows the effect of increasing component reliability;

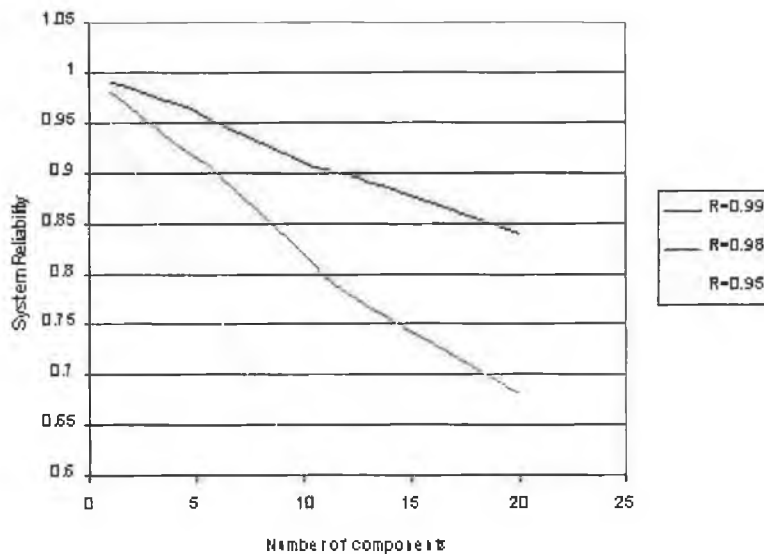

The graph shows the effects of increasing component reliability; however, the marginal gain in system reliability becomes smaller as component reliabilities increase. The deterioration of system reliability that results from increasing the number of components is also evident.

The paralleling of components is usually mentioned as a means to improve the system reliability. However, the gains are not always realizable. First of all, designing a parallel system for a mechanical device is usually extremely difficult. Some forms of parallel arrangement such as providing spare parts (a standby parallel arrangement) or using a load-sharing design are probably more representative of the true situation. The second problem with parallel arrangements is that for a given component reliability, the marginal gain due to the addition of parallel elements slows down rapidly. Thus the marginal gain in reliability by paralleling may not be as profitable as considering and improved component. This is shown in the next graph

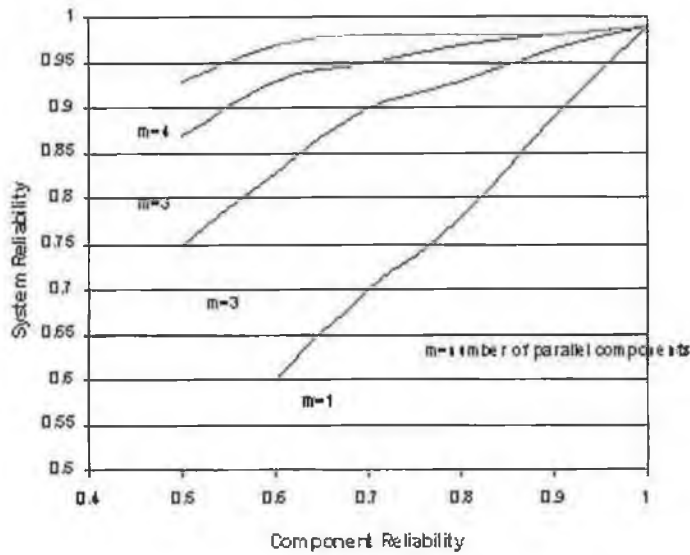

Finally, if we have  $n$  components, and we can either provide redundant branches at component level or at system level, statistics show that the low-level redundancy gives a higher system reliability in all cases. However, the difference is not as pronounced if components have high reliabilities.

Appendix 5: PDM Customisation: Sample of Information  
Pages

# Projects Class

- Project General Information

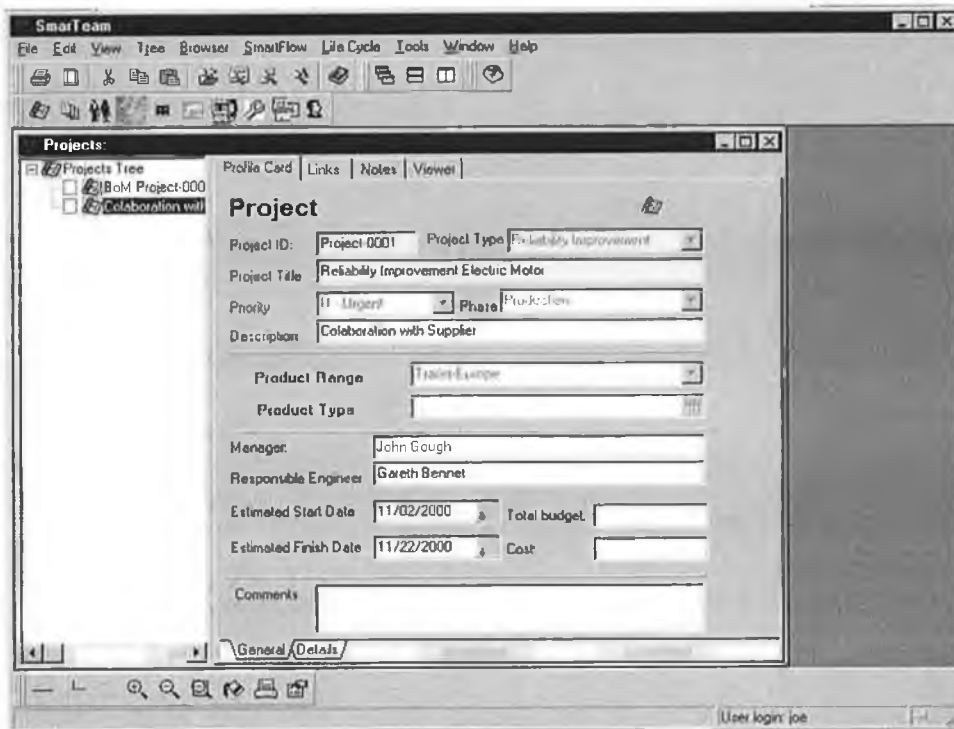

- Project Details

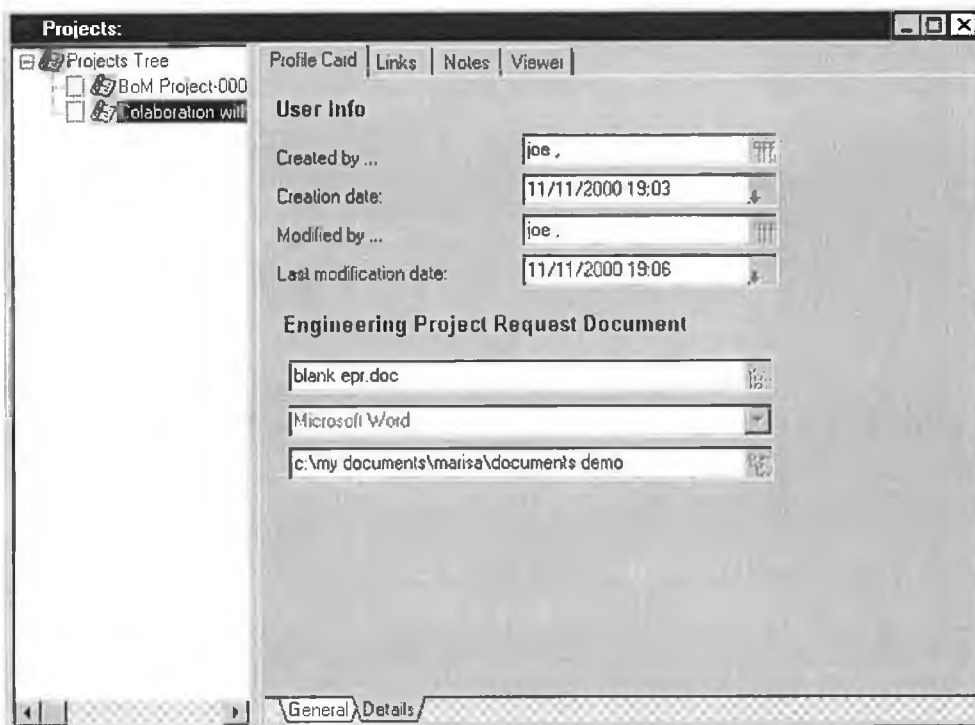

- Project request viewer

**ENGINEERING PROJECT REQUEST (EPR)**

ORIGINATOR \_\_\_\_\_ LOG NO \_\_\_\_\_

**PROJECT CATEGORIES**

1. Customer order.      3. Strategic Platform    5. Field Problems  
 2. Strategic Breakthrough    4. Cost Reductions    6. General Development.    7. Reliability Improvement.

ENGINEERING PROJECT REQUEST. (EPR) (be as specific as possible and list any applicable documents)

\_\_\_\_\_

\_\_\_\_\_

## Suppliers Class

- Suppliers general information

**Suppliers - Proj-001 System Information**

Suppliers Tree

- Sup-000008 Danloss
- Sup-000007 Aiba Asociados
- Sup-000006 BOSCH
- Sup-000005 Leroy Somer
- Sup-000004 Montes y Asociados**
- Sup-000003 AWP
- Sup-000002 Caragh Tool & Die
- Sup-000001 Caulfield Electronic

**Suppliers**

Supplier ID: Sup-000004  
 Company Name: Montes y Asociados  
 Qualified Supplier      Date of Qualification: 05/04/2000

Description: Electrical and Electronic Parts

Address: Teabel la Católica  
 City: Zaragoza  
 State: \_\_\_\_\_  
 Country: Spain

Phone: \_\_\_\_\_  
 Phone: \_\_\_\_\_  
 Fax Number: \_\_\_\_\_  
 Web Page: \_\_\_\_\_  
 Email Address: \_\_\_\_\_

Supplier's General Info / Contacts / Details /

- Supplier Contacts

**Suppliers - Proj-001 System Information:**

Suppliers Tree

- Sup-00000
- Sup-00000
- Sup-00000
- Sup-00000
- Sup-00000
- Sup-00000
- Sup-00000
- Sup-00000

Profile Card | Links | Notes

**Engineering Contact**

Position

Phone

Mobile

email

**Sales Marketing Contact**

Position

Phone

Mobile

email

**Reliability Contact**

Position

Phone

Mobile

email

Supplier's General Info | Contacts | Details

## Products Class

- Product general information

**Products - Proj-001 System Information:**

Products Tree

- SL 200 30
- Assbly-000002
- Assbly-000001
- SL 300 50
- Assbly-000003
- SL 500
- SL 200 50
- SL 100

Profile Card | Links | Notes | Revision

**Product**

Product ID  Phase

Revision  State

BoM Number

Service Part Number

Product Name

Model Code

Product Range

Manufacturing Plant

Comments

Product General | Specifications | Details

- Product specifications

**Products - Proj-001 System Information:**

Products Tree

- SL 200 30
  - Assbly-000002
    - Comp-0001
      - Part-000002
      - Part-000001
  - Assbly-000001
    - Comp-0002
- SL 300 50
  - Assbly-000003
- SL 500
- SL 200 50
- SL 100

Profile Card | Links | Notes | Revision

**Performance Parameters**

	Diesel	Electric
0	<input type="text"/>	0 <input type="text"/>
-20	<input type="text"/>	-20 <input type="text"/>
Speed	<input type="text"/>	

**Components**

Engine

Compressor

Controller

**Reliability Specifications**

Reliability Parameter

Reliability Figure

FMEA Reformed

Product General | Specifications | Details

- Product Details

**Products - Proj-001 System Information:**

Products Tree

- SL 200 30
  - Assbly-000002
    - Comp-0001
      - Part-000002
      - Part-000001
  - Assbly-000001
    - Comp-0002
- SL 300 50
  - Assbly-000003
- SL 500
- SL 200 50
- SL 100

Profile Card | Links | Notes | Revision

**User Info**

Created by ...

Creation Date

Modified by ...

Last modification date and time

**Revision Info**

Effective From

Effective Until

Approval Date

Product General | Specifications | Details



- Component general information

Products - Proj-001 System Information: [Profile Card | Links | Notes | Revision]

### Component

Product ID:  State:

Revision:  Phase:

Part Name:

Part Number:

Service Part Number:

Supplier:

Manufacturing Plant:

Product Range:

Comments:

General Info / Specifications / Details / Composition

- Component specifications

Products - Proj-001 System Information: [Profile Card | Links | Notes | Revision]

### Reliability Information

(per Supplier) Type of Parameter:  Reliability figure:

(per Analysis) Type of Parameter:  Reliability Figure:

FMEA Reference: Date of update:

### Costing/Maintenance Information

Price:

Recommended Retail Cost:

Hours to Repair/Replace:   Demonstrated

Scheduled Maintenance Period:

### Standards/Certification

Compliance Certification:

Quality Standards:

General Info / Specifications / Details / Composition

## Dealer Class

- Dealer general information

Dealers - Proj-001 System Information: [ ] [ ] [ ] [ ]

Dealers Tree

- Dealer-0003
- Dealer-0002
- Dealer-0001

Profile Card | Links | Notes

### Dealer

Dealer ID: Dealer-0002

Dealer Name: Figicoll

Address: Avd Gaudi

City: Barcelona Zip:

State: Country: Spain

Phone: xxxxxxxxxxxxxxxx

Fax: xxxxxxxxxxxxxxxx

Mobile Phone: xxxxxxxxxxxxxxxx

Email:

Service Engineer:

Dealership General / Contacts and Details / Creation Modification /

- Dealer contacts and details

Dealers - Proj-001 System Information: [ ] [ ] [ ] [ ]

Dealers Tree

- Dealer-0003
- Dealer-0002
- Dealer-0001

Profile Card | Links | Notes

### Engineering Contact

Name: Jerry Colgan

Position: Workshop supervisor

Phone: xxxxxxxx

Mobile: xxxxxxxxxxxx

Email: xxxxxxxxxxxxxxxx

### Fleet Details

Number of Registered Units: 57 Types: SL 100, 200 and 300

Control Maintenance Percentage: 10

Competitors Units Percentage Competitors: 10

Reliability, Fleet Percentage: 5

Field Testing, Recommended

Comments: Good cooperation in the last year

Dealership General / Contacts and Details / Creation Modification /

## Testing Class

- Testing Request general

The screenshot shows a software window titled "Testing - Proj-001 System Information". On the left is a "Testing Tree" with a tree view containing "Req-000001" and "Rep-000001". The main area is titled "Testing Request" and contains the following fields:

- Test Title: [Empty text box]
- Testing ID: Req-000001
- State: New (dropdown)
- Test Type: Environmental (dropdown)
- Requester: [Empty text box]
- Requested Starting Date: 11/22/2000
- Estimated Duration: 2 months
- Justification: [Empty dropdown]
- Purpose of Test: [Empty text box]
- Product Type: SL 200 50
- Product Range: Trailer-Europe (dropdown)
- Part Number: [Empty text box]
- Part Name: [Empty text box]

At the bottom, there are navigation tabs: "General Info", "Testing Info", and "Details".

- Testing Report general

The screenshot shows the same software window, but now displaying the "Testing Report" form. The "Testing Tree" on the left now includes "Rep-000001" and "Req-000001". The main area is titled "Testing Report" and contains the following fields:

- Test Title: Corrosion Test of Damper Door Motor
- Testing ID: Rep-000001
- State: New (dropdown)
- Request Number: req-999999
- Type of Test: Environmental (dropdown)
- Dates of Testing: Jan, Feb, Mar 00
- Product Range: Trailer-Europe (dropdown)
- Product Type: SL 200 50
- Part Name: Damper Door Motor
- Part Number: 1060512
- Comments: [Empty text box]

At the bottom, there are navigation tabs: "General Info", "Testing Info", "Details", and "Composition".

## Design Class

- Environmental Analysis general

Design - Proj-001 System Information:

Design Tree

- Design-000004 FEA Analysis on tempera
- Design-000003 Environmental Analysis c
- Design-000002 Review of TLE Remote I
- Design-000001 Requirements outlined fo

Profile Card | Links | Notes | Revision | Viewer |

### Environmental Analysis

Design Doc ID: Design-000003

Description: Environmental Analysis of Electric Motor

Product Range: Trailer-Europe

Product Type: SL 200 50

Assembly Component Parts:

Environmental Conditions Type: Corrosion

Other:

Comments:

General / Details

- Design Review general

Design - Proj-001 System Information:

Design Tree

- Design-000004 FEA Analysis on tempera
- Design-000003 Environmental Analysis c
- Design-000002 Review of TLE Remote
- Design-000001 Requirements outlined fo

Profile Card | Links | Notes | Revision | Viewer |

### Design Review

Design Doc ID: Design-000002

Description: Review of TLE Remote Evaporator

Product Range: Trailer-Europe

Product Type: SL 200 50

Assembly Component Parts: 104605, 405861

Review Team: R&D team

Rev Date: 02/01/2000

Comments:

General / Document Details

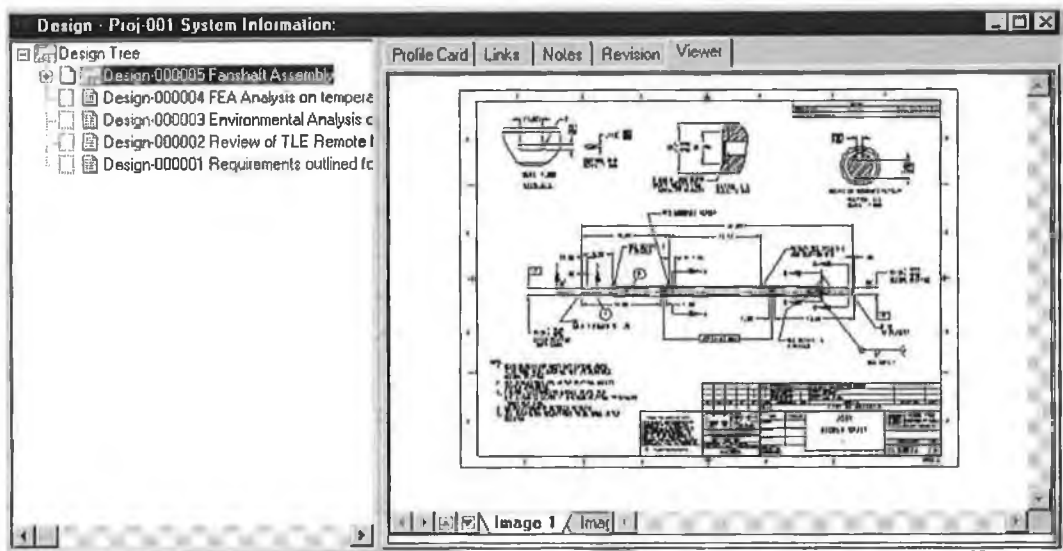

## Reliability Class

- Reliability Specifications general

The screenshot shows a software window titled "Reliability - Proj-001 System Information". On the left is a "Reliability Tree" with the following items:

- Rel-00010 Reliability Specifications
- Rel-00006 Failure Report on Snapp
- Rel-00005 Top-Cost November 00
- Rel-00008
- Rel-00009
- Rel-00002 FMEA on Damper Door b
- Rel-00003 Fault Tree analysis on ele
- Rel-00007
- Rel-00001 Description of reliability is

The main area displays a form titled "Reliability Specifications" with the following fields:

- Reliability ID: Rel-00010
- Phase: [Dropdown]
- Revision: [Text] State: New
- Source: Design Analysis
- Description: Reliability Specifications and Requirements for Electr Mo
- Product Range: Trailer-Europe
- Product Type: [Text]
- Part Number: 1040629
- Part Name: Electric Motor
- Reliability Engineer: Thomas McPhelin
- Comments: [Text Area]

At the bottom of the window, there is a navigation bar with "General" and "Details" tabs.

- Reliability Specifications viewer

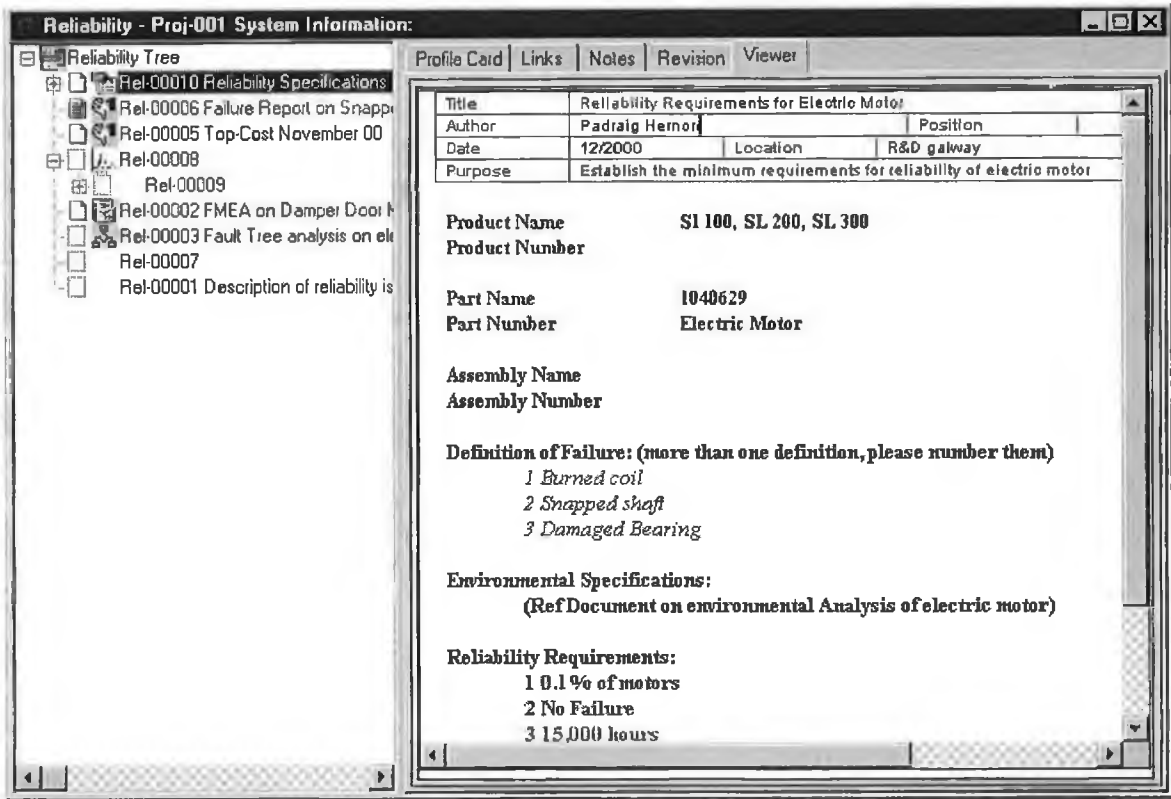

- Fault Tree Analysis General

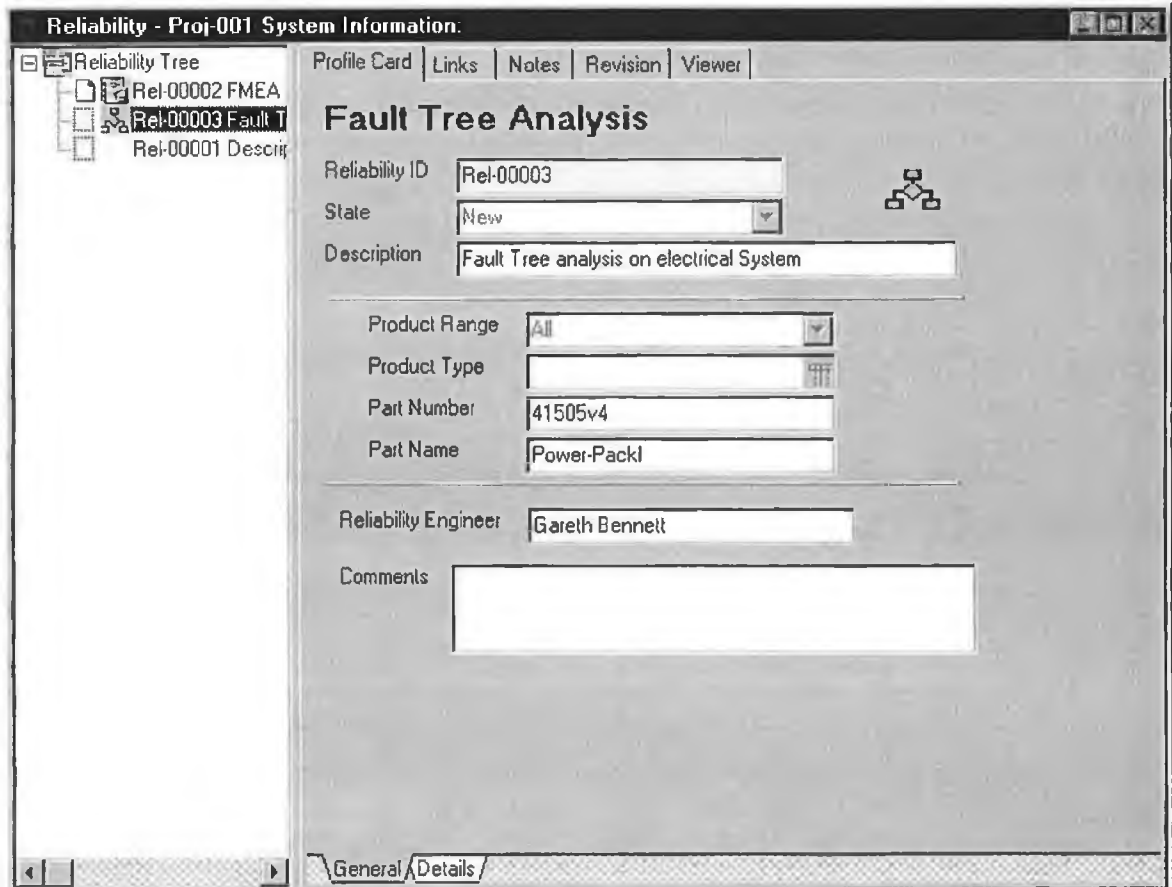

- Fault Tree Analysis viewer

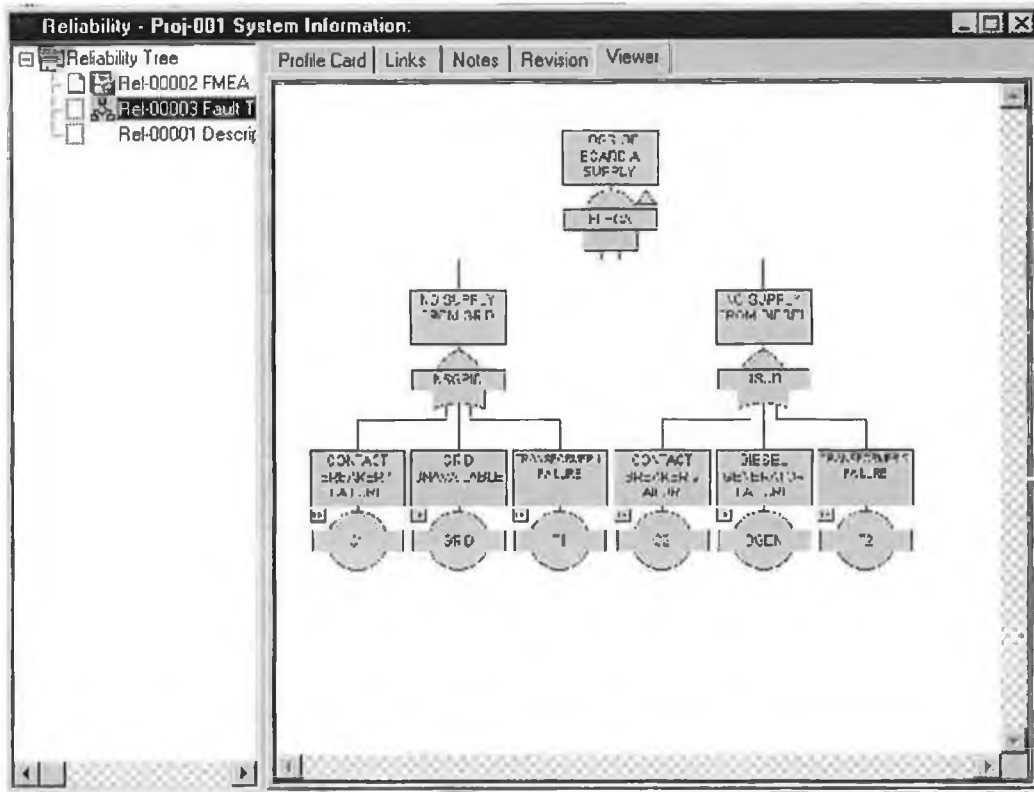

- Life Time Distribution general

Profile Card | Links | Notes | Revision | Viewer

### Life Time Distributions

Distribution ID: Rel-000005 Phase: Prototype

Revision: State: New

Description: Analysis of field failures on belts

Comments:

Analysis on...

Product Type: Product Range: Trailer\_USA

Part/Component/Assembly: Component 3

Failure Mode Analysed: All

Analysis by...

Reliability Engineer: Gareth Bennett

Analysis Results

Distribution Used: Weibull

Summary of Results: R10 life=10,000 hours  
Below expected

General | Doc Details

## Service Class

- Service Bulleting general

The screenshot shows a software window titled "Service - Proj-001 System Information". On the left is a "Service Tree" with folders for "SB-00001" and "CA-000001". The main area is a "Profile Card" for a "Service Bulletin".

Bulletin ID	SB-00001
State	New
Bulletin Title	Refrigerant Recover
Description	
Product Range	Truck
Product Type	SL 200 30
Type of Bulletin	Environmental
Number of Pages	5
Date	
Comments	

At the bottom, there are tabs for "General" and "Details".

## Documents Class

- Letters and Faxes general

The screenshot shows a software window titled "Documentation - Documentation Templates". On the left is a "documentation Tree" with a folder for "Letter/Fax-0000". The main area is a "Profile Card" for "Letters and Faxes".

Letter/Fax ID	Letter/Fax-0000	Phase	Prototype
Revision		State	New
Description of Contents	Update on on-going project		
Comments			
From	Simon Dod	Date Sent	04/04/2000
To	Gareth Bennets	Date Received	11/14/2000
Product Range			
Product Type			

At the bottom, there are tabs for "Letter/Fax Details" and "Doc Details".



- Reference Material

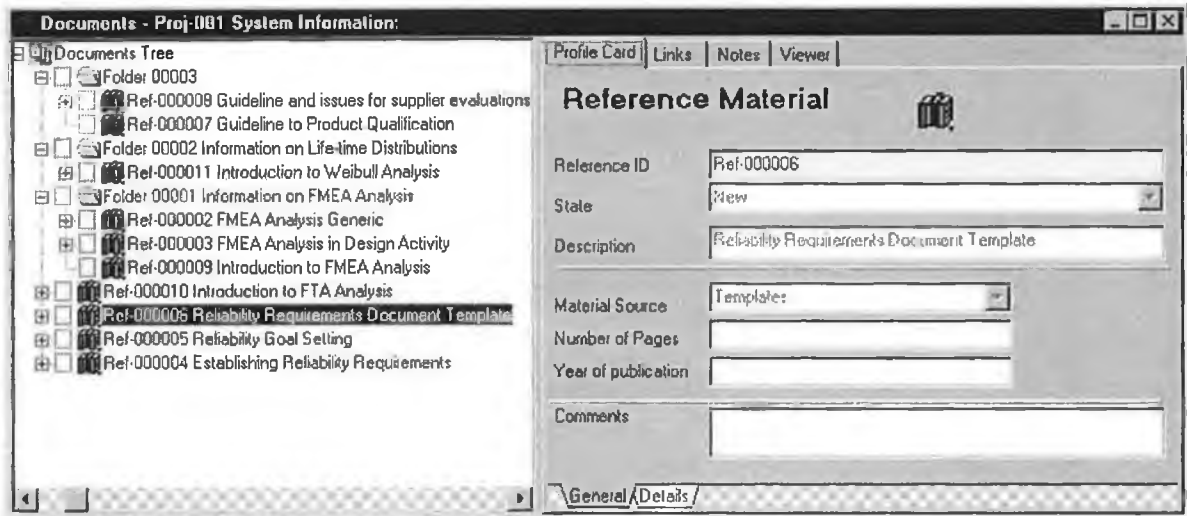

## Users Class

- Users general

